



注重细节 精益求精

PAY ATTENTION TO DETAILS AND KEEP IMPROVING

浙江瑞通阀门有限公司
ZHEJIANG RUITONG VALVE CO.,LTD

地址: 浙江省温州市龙湾区永兴街道空港新区B-16地块
Address: Plot B-16, Airport New Area, Yongxing Street, Longwan District, Wenzhou, Zhejiang

电话Tel: 0577-8588 8060/8061/8062/8063

传真Fax: 0577-8868 8270

网址Web: www.zjrtfm.com



企业官网/WEB

RTV[®] 瑞通阀门
RUITONG VALVE

RUITONG VALVE
MANUFACTURING AND
QUALITY GO HAND IN HAND

瑞通阀门
智造与品质同行



球阀 | 闸阀 | 截止阀 | 止回阀 | 蝶阀 | 过滤器
BALL VALVE, GATE VALVE, GLOBE VALVE, CHECK VALVE, BUTTERFLY VALVE, FILTER

打造具有竞争力的 不锈钢阀门优质制造企业

Building a competitive high-quality manufacturing enterprise for stainless steel valves

CORPORATE
VISION 企业愿景

CONTENTS 目录

企业篇 Enterprise Chapter

001-002	企业简介	Enterprise Introduction
003-004	企业资质	Enterprise Qualification
005-006	生产车间	Production Workshop
007-008	合作伙伴	Cooperative Partner
009	应用领域	Application Area
010	营销网络	Marketing Network

产品篇 Product Section

011	闸阀系列	Gate Valve Series
012	球阀系列	Ball Valve Series
013	截止阀系列	Globe Valve Series
014	止回阀系列	Check Valve Series
015	其他系列	Filter Series
016	蝶阀系列	Butterfly Valve Series
017	锻钢阀门系列	Forged steel valve series
018	丝扣球阀系列	Thread ball valve series

参数篇 Parameter Section

019-023	阀门选型指南	Valve Selection Guide
025-027	美标法兰浮动球阀	API Flange Floating Ball Valve
028	日标球阀	JIS Ball valve
029-030	俄标球阀	API Flange Floating Ball Valve
031-036	Q47F/Y/H型固定式球阀	Q47F/Y/H Fixed Ball Valve
037-040	锻钢球阀	Forged Steel Ball Valve
041-043	国标浮动球阀	GB Floating Ball Valve
045-046	美标闸阀	API Gate Valve
047	日标闸阀	JIS Gate valve
048-049	俄标闸阀	GOST Gate valve
050-053	国标法兰闸阀	GB Flange Gate Valve
055-056	美标截止阀	API Globe Valve
057	日标截止阀	JIS Globe valve
058-059	俄标截止阀	GOST Globe valve
060-063	国标截止阀	GB Globe Valve
065-067	美标旋启式止回阀	API Swing Check Valve
068	日标旋启式止回阀	JIS Swing Check Valve
069-070	俄标旋启式止回阀	GOST Swing Check Valve
071-073	国标旋启式止回阀	GB Swing Check Valve
074-075	国标升降式止回阀	GB Lifting Check Valve
076	国标立式止回阀	GB vertical check valve
078	阀门订货号	Valve Order Number
079	内螺纹与承插焊闸阀	Internal Thread And Socket Welding Gate Valve
080	锻钢法兰闸阀	Forged Steel Flange Gate Valve
081	内螺纹与承插焊截止阀	Internal Thread And Socket Welding Globe Valve
082	法兰与对焊截止阀	Flange And Butt Welded Globe Valve
083	内螺纹与承插焊止回阀	Internal Thread And Socket Welding Check Valve
084	法兰与对焊止回阀	Flange And Butt Welded Check Valve
086-087	不锈钢法兰三通球阀	Stainless Steel Flange Three-way Ball Valve
088-090	全焊接球阀	Fully Welded Ball Valve
091-093	DZ41H/Y/F低温闸阀	DZ41H/Y/F Low-temperature Gate Valve
094	DJ41F-16/40P低温截止阀	DJ41F-16/40P Low-temperature Globe Valve
095	DH41F-40P低温止回阀	DH41F-40P low-temperature Check Valve
097	美标Y型过滤器	API Y-type Filter
098	日标Y型过滤器	JIS Y-type Filter
099	国标Y型过滤器	GB Y-type Filter
100	T型过滤器	T-type Filter
101-109	法兰参数对照表	Flange Parameter Comparison Table
110	材质化学成分表	Material Chemical Composition Table
111-112	售后服务和质量保证承诺	After-sales Service Quality Assurance Commitment

注重细节
精益求精

Pay Attention To Details And
Keep Improving

COMPANY
PROFILE
企业简介

浙江瑞通阀门有限公司 ZHEJIANG RUITONG VALVE CO., LTD



浙江瑞通阀门有限公司坐落于龙湾温州东部，龙湾中心工业区，紧靠温州永强机场，龙湾万吨码头，交通便利。生产、销售于服务一体的阀门制造企业。

Zhejiang Ruitong Valve Co., Ltd. is located in the east of Wenzhou, Longwan Central Industrial Zone, close to Wenzhou Yongqiang Airport and Longwan 10000 ton wharf, with convenient transportation. A valve manufacturer integrating production and sales with service.

主营产品有:闸阀、截止阀、止回阀、球阀、蝶阀、过滤、不锈钢、碳钢阀门。产品可根据不同要求分别采用GB、JIS、API、ANSI、GOST、BS标准进行生产和验收。可根据使用介质、温度不同及材料分别采用碳钢、不锈钢、特殊钢等；广泛应用于化工、石油、轻工、食品、医药、环保等领域。产品出售到各地倍受客商的高度好评。主要产品有：不锈钢闸阀,不锈钢球阀,不锈钢截止阀,不锈钢止回阀,不锈钢蝶阀,不锈钢过滤器,美标闸阀,美标截止阀,美标球阀,美标止回阀,美标过滤器,美标蝶阀,日标闸阀,日标球阀,日标截止阀,日标止回阀,日标蝶阀,日标过滤器,高平台球阀,日标高平台球阀等非标阀门。

Main products include: gate valve, globe valve, check valve, ball valve, butterfly valve, filter, stainless steel, carbon steel valve. GB, JIS, API, ANSI and GOST, BS standards can be used for production and acceptance of products according to different requirements. Carbon steel, stainless steel and special steel can be used according to different media, temperatures and materials; It is widely used in chemical industry, petroleum, light industry, food, medicine, environmental protection and other fields. The products are sold everywhere and highly praised by customers. The main products include: stainless steel gate valve, stainless steel ball valve, stainless steel globe valve, stainless steel check valve, stainless steel butterfly valve, stainless steel filter, American standard gate valve, American standard globe valve, American standard check valve, American standard filter, American standard butterfly valve, Japanese standard gate valve, Japanese standard ball valve, Japanese standard globe valve, Japanese standard check valve, Japanese standard butterfly valve, Japanese standard filter, high platform ball valve, daily elevation platform ball valve and other non-standard valves.

企业推行现代化先进的管理模式，坚持“以质量求生存、以信誉求发展、以科技求创新”的经营理念，诚信务实、敢于超前，是一家专业以出口美标，日标以及德标高端产品为特色。选择瑞通让你放心！打造诚信为本，客户至上”的经营理念，将不断应用新技术、新工艺、新材料，积极开发新品种为广大用户提供优质的阀门产品和更完善的今后服务。

The enterprise pursues a modern and advanced management mode, adheres to the business philosophy of "survival based on quality, development based on reputation, and innovation based on science and technology", and is honest, pragmatic, and dare to lead. It is a professional company characterized by exporting American, Japanese, and German high-end products. You can rest assured by choosing Ruitong! We will continue to apply new technologies, new processes and new materials, and actively develop new varieties to provide our customers with high-quality valve products and better services in the future. We sincerely welcome new and old customers to cooperate with us to create brilliance!

竭诚欢迎新老客户与我们携手合作，共创辉煌！



HONORARY QUALIFICATIONS

荣誉资质

企业荣誉

诚信口碑 匠心打造
多年来
企业秉承“诚信、品质、服务”的经营理念
已顺利通过多项国内及国际认证
并获得多项专利认证
得到社会各界认可
给企业未来发展创造更多机遇!

Enterprise honor

Honesty and reputation, crafted with craftsmanship
these years

The enterprise adheres to the business philosophy of "integrity, quality, and service"
Successfully passed multiple domestic and international certifications
And obtained multiple patent certifications
Recognized by all sectors of society
Create more opportunities for the future development of enterprises!



PRODUCTION WORKSHOP

生产车间

工匠精神

严谨，务实，永不松懈的工作作风
植根于瑞通的每一道生产工序之中
检验员高度负责的心态
溶于每一个部件之中加上最先进的检测设备和严格的科学化管理
使每一个生产的成品经得起客户的精心挑选

Craftsmanship spirit

A rigorous, pragmatic, and never-ending work style
Rooted in every production process of Ruitong
The inspector's highly responsible attitude
Dissolved in every component and equipped with state-of-the-art testing equipment
And strict scientific management
Make every finished product withstand the careful selection of customers



COOPERATION
PARTNER
合作伙伴

瑞通阀门群策群力 竭力服务于各行各业

为了更好地满足客户需求，我们积极进取
勇于开拓，坚持开放与创新
任何先进的工程技术、项目方案和业务管理
只有转化为客户的商业成功才能产生价值
我们坚持客户需求导向，并围绕客户需求持续创新

Ruitong Valve strives to serve various industries through collective planning and efforts
In order to better meet customer needs, we actively strive for progress
Brave to explore, adhere to openness and innovation
Any advanced engineering technology, project solutions, and business management
Only business success that translates into customers can generate value
We adhere to customer demand orientation and continuously innovate around customer needs

ZHEJIANG RUITONG VALVE CO.,LTD

品质
QUALITY

创新
INNOVATIVE

高效
EFFICIENT

共赢
WIN-WIN



中广核集团



军用装备



浙能电力



华电集团



中国核建



新奥燃气



中国石化



中国石油



中海油



1905
延长石油
YANCHANG PETROLEUM



中国化学工程集团



兵器集团



中国神华
CHINA SHENHUA



大唐集团



RTV

APPLICATION AREA 应用领域

应用行业

公司产品被广泛应用于建筑、食品化工、供水系统、医药、船舶、燃气系统等行业，并可根据用户需求开发新型产品

Application industry

The company's products are widely used in industries such as construction, food and chemical industry, water supply system, medicine, shipbuilding, gas system, etc., and new products can be developed according to user needs

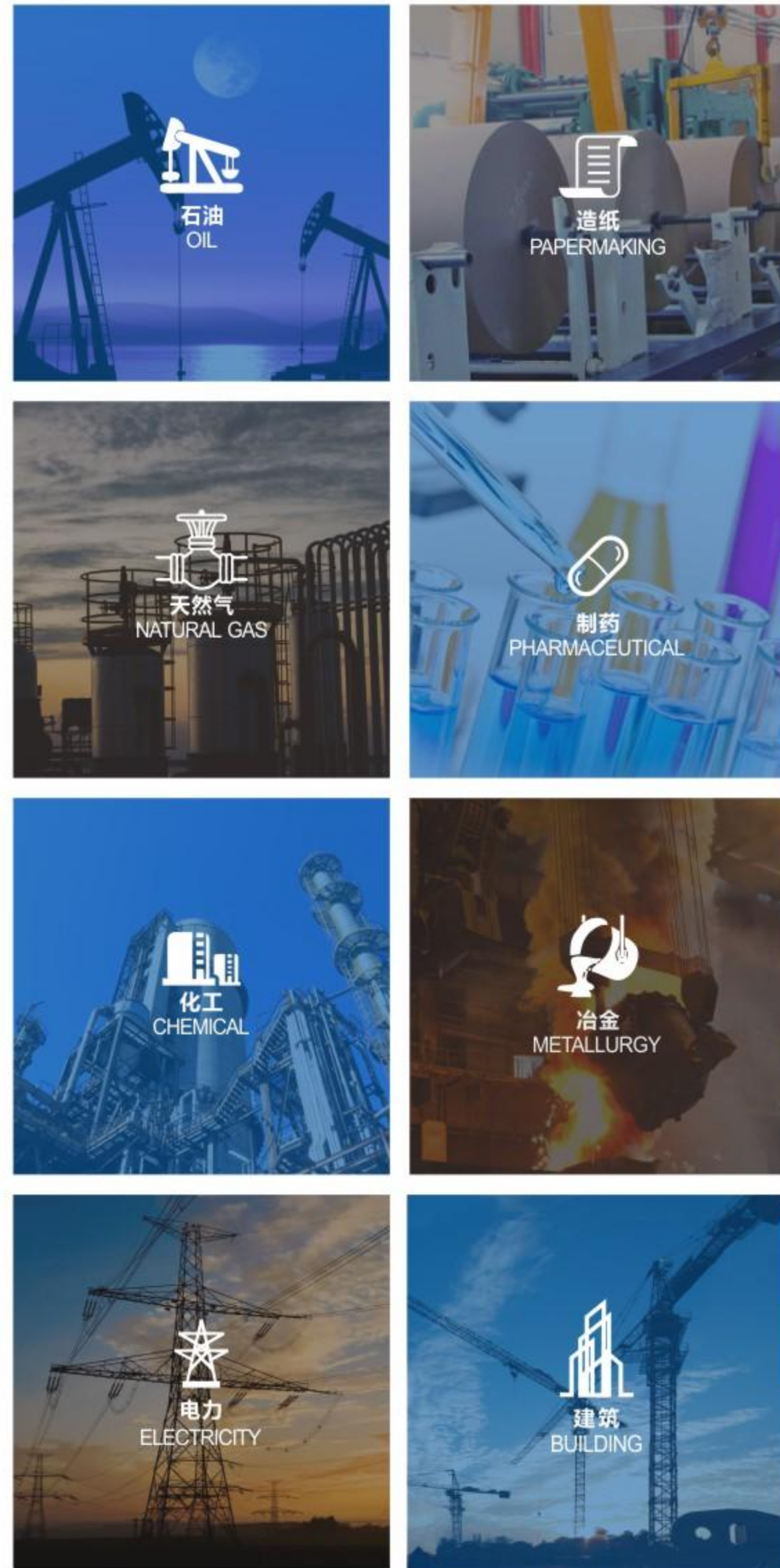

APPLICATION SCENARIO 应用场景

MARKETING NETWORK 营销网络

战略合作

产品远销美国，德国，意大利，新加坡，加拿大，墨西哥，日本，韩国，马来西亚，印度尼西亚，南非，巴西以及中东等国际市场

Strategic cooperation

Our products are exported to the United States, Germany, Italy, Singapore, Canada, Mexico, Japan, South Korea, Malaysia, Indonesia, South Africa, Brazil, And international markets such as the Middle East



GATE VALVE SERIES 闸阀系列



楔式闸阀
Wedge gate valve



俄标法兰闸阀
GOST Gate valve



俄标法兰闸阀
GOST Gate valve



德标法兰闸阀
DIN Gate valve



美标法兰闸阀
Steel gate valve



美标法兰闸阀
Stainless steel Gate valve



美标法兰闸阀
ANSI Gate valve



美标法兰闸阀
WCB API Flange gate valve



美标伞齿轮法兰闸阀
Gear opne gate valve



日标法兰闸阀
JIS Gate valve



SCS13闸阀
SCS13 Gate valve



EN/BS闸阀
EN/BS Gate valve



美标法兰闸阀
150LB Gate valve



国标法兰闸阀
CF8 GB Flange Gate valve



俄标法兰闸阀
321 GOST Gate valve



电动闸阀
Electric gate valve



刀闸阀
Knife Gate valve



API6A闸阀
API6A gate valve

BALL VALVE SERIES 球阀系列



地下球阀
Underground ball valve



气动液压球阀
Pneumohydrodrivate
Ball valve



GOST9544球阀
GOST9544 ball valve



俄标法兰球阀
GOST Stainless steel
Ball valve



美标法兰球阀
API608 Ball valve



美标法兰球阀
ANSI SS Ball valve



美标法兰球阀
150LB Ball valve



美标法兰球阀
API6D Ball valve



日标法兰球阀
SCS13 JIS flanged
Ball valve



日标法兰球阀
WCB JIS Flanged
Ball valve



德标法兰球阀
DIN Ball valve



EN/BS球阀
EN/BS Ball valve



锻钢球阀
Forged steel Ball valve



不锈钢球阀
Stainless steel ball valve



三通法兰球阀
Three way flanged
Ball valve



电动球阀
Electric ball valve



液压球阀
Hydraulic ball valve



气动球阀
Pneumatic ball valve

材质 Material
WCB WCC LCB CF8 CF8M CF3M
WC6 WC9 C5 C11 C12 A105 LF2
F11F22 F55

标准规范 Standard
DESIGN STD:GOST9544 GOST33259
API6D API600 API6A API602 API603
END TO END :ASME 16.10 /GB/T12221
TETING:API598 GB/T13927

连接面及压力 Class
Flange connection method, Welding
connection method
Pressure Class 150# 300# 600# 900#
1500# 2500# Py16 Py25 Py40 Py63
Py100 Py160 Py250

密封内件 Trim NO.
NO.5 NO.8 NO.10 NO.12 NO.12A NO.16

焊接球阀 Welded ball valve
2"-36"•A105/ENP/316 /304• 150#-1500#
Py10-Py100 Dy50-Dy1800
API6D/API608 Py10-Py100

俄标球阀 GOST ball valve
1/2"-8"• WCB/CF8/CF8M/A105
Dy15-Dy600 GOST9544-2015
Py10-Py100

美标球阀 API ball valve
1/2"-8"•WCB/CF8/CF8MA105•150#-600LB
API6D/API608
ASMEB16.

日标球阀 JIS ball valve
15A-400A• SCPH2/SCS13/SUS304/SCS14
•SUS316• 10K-40K
JISB JISB2002 JISB2003

德标球阀 DIN ball valve
DN15-DN200•1.4401/1.4408
DIN3357 DIN2543-2545 DIN3230

GLOBE VALVE SERIES 截止阀系列



截止阀
Globe valve



电磁截止阀
Electromagnetic globe valve



俄标法兰截止阀
GOST Globe valve



BS1873截止阀
BS1873 Globe valve



美标截止阀
ANSI Globe valve



液化天然气截止阀
LNG Globe valve



日标截止阀
JIS Globe valve



电动截止阀
Electric globe valve

材质 Material
WCB WCC LCB CF8 CF8M CF3M
WC6 WC9 C5 C11 C12 A105 LF2
F11F22 F55

标准规范 Standard
DESIGN STD: GOST9544 GOST33259
BS1873 API600 API6A API602 API603
END TO END: ASME 16.10 GB/T12221
TETING: API598 GB/T13927

连接面及压力 Class
Flange connection method, Welding
connection method
Pressure Class 150# 300# 600# 900#
1500# 2500# Py16 Py25 Py40 Py63
Py100 Py160 Py250

密封内件 Trim NO.
NO.5 NO.8 NO.10 NO.12 NO.12A NO.16

CHECK VALVE SERIES 止回阀系列



俄标止回阀
GOST Check valve



俄标止回阀
GOST Check valve



旋转法兰止回阀
Rotary flanged check valve



SS止回阀
SS Check valve



DIN/EN止回阀
DIN /EN Check valve



WCB API法兰止回阀
WCB API Flange check valve



WCB API法兰止回阀
WCB API Flange check valve



SCS13 JIS法兰止回阀
SCS13 JIS Flange check valve

材质 Material
WCB WCC LCB CF8 CF8M CF3M
WC6 WC9 C5 C11 C12 A105 LF2
F11F22 F55

标准规范 Standard
DESIGN STD: GOST9544 GOST33259
BS1868 API600 API6A API602 API603
END TO END: ASME 16.10 GB/T12221
TETING: API598 GB/T13927

连接面及压力 Class
Flange connection method, Welding
connection method
Pressure Class 150# 300# 600# 900#
1500# 2500# Py16 Py25 Py40 Py63
Py100 Py160 Py250

密封内件 Trim NO.
NO.5 NO.8 NO.10 NO.12 NO.12A NO.16

OTHER VALVE SERIES 其他系列



SCS13 JIS过滤器
SCS13 JIS filter



WCB API过滤器
WCB API filter



安全阀
Safety valve



旋塞阀
Plug valve



调节阀
Regulating valve

材质 Material WCB WCC LCB CF8 CF8M CF3M

连接面及压力 Class Flange connection method, Welding connection method, BSPT, BSP, NPT, Pressure Class 150# 300# 600# Py16 Py25 Py40 Py63 Py100 1000WOG 2000WOG

标准规范 Standard DESIGN STD: GOST9544 GOST33259 GB/T 22130 API6D DIN2633 END TO END: ASME 16.10 GB/T12221 TETING: API598 GB/T13927

BUTTERFLY VALVE SERIES 蝶阀系列



法兰蝶阀
Flange butterfly valve
2"-48"•QT450 500 A216-WCB•PN16 150#
GOST AWWAC504 API609 DIN3354 BS5155



钢制蝶阀
Steel butterfly valve
1/2"-8"•QT450/CF8/CF8M•150# PN16 10K
AWWAC504 API609 DIN3354 BS5155



不锈钢蝶阀
Stainless steel butterfly valve
DN50-DN1200•WCB/CF8/SUS304/1.4408
GB/T12238 GOST API609



API/JIS蝶阀
API/JIS butterfly valve
40A-300A•SCPH2/SCS13/SUS304/SCS14
•SUS316•10K-40K
JISB JISB2002 JISB2003
API609



API609蝶阀
API609 butterfly valve
DN15-DN100•1.4408•SUS304•X5GrNiMo1712-2
BS5351 MSS SP-118 DIN3354
ANSI B16.5

材质 Material WCB WCC LCB CF8 CF8M CF3M

连接面及压力 Class Flange connection method, Welding connection method Pressure Class 150# 300# 600# Py10 Py16 Py25 Py40 Py63 Py100

标准规范 Standard DESIGN STD: GOST9544 GOST33259 API609 END TO END: ASME 16.10 GB/T12221 TETING: API598 GB/T13927

FORGED STEEL VALVE SERIES 锻钢阀门系列



锻钢对焊闸阀
Forged steel butt welding gate valve



锻钢低温对焊闸阀 Forged steel low-temperature butt welding gate valve
锻钢低温对焊闸阀 Forged steel low-temperature butt welding gate valve
锻钢自密封承插焊闸阀 Forged steel self sealing socket welding gate valve
锻钢对焊截止阀 Forged steel butt welding globe valve
锻钢自密封对焊截止阀 Forged steel self sealing butt welding globe valve



锻钢Y型截止阀 Forged steel Y-shaped globe valve
锻钢非标闸阀 Forged steel non-standard gate valve
锻钢法兰止回阀 Forged steel flange check valve
锻钢对焊止回阀 Forged steel butt welding check valve
锻钢对焊Y型过滤器 Forged steel butt welding Y-shaped filter



锻钢法兰闸阀 Forged steel flange gate valve
锻钢螺纹闸阀 Forged steel threaded gate valve
锻钢法兰截止阀 Forged steel flange globe valve
锻钢螺纹截止阀 Forged steel threaded globe valve
锻钢法兰球阀 Forged steel flange ball valve

THREAD BALL VALVE SERIES 丝扣球阀系列



一片式丝扣球阀
1PC threaded ball valve



蝶型二片式丝扣球阀 2PC Butterfly threaded ball valve
蝶型内外丝球阀 Butterfly type inner and outer ball valve
德标二片式丝扣球阀 2PC German standard threaded ball valve
二片式丝扣球阀 2PC threaded ball valve
二片式内外丝球阀 2PC inner and outer ball valve



二片式内外丝球阀 2PC inner and outer ball valve
二片式带接管球阀 2PC ball valve with connecting pipe
三片式丝扣球阀 3PC threaded ball valve
三片式对焊球阀 3PC butt welded ball valve
三片式承插焊球阀 3PC socket welding ball valve



三片式内外丝球阀 3PC inner and outer ball valve
真空球阀 Vacuum ball valve
三片式快装球阀 3PC quick installation ball valve
三片式加长杆球阀 3PC extended stem ball valve
三片式焊接球阀 3PC welded ball valve

阀门选型指南 Valve selection guide

编制说明 Manual

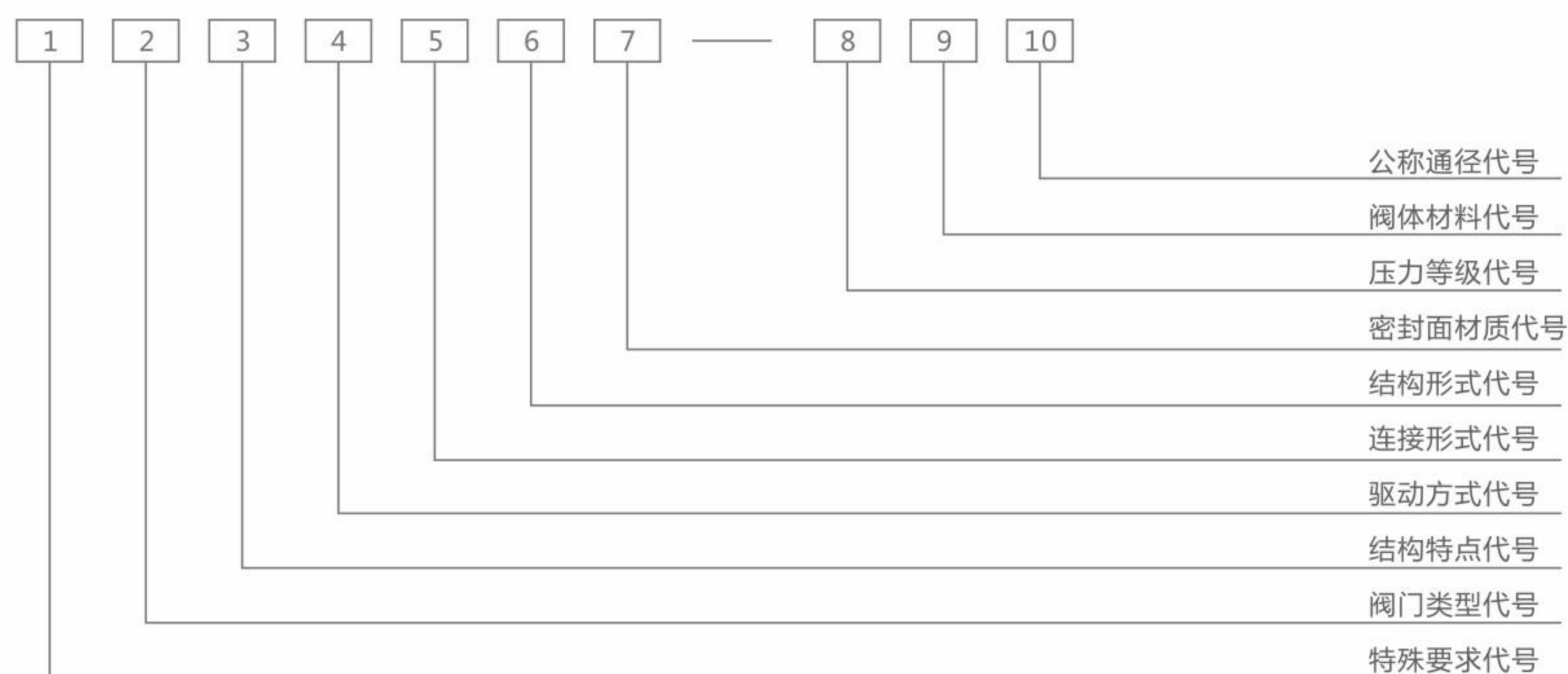

1. 特殊要求代号 Special code

代号	含义	代号	含义	代号	含义
K	抗硫型	L	加长杆型	P	排渣型
D	低温型	B	保温型	LX	两相流型
W	波纹管型	C	带吹扫型	NM	耐磨型
F	防火型	Ds	水封型	HH	缓闭式

注：①抗硫型阀门如无指定内件材料，将按照我公司标准进行内件材料选型；
②低温型阀门需注明最小温度，以便我公司采取适宜的工艺措施；
③加长杆型阀门需执行阀门的加长杆高度。
④带吹扫型需注明是带一个吹扫孔还是两个吹扫孔。一个代号为C1，两个代号为C2。

2. 阀门类型代号 Valve type code

阀门类别	代号	阀门类别	代号	阀门类别	代号	阀门类别	代号
闸阀	Z	一般球阀	Q	节流阀	L	Y型过滤器	YG
水封闸阀	Zs	轨道球阀	Qg	蝶阀	D	篮式过滤器	LG
刀型闸阀	Zd	一体式球阀	Qy	伸缩蝶阀	SD	取样阀	Y
止回阀	H	上装式球阀	Qs	上展示放料阀	Fs	料浆阀	LJ
轴流式止回阀	ZLH	顶装式球阀	Qd	下展示放料阀	Fx	双向承压面旋转阀	SXQ
贯流式止回阀	GLH	全焊接球阀	Qw	柱塞阀	U	抗生素截止阀	JK
蝶式止回阀	HE	V型球阀	Qv	旋塞阀	X	氧气截止阀	Jy
球形止回阀	HQ	截止阀	J	截止止回阀	JH	氧气截止阀	Jh

3. 结构特点代号 (适用于管线球阀, 其他阀门此代号省略) Structural characteristics code

代号	含义	代号	含义
W	体、盖焊接结构	G	体球形 (GWB型) 全焊接管球阀

阀门选型指南 Valve selection guide

4. 驱动方式代号 Driving mode code

代号	阀门类别	代号	阀门类别	代号	阀门类别	代号	阀门类别
3	蜗轮传动	6	气动 (无手动)	6B	气动	9	电动
4	正齿轮传动	6s	气动带手动	7	液动	9B	防暴电动
5	伞齿轮传动	6k	气开	8	气-液动	省略	手动

5. 连接形式代号 Connection form code

代号	连接形式	代号	连接形式	代号	连接形式	代号	连接形式
RF	凸面法兰	M	凸面法兰	T	榫面法兰	BW	对接焊
FM	凹面法兰	RJ	环连接法兰	G	槽面法兰		
1	内螺纹	8	卡箍连接	7	对夹连接		
2	外螺纹	9	卡套	SW	承插焊		

注：法兰和焊接端代号为本公司代号，如需采用国家标准代号，则法兰连接代号为4，焊接端代号为6，订货时需清明为何种形式的法兰和焊接方式。

6. 结构形式代号 Structural code

闸阀 Gate valves

结构形式		代号
明杆	弹性闸阀	0
		1
	刚性	2
		3
暗杆	楔式	4
		5
	平行式	6
		7
	8	

球阀 Ball valve

结构形式		代号
浮动	直通式	1
		2
	三通式	4
		5
固定	直通式	7
	四通	6
	三通式	8
		9

截止阀、节流阀、料浆阀 Globe valve, throttle valve, slurry valve

结构形式	代号	
直通式	1, 2	
角式	3, 4	
Y型	5	
平衡	直通式	6
	角式	7

蝶阀 Butterfly valve

结构形式	代号	结构形式	代号
密封型	中线式	非密封型	中线式
	双偏心		双偏心
	三偏心		三偏心
	连杆机构		连杆机构

止回阀 Check valve

结构形式	代号
升降	直通式
	立式
	角式
旋启	单瓣
	多瓣式
	双瓣式

旋塞阀 Cock

结构形式	代号
填料	直通式
	T型三通式
	四通式
油封	直通式
	T型三通式

阀门选型指南 Valve selection guide

减压阀 Pressure reducing valve

结构形式	代号
薄膜式	1
弹簧薄膜式	2
活塞式	3
波纹管式	4
杠杆式	5

疏水阀 The steam trap

结构形式	代号
浮球式	1
双金属片式	7
脉冲式	8
热动力式	9

7. 密封面材质代号 Sealing surface material code

阀座密封面材料	代号	阀座密封面材料	代号	阀座密封面材料	代号
铁基合金	H	蒙乃尔合金	M	PTFE+碳纤+Cu	FC
聚四氟乙烯	F	巴氏合金	B	PTFE+碳纤	FS
橡胶	X	巴氏合金	A	304	P
内衬橡胶	J	铜合金	T	316	R
硬质合金/司太立合金	Y	对位聚苯PPL	FP	内衬聚四氟乙烯(全衬)	F4
本体直接加工	W	聚醚醚酮PEEK	FP	内衬聚全氟乙烯(全衬)	F46
增强聚四氟乙烯	FR	钼龙	FM	体内衬F4/板CF8	F4/P
高温聚四氟乙烯	FG	尼龙NYLON	N	体内衬F46/板CF8	F46/P

8. 压力等级代号 Pressure rating code : 公称压力以公斤 (bar) 表示, 磅级以实际数

9. 阀体材料代号 Valve body material code

阀体材料	代号	阀体材料	代号	阀体材料	代号
A105	C1	1Cr5Mo	I1	304/0Cr18Ni9	P1
WCB	C2	ZGCr5Mo	I2	Cf8	P2
LCB	C3	F11	I3	1Cr18Ni9Ti	P3
LF1	C4	C5	I4	304/00Cr18Ni10	PI1
LCC	C5	WC5	I5	Cf3	PI2
LF2	C6	WC6	I6	316/00Cr18Ni12Mo2Ti	R1
12CrMoV	V1	15CrMo	I7	CF8M	R2
15CrMoV	V2	TA2	A	316/00Cr17Ni14Mo2Ti	RI1
F22	V3	蒙乃尔合金	M	CF3M	RI2
WC9	V4	可锻铸铁	K	球墨铸铁	Q

注: ①PN≤1.6MPa的灰铸铁阀门, 省略本代号;
②PN≥2.5MPa的碳素钢阀体, 省略本代号;

10. 公称口径代号 Nominal size code : 全口径省略, 缩径的阀门在口径后加S。

阀门选型指南 Valve selection guide

阀门引用标准 Valve reference standard

阀门类型		设计制造	结构长度	连接端	检验试验	壳体壁厚	
闸阀	一般闸阀	GB/ 12234	GB/ T12221	GB/ T 9113 HG 20592 JB/T 79 GB/T 12224	JB/T 9092 GB/T 26480	GB 26640	
	平板闸阀	JB/ 5298 GB/T 23300					
	刀闸阀	JB/ T8691					
闸阀	闸阀/平板闸阀	API 600 API 602 API 6D	ASME B16.10 API 6D	ASME B16.5 ASME B16.47 ASME B16.11 ASME B16.25	API 598 API 6D	ASME B16.34	
	刀闸阀	MSS SP-81 MSS SP-135					
截止阀		国标	GB/T 12235	GB/T 12221	GB/T 9113 HG 20592 JB/T 79 GB/T 12224	JB/T 9092 GB/T 26480	GB 26640
		美标	BS 1873 API 602	ASME B16.10	ASME B16.5 ASME B16.47 ASME B16.11 ASME B16.25	API 598	ASME B16.34
止回阀		国标	GB/T 12236	GB/T 12221	GB/T 9113 HG 20592 JB/T 79 GB/T 12224	JB/T 9092 GB/T 26480	GB 26640
		美标	BS 1868 API 594 API 602 API 6D	ASME B16. 10 API 6D	ASME B16. 5 ASME B16. 47 ASME B16. 11 ASME B16. 25	API 598 API 6D	ASME B16. 34
球阀		国标	GB/T 12237	GB/T 12221	GB/T 9113 HG 20592 JB/T 79 GB/T 12224	JB/T 9092 GB/T 26480	GB 26640
		美标	API 608 API 6D	ASME B16.10 API 6D	ASME B16.5 ASME B16.47 ASME B16.11 ASME B16.25	API 598 API 6D	ASME B16.34
蝶阀		国标	GB/T 12238	GB/T 12221	GB/T 9113 HG 20592 JB/T 79 GB/T 12224	GB/T 13927 GB/T 26480	GB 26640
		美标	API 609	API 609	ASME B16. 5 ASME B16. 47	API 598	ASME B16. 34

阀门选型指南 Valve selection guide

阀门引用标准 Valve reference standard

阀门类型	设计制造	结构长度	连接端	检验试验	壳体壁厚	
旋塞阀	国标	GB/T 22130	GB/T 12221	GB/T 9113 HG 20592 JB/T 79 GB/T 12224	JB/T 9092 GB/T 26480	GB 26640
	美标	API 599 API 6D	ASME B16.10	ASME B16.5 ASME B16.47 ASME B16.11 ASME B16.25	API 598 API 6D	ASME B16.34
疏水阀	GB/T 22654	GB/T 12250	GB/T 9113 HG 20592 JB/T 79 GB/T 12224	GB/T 12251	GB 26640	
隔膜阀	GB/T 12239	GB/T 12221	GB/T 9113 HG 20592 JB/T 79	JB/T 9092	GB 26640	
减压阀	GB/T 12244 GB/T 12246	JB/T 2250	GB/T 9113 HG 20592 JB/T 79	GB/T 12245	GB/T 26640	
电站阀	JB/T 3595	GB/T 12221 ASME B16.10	GB/T 9113 HG 20592 JB/T 79 GB/T 12224 ASME B16.5 ASME B16.25	JB/T 3595	GB/T 26640 ASME B16.34	

性能规范 performance specification

公称压力	PN	Class
	2.5~420	150~2500Lb
壳体(强度)试验	38°C (100F) 时材料压力额定值的 1.5倍	
高压密封试验(水)	38°C (100F) 时材料压力额定值的 1.1倍	
低压密封试验(气)	0.4~0.7MPa	
规格	15~1000	1/2"~40"
适用温度(°C)	-196~550	
适用介质	水、蒸汽、油品、液化气、天然气、硝酸类、醋酸类	



01

RUITONG
VALVE

球阀系列 BALL VALVE SERIES

美标法兰浮动球阀 API Flanged floating ball valve

设计 Design

球阀为提供最大的操作寿命和可靠性而设计和生产的，所有的球阀都符合美国石油学会标准API608和API6D的求和英标BS 5351与美国机械工程师协会标准ASME B16.34一致。阀门由完整的阀体、阀盖和内件组成。

Ball valves are designed and manufactured to provide maximum service life and dependability. All ball valves are full ported and meet the design requirements of API Standard API 608&API 6D, British Standard BS 5351 and generally conform to American Society of Mechanical Engineers Standard ASME B 16.34. Valves are available in a complete range of body/bonnet materials and trims.

材料范围 Rang of Materials

阀体/阀盖的材料包括碳含量的九个等级，低合金和不锈钢，在特殊的适用中，他们可用合金和不锈钢的其他等级。有许多的内件供不同的环境下使用，填料和垫片的选择也为各种环境所具备。

Standard body/bonnet materials include nine grades of carbon, low alloy and stainless steels. For special applications they can be supplied in other grades of alloy and stainless steel. There's a full range of trim materials to match any service. Optional packing and gasket materials are available for a full range of service conditions.

阀门的商标可以按照客户的要求修改 Available Modifications For Trademark Cast Steel Valves

- | | | | |
|------------|--------------------------------|--------------|--|
| * 内件变化 | * Trim changes | * 压力调节 | * Pressure Equalizing |
| * 连接方式改变 | * End connection Modifications | * 静电弹簧/防火标准 | * AS or FD |
| * 填料和垫片的改变 | * Packing and Gasket Changes | * 客户的特殊铸造要求 | * Customer specified Coatings |
| * 固定式操作 | * Operator Mounting | * 焊接端的内孔改变 | * Weld End Bore Changes |
| * 加长手柄 | * Handwheel Extensions | * 氧/氯气的清洁及包装 | * Oxygen & Chlorine Cleaning & Packaging |

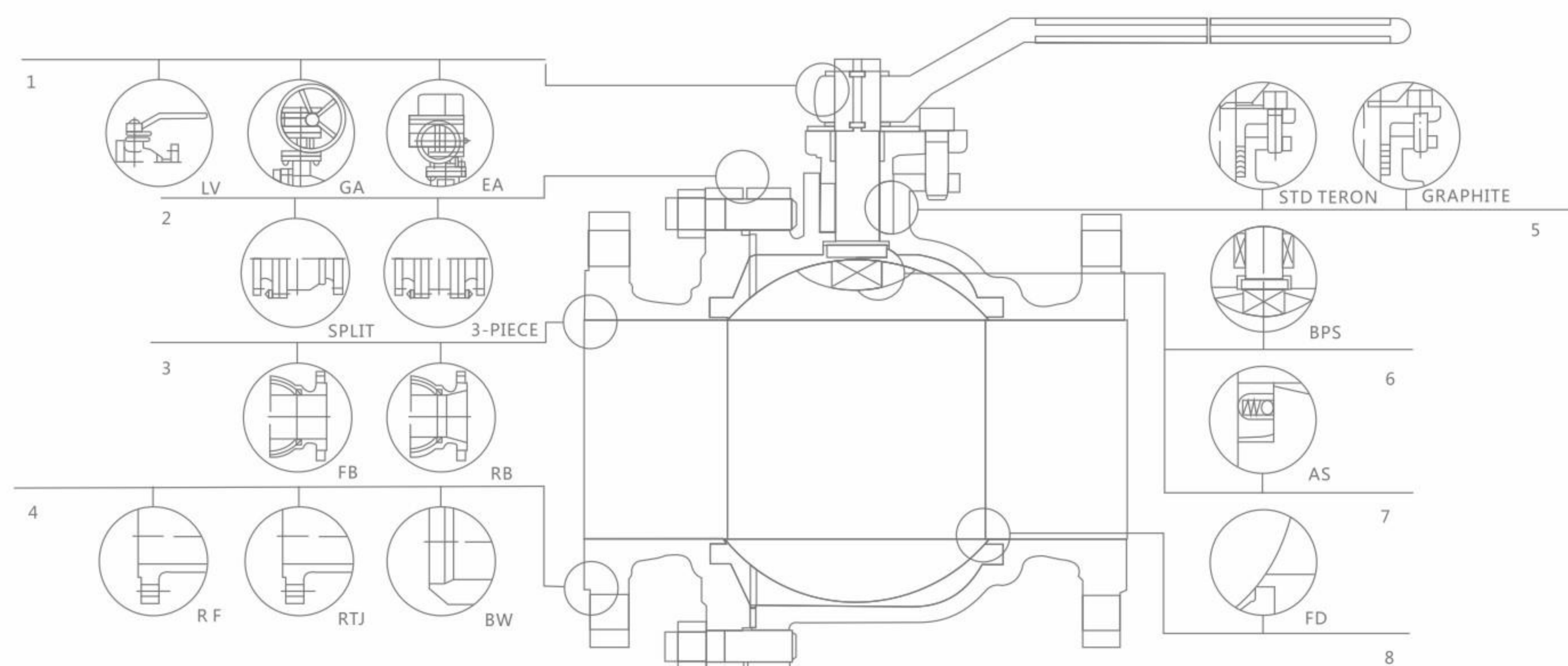

1、操作 Operating

用手柄更容易操作，同样也可以用蜗轮、电动、气动、液动，他们用于更艰难的环境下。Extended lever for easy operation. Also available with gearing, motor actuator, pneumatic or hydraulic actuators for more difficult services.

2、阀体-阀盖 BODY&BONNET

不采3片式12"以下的阀体、阀盖，用这种结构更方便于外部零件的修理和替换。Split or 3-piece split body & bonnet for 12" & Small Disassembles easily for repair or replacement of internal components.

3、通径 BORE

全通径和缩径全通径适用于大的流量介质，也可请扫管路。Full and reduced full diameters are suitable for large flow media, also please sweep the pipe.

4、连接方式 End Connections

可采用法兰连接、环连接、对接焊管件。Flange connection, ring connection and butt welding fitting can be used.

5、填料 Packing

标准填料一般采用特氟龙材质，保证填料在高循环的压缩和严峻的操作环境下，石墨填料适合高温条件下使用。STD Packing Multiple V-TEFLON packing, combined with live loading, maintains packing compression under high-cycle and severe service applications. Graphite packing use situation for high-temperature.

6、阀杆防脱 BPS

防止阀杆脱落，一个压力安全的阀杆设计应该是有防脱结构，在正常压力下不易飞出。To prevent stem shedding, a pressure-safe stem design should be designed with a trip-proof design that does not fly out under normal pressure.

7、静电弹簧 AS

这种连接总是在球体和阀杆/阀体之间运动卸载最终在操作时静止。This connection always moves between the ball and stem/body and the unloading eventually stops during operation.

8、防火标志 FD

根据API607或BS6755来设计，确保他们在发生火灾时的操作适用性，其次金属密封面当主要的密封面被火破坏时就像是一层隔离墙，符合API607的阀门带石墨填料和垫片。Fire Durable. Designed according to API607 or BS6755 to ensure their operability in case of fire, the metal sealing surface ACTS as a barrier when the main sealing surface is damaged by fire, and API607 compliant valves with graphite packing and gaskets.

美标法兰浮动球阀 API Flanged floating ball valve

Q41F-150Lb

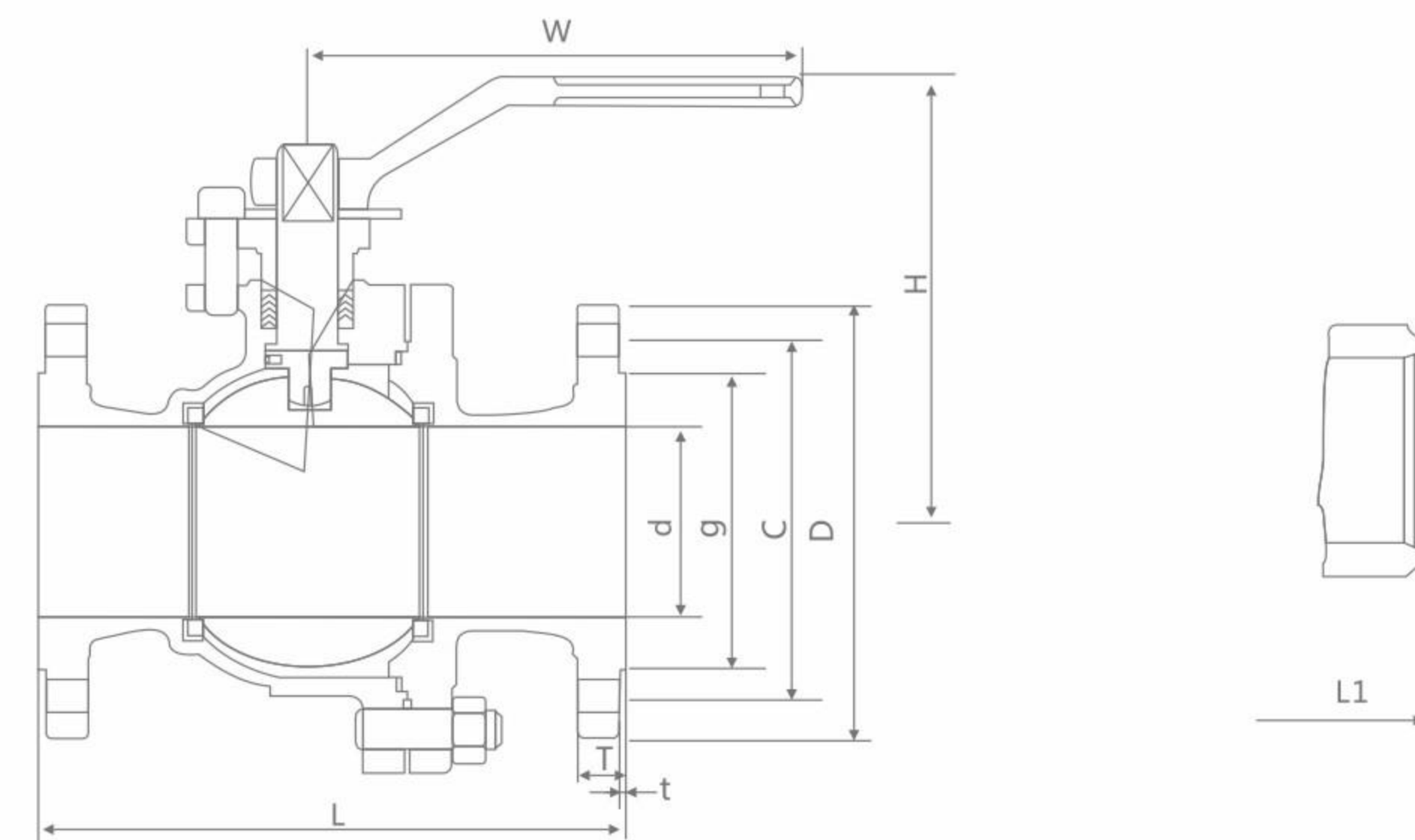

应用标准

球阀符合API 608/API 6D标准
球阀符合ISO 10434/ISO 14313标准
防火标志采用API 607 标准
防静电采用API 608标准
符合ASME B 16.34标准
结构长度符合ASME B 16.10标准
法兰尺寸符合ASME B 16.5标准
对接焊符合ASME B 16.25标准
试验与检验符合API 598/API 6D标准

设计描述

全通径设计
螺栓连接
浮动结构
防脱阀杆
防火设计
静电装置
切断装置
ISO5211 固定盘
法兰/焊接端
蜗轮操作

Applicable standards

BALL VALVES, API 608/API 6D
BALL VALVES, ISO 10434/ISO 14313
FIRE DURABLE, API 607
ANTI STATIC, API 608
VALVES, ASME B 16.34
FACE TO FACE, ASME B 16.10
END FLANGES, ASME B 16.5
BUTTWELDING ENDS, ASME B 16.25
INSPECTION AND TEST, API 598/API 6D

Design description:

FULL PORT DESIGN
BB, BOLTED BONNET, SPLIT BODY
FLOATING BALL TYPE
BLOW-OUT PROOF STEM
FIRE DURABLE CONSTRUCTION
ANTI STATIC DEVICE
STOPPER DEVICE
ISO5211 MOUNTING PAD
FLANGED OR BUTT WELDING ENDS
AVAILABLE WITH BG OPERATOR

各部件材质 Materials of parts

序号 NO	零件名称 Part Name	ASTM材质 ASTM Material		
		碳钢 Carbon Steel	CF8M	CF8
1	阀体 Body	A216-WCB	A351-CF8M	CF8
2	阀盖 Bonnet	A216-WCB	A351-CF8M	CF8
3	球 Ball	A182-F304)	A182-F316	F304
4	阀杆 Stem	A276-304	A276-316	F304
5	阀座 Seat seat		R.PTFE	
6	垫片 Gasket	石墨+3042) Graphite+3042)	PTFE	PTFE
7	阀盖螺栓 Valve cover bolt	A193-B7	A193-B8M	A193-B8M
8	阀盖螺母 Valve cover nut	A194-2H	A194-8M	A194-8M
9	填料 Packing		PTFE	PTFE
10	填料压板 Packing press plate	A216-WCB	CF8	CF8
11	填料螺栓 Packing bolt	A193-B7	A193-B8M	A193-B8M
12	定位片 Positioning sheet	碳钢 Carbon Steel	F304	F304
13	手柄 Handle		碳钢 Carbon Steel	

注释：1、A105+ENP 可选择的 Note:1).A105+ENP optional

2、缠绕石墨垫片 2).Spiral wound construction.

美标法兰浮动球阀 API Flanged floating ball valve

主要连接尺寸 Main connection dimensions

公称压力 Nominal pressure	Size DN	Dimensions(mm)										
		d	L	D	C	g	T	t	H	W	n-Φ	N.m
class 150Lb	1/2"	15	108	89	60.5	35	12.7	1.6	87.5	142	4-15	7
	3/4"	20	117	98	70.0	43	12.7	1.6	87.5	142	4-15	10
	1"	25	127	108	79.5	51	13	1.6	91.5	142	4-15	16
	1 1/4"	32	140	117	89	64	14.5	1.6	107	190	4-15	24
	1 1/2"	40	165	127	98.5	73	15	1.6	128	200	4-15	35
	2"	50	178	152	120.5	92	16	1.6	136	200	4-19	50
	2 1/2"	65	190	178	139.5	105	18	1.6	158	300	4-19	80
	3"	80	203	190	152.5	127	19	1.6	196	350	4-19	120
	4"	100	229	229	190.5	157	24	1.6	212	700	4-19	180
	5"	125	256	254	215.9	186	24	1.6	252	1100	8-22	280
	6"	150	394	279	241.5	261	26	1.6	272	1100	8-22	540
	8"	200	457	343	298.5	270	29	1.6	342	1500	8-22	960
	10"	250	533	406	362	324	30	1.6	345	1500	12-25	1800
	12"	305	610	483	432	381	32	1.6	385	-	12-25	-
	14"	337	686	535	476	413	35	1.6	430	-	12-29	-
	16"	387	762	597	540	470	37	1.6	470	-	16-29	-
18"	489	914	698	635	582	43	1.6	590	-	16-32	-	

主要连接尺寸 Main connection dimensions

公称压力 Nominal pressure	Size DN	Dimensions(mm)										
		d	L	D	C	g	T	t	H	W	n-Φ	N.m
class 300Lb	1/2"	15	140	95	66.5	35	15	1.6	87.5	142	4-15	10
	3/4"	20	152	117	82.5	43	16	1.6	87.5	142	4-15	16
	1"	25	165	124	89.0	51	18	1.6	91.5	142	4-19	25
	1 1/4"	32	178	133	98.5	64	19	1.6	107	190	4-19	35
	1 1/2"	40	190	156	114.5	73	21	1.6	128	200	4-22	50
	2"	50	216	165	127	92	23	1.6	136	200	8-19	70
	2 1/2"	65	241	190	149	105	26	1.6	158	300	8-22	100
	3"	80	283	210	168.5	127	29	1.6	202	350	8-22	160
	4"	100	305	254	200	157	32	1.6	218	700	8-22	280
	5"	125	381	279	235	186	35	1.6	252	1100	8-22	600
	6"	150	403	318	270	216	37	1.6	272	1100	12-22	1000
	8"	200	502	381	330	270	41	1.6	342	1500	12-25	2100
	10"	250	568	444	387.5	324	48	1.6	345	1500	16-29	-
class 600Lb	1/2"	15	165	95	66.5	35	15	6.4	59	160	4-16	17
	3/4"	20	190	117	82.5	43	16	6.4	63	160	4-19	24
	1"	25	216	124	89.0	51	18	6.4	75	230	4-19	40
	1 1/4"	32	229	133	98.5	64	21	6.4	85	300	4-19	60
	1 1/2"	40	241	156	114.5	73	22.3	6.4	95	400	4-22	90
	2"	50	292	165	127	92	25.4	6.4	107	700	8-19	110
	4"	100	432	273	216	157.2	38	6.4	178	1100	8-25	600
	5"	125	491	330	267	186	44.5	6.4	225	1100	8-29	-
	6"	152	559	356	282	216	47.2	6.4	250	1500	12-29	-
8"	203	660	419	349	282	55.7	6.4	294	1500	12-32	-	

日标球阀 JIS ball valve

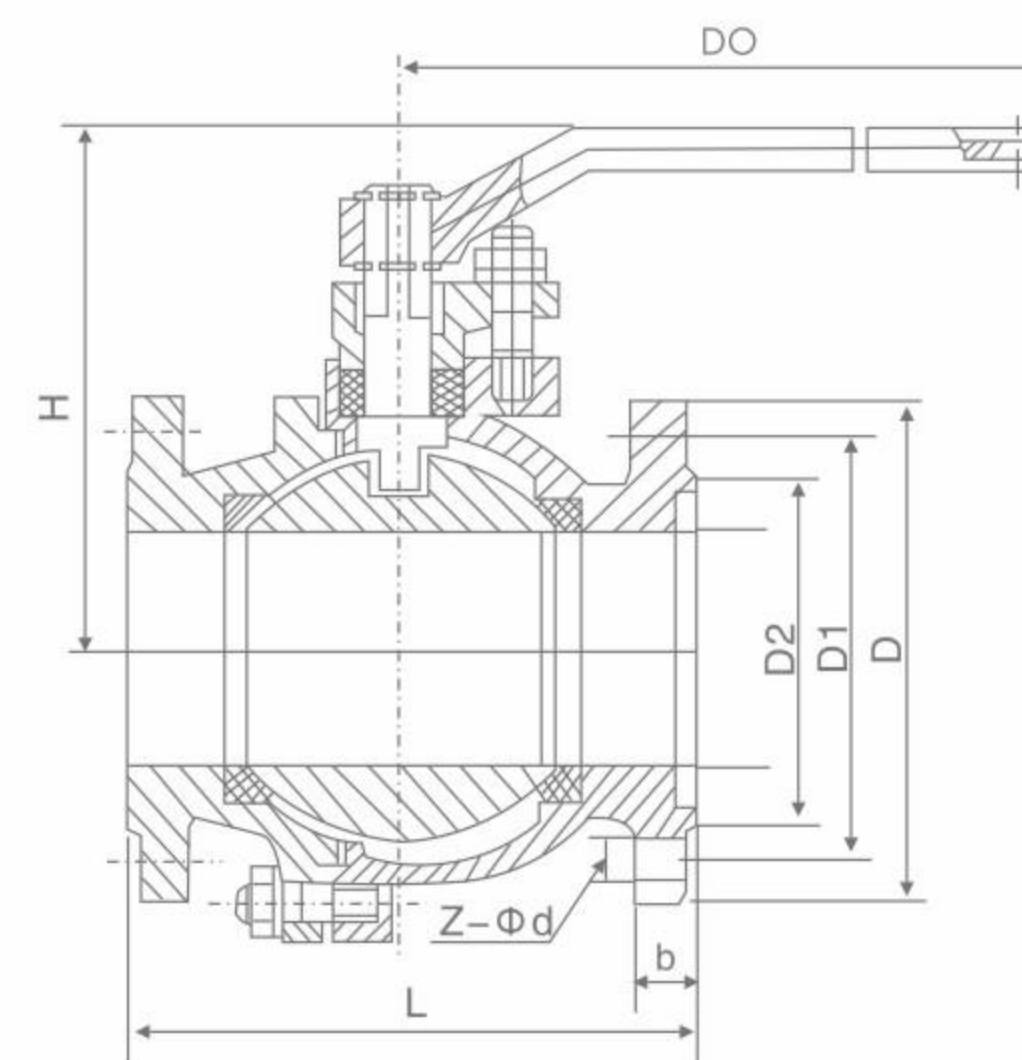

执行标准 Execution standard

设计标准 Design standard	结构长度 Face to Face	法兰连接尺寸 Flange End	压力-温度 Pressure-Temp.	试验与检验 Test & Check
BS 5351	JIS B2002	JIS B2212 B2214	JIS B2201	JIS B2003

规格主要尺寸 Main size

DN		10K							
mm	in	L	D	D1	D2	B	Z-Φd	H	DO
15	1/2"	108	95	70	52	12	4-Φ15	59	130
20	3/4"	117	100	75	58	14	4-Φ15	63	130
25	1"	127	125	90	70	14	4-Φ19	75	160
32	1 1/4"	140	135	100	80	16	4-Φ19	75	160
40	1 1/2"	165	140	105	85	16	4-Φ19	95	230
50	2"	178	155	120	100	16	4-Φ19	107	230
65	2 1/2"	190	175	140	120	18	4-Φ19	142	400
80	3"	203	185	150	130	18	8-Φ19	152	400
100	4"	229	210	175	155	18	8-Φ19	178	700
125	5"	356	250	210	185	20	8-Φ23	252	1100
150	6"	394	280	240	215	22	8-Φ23	272	1100
200	8"	457	330	290	265	22	12-Φ23	342	1500
20K									
15	1/2"	140	95	70	52	14	4-Φ15	59	130
20	3/4"	152	100	75	58	16	4-Φ15	63	130
25	1"	165	125	90	70	16	4-Φ19	75	160
32	1 1/4"	178	135	100	80	18	4-Φ19	75	160
40	1 1/2"	190.5	140	105	85	18	4-Φ19	95	230
50	2"	216	155	120	100	18	8-Φ19	107	230
65	2 1/2"	241	175	140	120	20	8-Φ19	142	400
80	3"	283	200	160	135	22	8-Φ22	152	400
100	4"	305	225	185	160	24	8-Φ22	178	700
125	5"	381	270	225	195	26	8-Φ22	252	1100
150	6"	403	305	260	230	28	12-Φ22	272	1100
200	8"	502	350	305	275	30	12-Φ25	342	1500

俄标球阀
GOST ball valve

GOST 33259

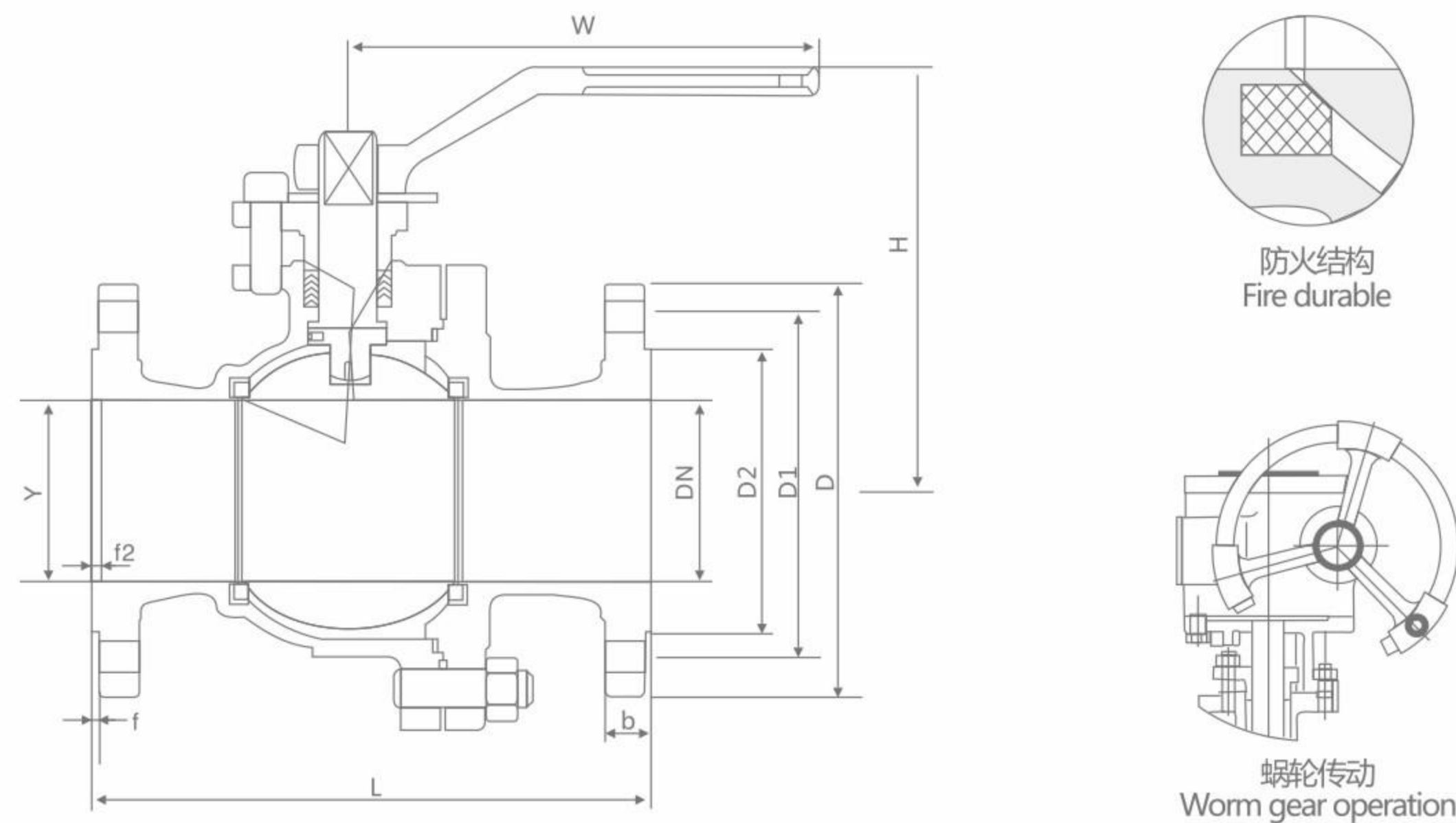

主要外形和连接尺寸 Main external and connection dimension

单位Unit:mm

公称通径 DN	主要外形和连接尺寸 Main external and connection dimensions									N.m	WT (kg)
	L	D	D1	D2	b	f	Z-Φd	H	W		
PN16											
15	130	95	65	45	16	2	4-Φ14	78	140	6	3
20	140/130	105	75	55	18	2	4-Φ14	84	160	9	4
25	150/140	115	85	65	18	2	4-Φ14	95	180	14	5
32	165	140	100	78	18	2	4-Φ18	150	250	22	9
40	180/165	150	110	85	18	2	4-Φ18	150	300	32	11
50	200/203	165	125	100	18	2	4-Φ18	170	350	40	15
65	220/222	185	145	120	18	2	8-Φ18	195	350	60	19
80	250/241	200	160	135	20	2	8-Φ18	215	400	90	27
100	280/305	220	180	155	20	2	8-Φ18	250	500	130	38
125	320/356	250	210	185	22	3	8-Φ18	265	600	250	58
150	360/394	285	240	210	22	3	8-Φ22	270	800	490	81
200	400/457	340	295	265	24	3	12-Φ22	330	800	860	95
250	533	405	355	320	26	3	12-Φ26	450	1300	-	140

俄标球阀
GOST ball valve

GOST 33259

主要外形和连接尺寸 Main external and connection dimension

单位Unit:mm

公称通径 DN	主要外形和连接尺寸 Main external and connection dimensions										N.m	WT (kg)
	L	D	D1	D2	b	Y	f2	Z-Φd	H	W		
PN25												
15	130	95	65	45	16	-	-	4-Φ14	103	100	8	3
20	140	105	75	55	18	-	-	4-Φ14	112	160	12	4
25	150	115	85	65	18	-	-	4-Φ14	123	160	18	6
32	165	140	100	78	18	-	-	4-Φ18	150	250	28	10
40	180	150	110	85	18	-	-	4-Φ18	156	250	40	14
50	200	165	125	100	20	-	-	4-Φ18	172	350	55	20
65	220	185	145	120	22	-	-	8-Φ18	197	350	85	25
80	250	200	160	135	24	-	-	8-Φ18	222	450	130	30
100	280	235	190	160	24	-	-	8-Φ22	253	450	190	40
125	320	270	220	188	26	-	-	8-Φ26	275	600	320	65
150	360	300	250	218	28	-	-	8-Φ26	286	800	620	85
200	400	360	310	278	30	-	-	12-Φ26	340	1200	1100	100
250	533	425	370	332	32	-	-	12-Φ30	470	1400	-	165
PN40												
15	130	95	65	45	16	40	4	4-Φ14	103	100	10	3
20	140	105	75	55	18	51	4	4-Φ14	112	160	15	4
25	150	115	85	65	18	58	4	4-Φ14	123	160	23	6
32	180	140	100	78	18	66	4	4-Φ18	150	250	32	10
40	200	150	110	85	18	76	4	4-Φ18	156	250	45	14
50	220	165	125	100	20	88	4	4-Φ18	172	350	65	20
65	250	185	145	120	22	110	4	8-Φ18	197	350	95	25
80	280	200	160	135	24	121	4	8-Φ18	222	450	150	30
100	320	235	190	160	24	150	4.5	8-Φ22	253	450	260	40
125	400	270	220	188	26	176	4.5	8-Φ26	275	600	550	65
150	400	300	250	218	28	204	4.5	8-Φ26	286	800	900	85
200	550	375	320	282	34	260	4.5	12-Φ30	340	1200	1800	100
250	568	450	385	345	38	313	4.5	12-Φ33	470	1400	-	165
PN63												
15	140	105	75	55	20	40	4	4-Φ14	105	130	15	3.1
20	155	130	90	68	22	51	4	4-Φ18	125	130	20	4.9
25	180	140	100	78	24	58	4	4-Φ18	135	160	35	7.2
32	200	155	110	82	26	66	4	4-Φ22	150	160	50	8.7
40	220	170	125	95	28	76	4	4-Φ22	165	230	70	12.1
50	250	180	135	105	26	88	4	4-Φ22	175	230	85	16.7
65	280	205	160	130	26	110	4	8-Φ22	200	400	130	28.2
80	320	215	170	140	28	121	4	8-Φ22	210	400	200	36
100	350	250	200	168	30	150	4.5	8-Φ26	250	700	340	66
125	455	295	240	202	34	176	4.5	8-Φ30	295	1100	-	98
150	495	345	280	240	36	204	4.5	8-Φ33	340	1500	-	142

Q47F/Y/H型固定式球阀 Fixed ball valve

结构特点及用途 Structural characteristics and uses

1、操作省力：球体由上下轴承支撑，减少摩擦，消除了由于进口压力推动球体与密封座形成的巨大密封负荷而造成过大的扭矩。

1、 Operation: ball bearings supported by the up and down, to reduce friction, eliminate the pressure as imports to promote the formation of the sphere and the great seal sealed seat load caused by excessive torque.

2、密封性能可靠（见图1）：PTFE弹性材料密封圈嵌于不锈钢阀座内，金属阀座尾端没有弹簧，保证密封圈足够的预紧力，阀门在使用过程中密封面摩擦损时，在弹簧作用下阀门继续保证良好密封性能。

2、 Sealing performance and reliable (see Figure 1): PTFE elastic material embedded in stainless steel valve seat ring, the metal spring seat no end, to ensure adequate preload ring, valve sealing surface in the course of friction loss When the valve under the action of the spring to ensure good sealing performance.

3、防火结构（见图2）：为防止由于骤热或火灾的出现，使聚四氟乙烯密封圈烧毁，发生较大泄漏，而助长火势，在球体与阀座间设置防火密封环，在密封圈烧毁时，在弹簧力作用下，将阀座密封环迅速推向球体上，形成金属与金属密封，起到一定程度的密封效果。耐火试验符合API 6FA和API 607标准要求。

3、 Fire structure (see Figure 2): In order to prevent the sudden appearance of heat or fire to burn PTFE seals, large leak occurred, and contribute to the fire, the fire ball and set the seal ring between the valve seat, in the ring when burned, under the action of the spring force will quickly push the ball valve seat seal ring, the formation of metal to metal seal, play a certain degree of sealing effect. The fireproof experiment conforms to API 6FA and the API 607 standard requests.

4、自动泄压功能（见图3）：当阀门中腔停滞的介质压力异常升高超过弹簧的预紧力时，阀座后退脱离球体，达到自动泄压的效果，卸压后阀座自动复位。

4、 Automatic pressure relief function (see Figure 3): When the valve is in a stagnant medium pressure in the cavity increased over the spring preload, the seat back from the ball, to the effect of automatic pressure relief, pressure relief valve seat after automatically reset.

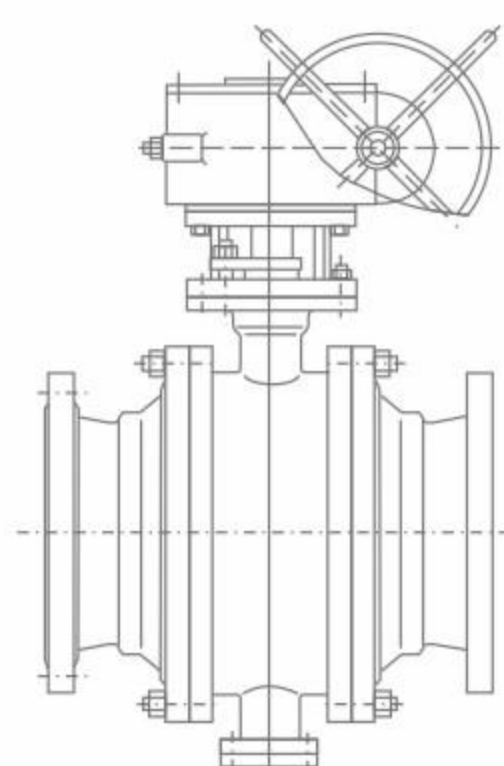

图一 Figure 1

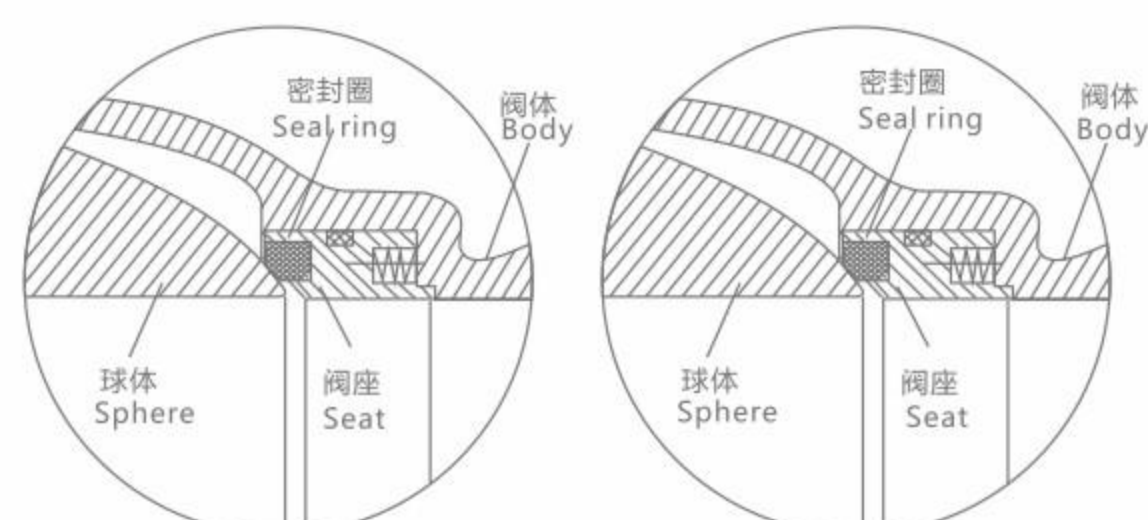

平常时的密封 Usual seals when
软密封烧损时的密封 Burning of soft seal when the seal

图二 Figure 2

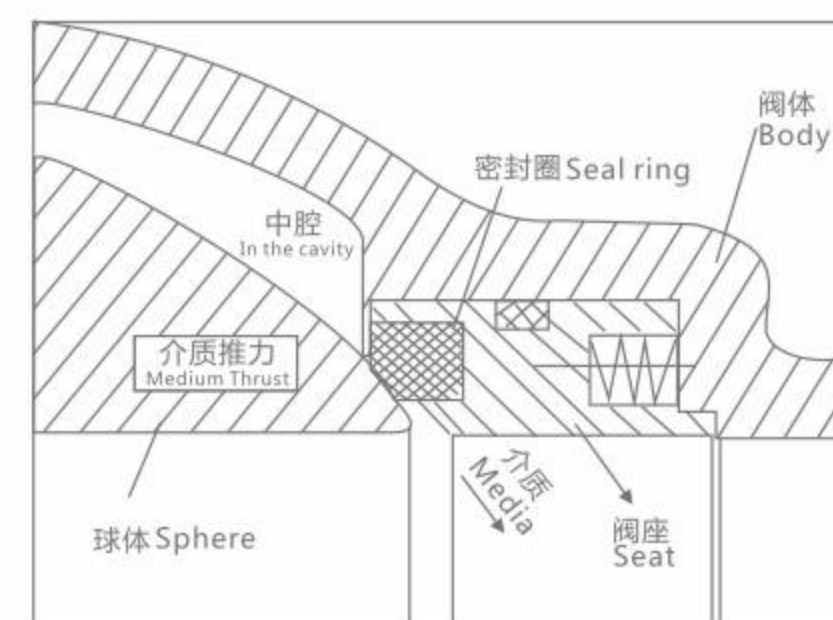

自动卸压功能
Automatic pressure relief feature

图三 Figure 3

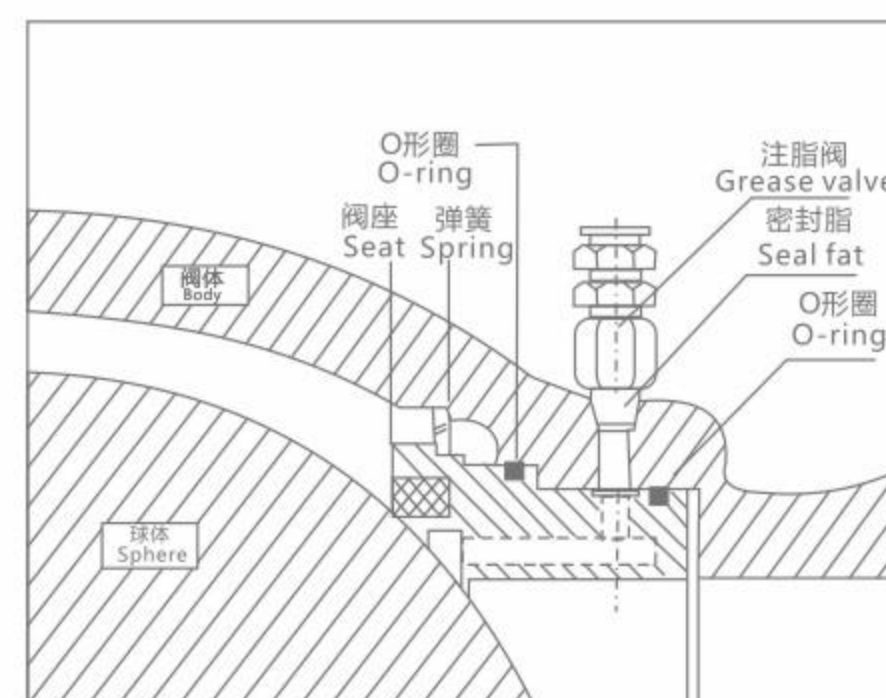

图四 Figure 4

Q47F/Y/H型固定式球阀 Fixed ball valve

5、排泄管路：阀体上下均设置排泄孔，可检查阀座是否发生泄漏，在工作中，阀门处于全开或全关时，卸掉中腔压力，可直接更换填料；可以排放中腔滞留物，减少介质对阀门的污染。

辅助密封设置系统（客户需要请在订购时说明）

5、 Discharge tube: the upper and lower body were set to vent, to check whether the leak valve seat, at work, the valve is fully open or fully closed, the removal of the pressure in the cavity can directly replace the packing; to emissions cavity left in reducing pollution of medium on the valve.

Auxiliary sealing set the system (customer needs when ordering please specify)

6、见图4：本阀门设计有辅助的阀座紧急密封系统，一旦密封受损或出现紧急情况而不能密封时，通过辅助密封系统向密封面注射相应的密封剂即可修复密封面，达到紧急密封。当输送的介质不洁或含有少量颗粒时，为保护密封面，确保达到可靠的密封，还可给这一装置注射相应的清洗剂或润滑剂对密封面进行清洗。

6、 Figure 4: The auxiliary valve seat designed for emergency sealing system, once the seal damage or emergency situations cannot be sealed, through the auxiliary sealing system corresponding to the sealing surface sealant injection sealing surface can be repaired, to an emergency seal. When the transport medium or containing a small amount of contaminated particles, in order to protect the sealing surface and ensure that a reliable seal, the device can also be injected to the appropriate cleaning agents or lubricants on the sealing surface cleaning.

7、广泛适用于食品、医药、石油、化工、天然气、钢铁、环保、造纸等输送管路介质的切断或流通。还可给这一装置注射相应的清洗剂或润滑剂对密封面进行清洗。

7、 Widely used in food, medicine, petroleum, chemical, natural gas, steel, environmental protection, paper and other media to cut off pipeline transportation or circulation. The device can also be injected to the appropriate cleaning agents or lubricants on the sealing surface cleaning.

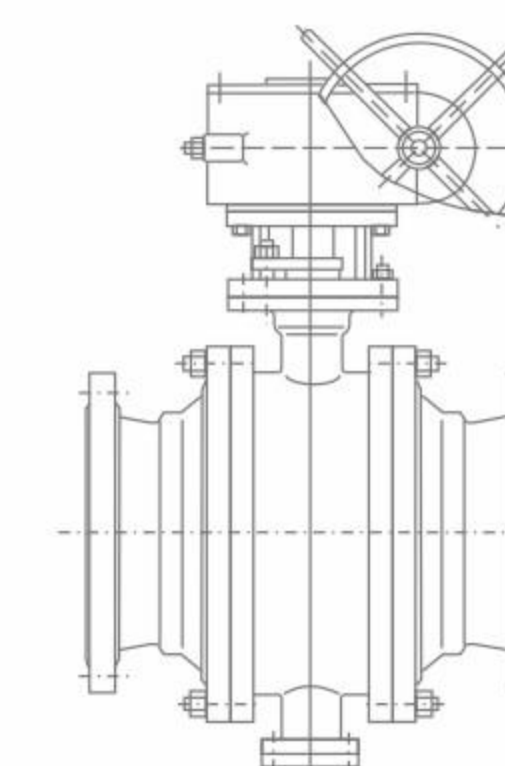

图一 Figure 1

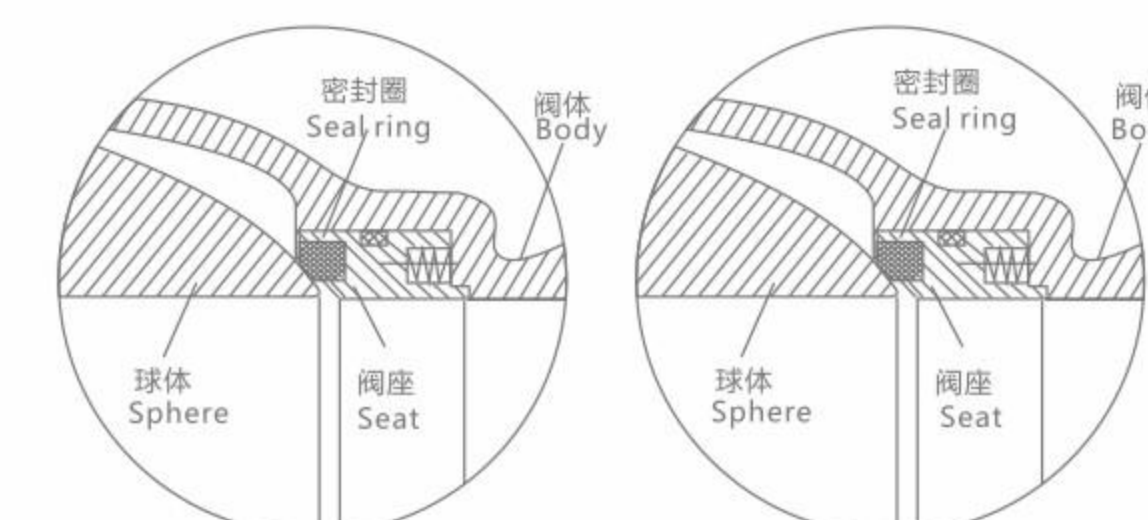

平常时的密封 Usual seals when
软密封烧损时的密封 Burning of soft seal when the seal

图二 Figure 2

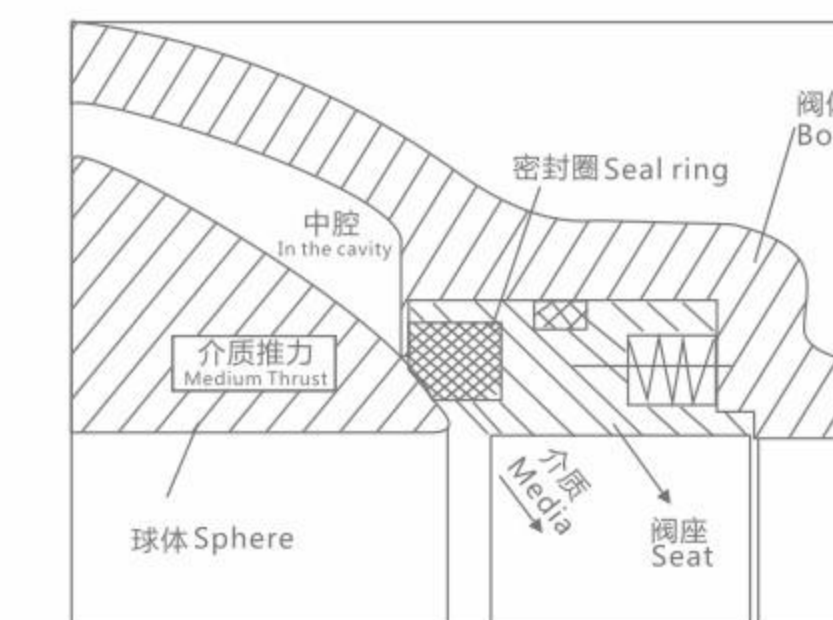

自动卸压功能
Automatic pressure relief feature

图三 Figure 3

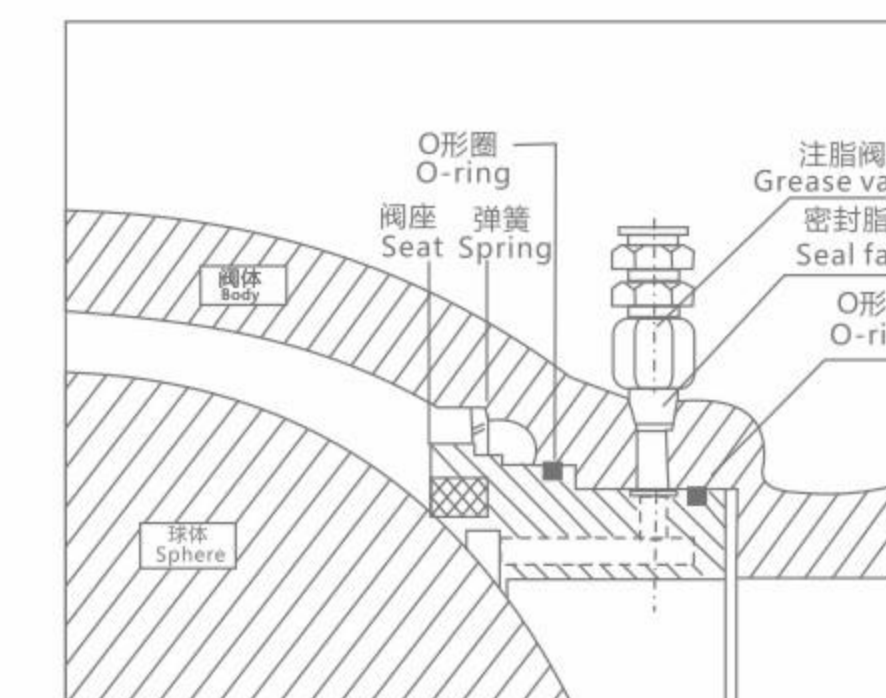

图四 Figure 4

Q47F/Y/H型固定式球阀

Fixed ball valve

执行标准 Implementation of standards

- 1、设计和制造 Design and manufacture : GB/T 12237;API 608
- 2、检验和试验 Inspection and test : GB/T 26480-2011;API 598
- 3、法兰连接 Flange connection : HG/T 20592-2009;ASME/ANSI B 16.5
- 4、结构长度 Structure length : GB/T 12221-2005;ASME/ANSI B 16.10

性能规范 Performance Specifications

试验压力 Test pressure 单位 Unit : MPa

公称压力 PN	常温最大工作压力 Max temperature Working pressure	壳体试验压力 Case Test pressure	气密封试验压力 Gas Seals test pressure	高压密封试验压力 High-pressure sealing test pressure
1.6	1.6	2.4	0.6	1.76
2.5	2.5	3.8	0.6	2.75
4.0	4.0	6.0	0.6	4.4
6.4	6.4	9.6	0.6	7.1
Class 150	2.0	3.0	0.6	2.2
Class 300	5.0	7.5	0.6	5.5

使用范围 Terms of Use

壳体材料 Shell material	阀座材料 Seat material	适用温度 Applicable temperature	适用介质 Applicable media
碳钢C型 Carbon Steel C	聚四氟乙烯PTFE	≤150°C	水、蒸汽、油品等 Water, steam, oil, etc.
	对位聚苯 Counterpoint polystyrene	≤250°C	
铬镍钛钢P型 Chrome P-type nickel-titanium steel	聚四氟乙烯PTFE	≤150°C	硝酸类Nitric acid
	对位聚苯 Counterpoint polystyrene	≤200°C	
铬镍钼钛钢R型 Chrome-nickel steel R-Mo Ti	聚四氟乙烯PTFE	≤150°C	醋酸类Acetic acid
	对位聚苯 Counterpoint polystyrene	≤200°C	

主要零件材料 Main components material

阀体、阀盖 Body, bonnet	GB	WCB	ZG0Cr18Ni9	ZG0Cr17Ni12Mo2
	ASTM	WCB	CF8	CF8M
球体 Ball body	GB	2Cr13	0Cr18Ni9	0Cr17Ni12Mo2
	ASTM	420	304	316
阀杆 Stem	GB	2Cr13	0Cr18Ni9	1Cr18Ni12Mo2Ti
	ASTM	420	304	316
阀座 Seat	GB	2Cr13/PTFE	0Cr18Ni9/PTFE	0Cr17Ni12Mo2/PTFE
	ASTM	420/PTFE	304/PTFE	316/PTFE
填料 Packing	GB	PTFE	PTFE	PTFE
	ASTM	PTFE	PTFE	PTFE
螺栓 Bolt	GB	35	0Cr18Ni9	0Cr18Ni9
	ASTM	A193 B7	A320-B8	A320-B8
螺母 Nut	GB	45	0Cr18Ni9	0Cr18Ni9
	ASTM	A194 2H	A190-8	A194-8

Q47F/Y/H型固定金属密封球阀

Fixed metal seal ball valve

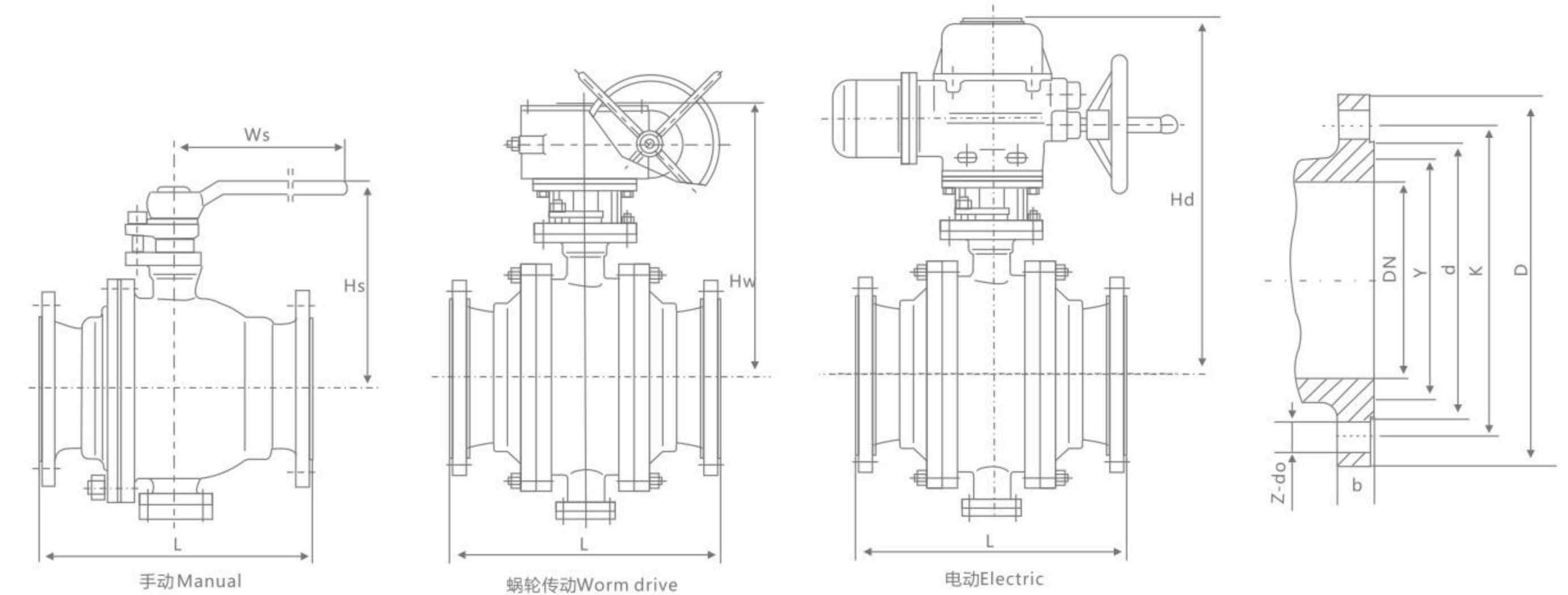

主要连接尺寸 Main connection dimensions

HG/T 20592

公称压力 PN	公称口径 DN	尺寸 Size (mm)											
		L	D	K	d	Y	b	Z-do	Ws	Hs	Hw	Hd	N.m
1.6MPa	150	394	285	240	210	-	22	8-23	1000	305	470	540	300
	200	457	340	295	265	-	24	12-23	-	-	520	580	450
	250	533	405	355	320	-	26	12-25	-	-	610	640	750
	300	610	460	410	375	-	28	12-25	-	-	650	690	1250
	350	686	520	470	435	-	32	16-25	-	-	740	785	2000
	400	762	580	525	485	-	36	16-30	-	-	795	830	2350
	450	864	640	585	545	-	38	20-30	-	-	860	910	3300
	500	914	705	650	608	-	42	20-34	-	-	945	990	4300
	600	1067	840	770	718	-	46	20-41	-	-	1040	1090	7400
	700	1245	910	840	788	-	48	24-41	-	-	1150	1210	-
	800	1372	1020	950	898	-	50	24-41	-	-	1280	1340	-
	900	1524	1120	1050	998	-	52	28-41	-	-	1430	1510	-
	1000	1753	1255	1170	1110	-	54	28-48	-	-	1580	1640	-
	1200	2032	1485	1390	1325	-	56	32-54	-	-	1810	1910	-
1400	2300	1685	1590	1525	-	60	36-54	-	-	2010	2115	-	
2.5MPa	150	403	300	250	218	-	30	8-25	1000	305	470	555	380
	200	502	360	310	278	-	34	12-25	-	-	540	595	630
	250	568	425	370	332	-	36	12-30	-	-	630	655	1050
	300	648	485	430	390	-	40	16-30	-	-	650	705	1750
	350	762	550	490	448	-	44	16-34	-	-	740	795	2600
	400	838	610	550	505	-	48	16-34	-	-	795	830	3200
	450	914	660	600	555	-	50	20-34	-	-	860	910	4600
	500	991	730	660	610	-	52	20-41	-	-	945	990	6000
	600	1143	840	770	718	-	56	20-41	-	-	1040	1090	10000
	700	1346	955	875	815	-	60	24-48	-	-	1150	1210	-
	800	1524	1070	990	930	-	64	24-48	-	-	1305	1340	-
	900	1727	1180	1090	1025	-	66	28-54	-	-	1505	1600	-
	1000	1880	1305	1210	1140	-	68	28-58	-	-	1615	1705	-
	1200	2184	1525	1420	1350	-	72	32-58	-	-	1925	2035	-
1400	2300	1750	1640	1560	-	78	36-65	-	-	2110	2185	-	

Q47F/Y/H型固定金属密封球阀

Fixed metal seal ball valve

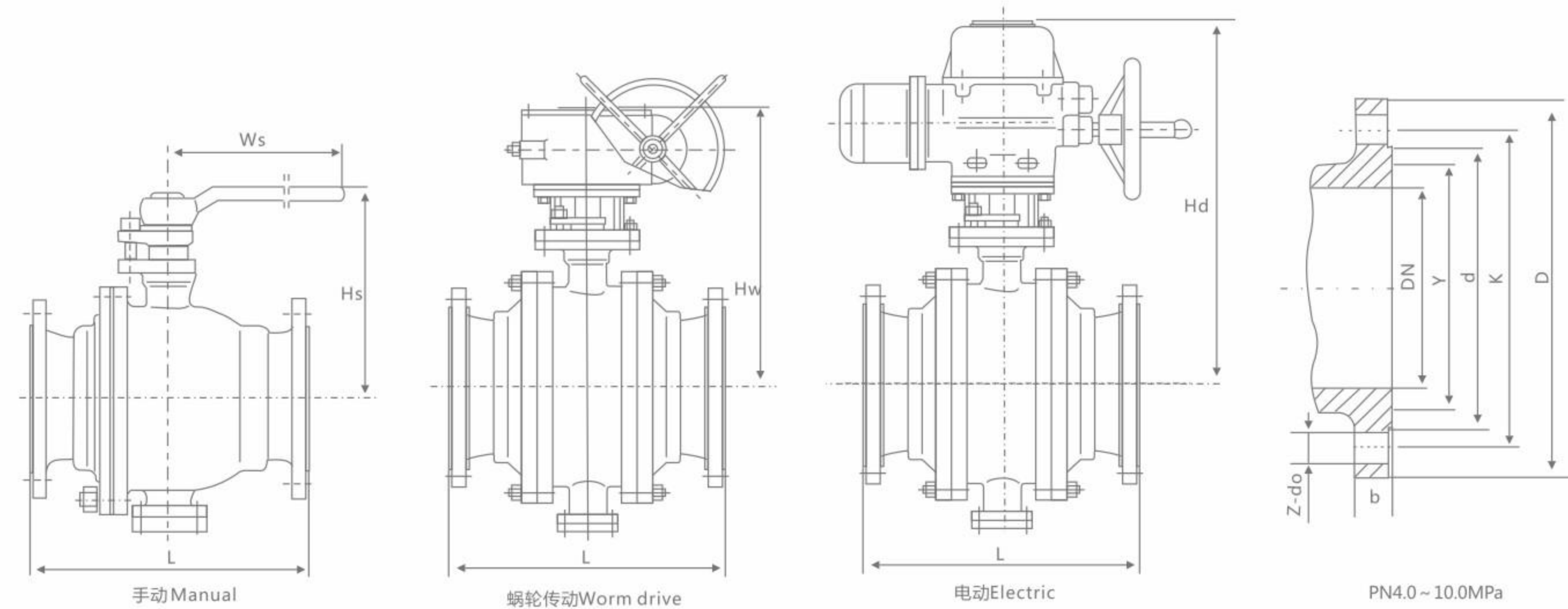

主要连接尺寸 Main connection dimensions

HG/T 20592

公称压力 PN(MPa)	公称口径 DN(mm)	尺寸Size (mm)											
		L	D	K	d	Y	b	Z-do	Ws	Hs	Hw	Hd	N.m
4.0MPa	150	403	300	250	218	204	30	8-25	1200	360	485	590	450
	200	502	375	320	282	260	38	12-30	-	-	580	640	750
	250	568	445	385	345	313	42	12-34	-	-	665	680	1250
	300	648	510	450	408	364	46	16-34	-	-	760	810	2100
	350	762	570	510	465	422	52	16-34	-	-	820	890	2800
	400	838	655	585	535	474	58	16-41	-	-	860	940	4300
	450	914	680	610	560	524	60	20-41	-	-	930	1010	5500
	500	991	755	670	612	576	62	20-48	-	-	980	1130	6800
	600	1143	890	795	730	678	62	20-54	-	-	1040	1090	11000
	700	1346	995	900	835	768	68	24-54	-	-	1150	1210	-
	800	1524	1135	1030	960	876	76	24-58	-	-	1305	1340	-
	900	1727	1270	1168	1022	-	105	32-54	-	-	1505	1600	-
	1000	1880	1238	1156	1086	-	114	32-44	-	-	1615	1705	-
	1200	2184	1467	1372	1302	-	133	32-51	-	-	1925	2035	-
1400	-	1708	1600	1518	-	154	28-60	-	-	2110	2185	-	
6.4MPa	150	495	340	280	240	204	38	8-34	1200	360	485	590	600
	200	597	405	345	300	260	44	12-34	-	-	580	650	1300
	250	673	470	400	352	313	48	12-41	-	-	665	720	2000
	300	762	530	460	412	364	54	16-41	-	-	760	840	2900
	350	826	595	525	475	422	60	16-41	-	-	820	930	3700
	400	902	670	585	525	474	66	16-48	-	-	870	990	5800
	500	1054	800	705	640	576	70	20-54	-	-	995	1150	-
	600	1232	930	820	750	678	76	20-58	-	-	1100	1180	-
	700	1397	1035	940	800	-	95	28-51	-	-	1180	1230	-
	800	1651	1149	1054	914	-	108	28-54	-	-	1345	1385	-
	900	1880	1270	1168	1022	-	114	32-54	-	-	1550	1655	-
	1000	1981	1270	1175	1092	-	133	32-51	-	-	1675	1745	-
	1200	2311	1511	1403	1308	-	152	28-60	-	-	1945	2075	-

Q47F/Y/H型固定金属密封球阀

Fixed metal seal ball valve

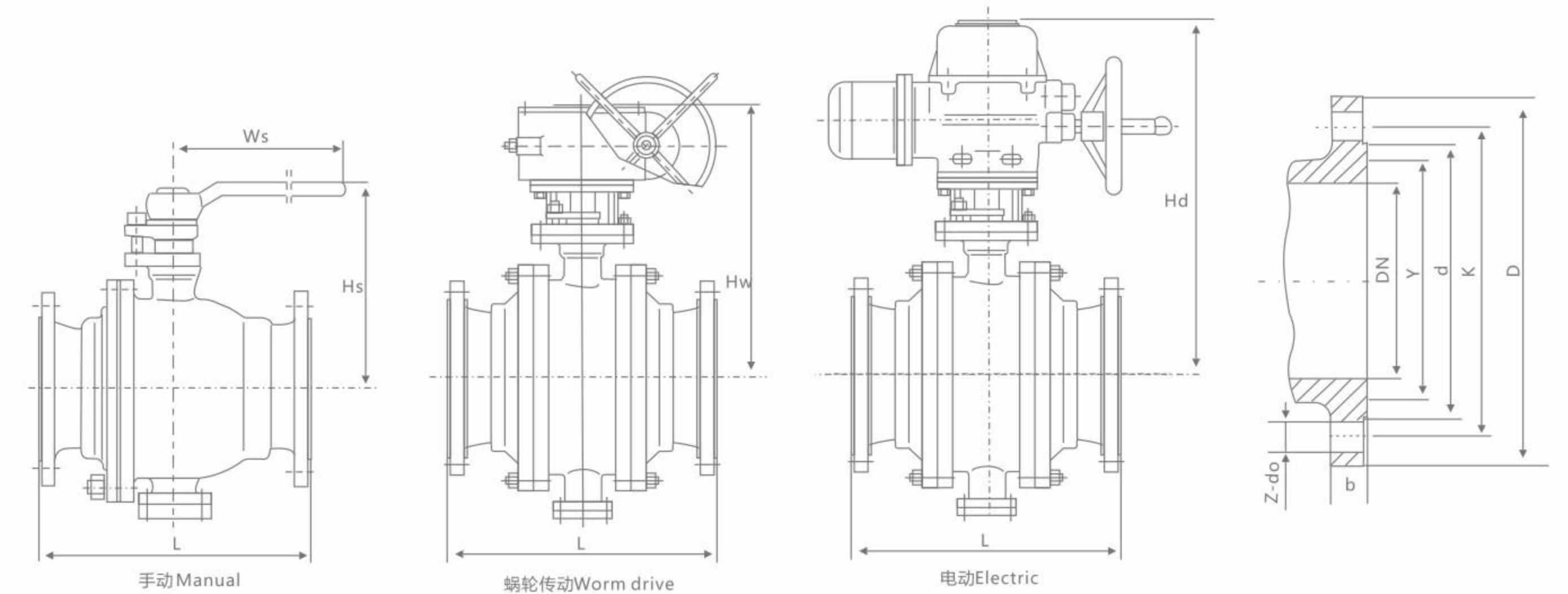

主要连接尺寸 Main connection dimensions

公称压力 PN(MPa)	公称口径 DN(mm)	尺寸Size (mm)											
		L	D	K	d	Y	b	Z-do	Ws	Hs	Hw	Hd	N.m
Class 150	2"	178	152	120.7	92	-	14.3	4-19	260	155	-	-	-
	2 1/2"	190	178	139.7	105	-	15.9	4-19	350	185	-	-	-
	3"	203	190	152.4	127	-	17.5	4-19	500	205	-	-	-
	4"	229	229	190.5	157	-	22.3	8-19	650	255	390	500	110
	5"	356	254	215.9	186	-	22.3	8-22.5	800	285	410	520	180
	6"	394	279	241.3	216	-	23.9	8-22.5	1000	305	470	540	340
	8"	457	343	298.5	270	-	27.0	8-22.5	-	-	520	580	500
	10"	533	406	362	324	-	28.6	12-25.5	-	-	610	640	830
	12"	610	483	431.8	381	-	30.2	12-25.5	-	-	650	690	1400
	14"	686	533	476.3	413	-	33.4	12-28.5	-	-	740	785	2200
	16"	762	597	539.8	470	-	35.0	16-28.5	-	-	795	830	2600
	18"	864	635	577.9	533	-	38.1	16-32	-	-	860	910	3700
	20"	914	699	635.0	584	-	41.3	20-32	-	-	945	990	4800
	24"	1067	813	749.3	692	-	46.1	20-35	-	-	1040	1090	8200
28"	1245	927	864	800	-	71	28-35	-	-	1150	1210	12000	
32"	1372	1060	978	914	-	81	28-41	-	-	1280	1340	16000	
Class 300	2"	216	165	127	92	-	20.7	8-19	260	155	-	-	-
	2 1/2"	241	190	149.2	105	-	23.9	8-22.5	350	185	-	-	-
	3"	282	210	168.3	127	-	27.0	8-22.5	500	205	-	-	-
	4"	305	254	200	157	-	30.2	8-22.5	800	270	410	530	200
	5"	381	279	235	186	-	33.4	8-22.5	1000	305	470	560	290
	6"	403	318	269.9	216	-	35.0	12-22.5	1200	340	485	590	480
	8"	502	381	330.2	270	-	39.7	12-25.5	-	-	5809	640	850
	10"	568	445	387.4	324	-	46.1	16-28.5	-	-	665	680	1400
	12"	648	521	450.8	381	-	49.3	16-32	-	-	760	810	2400
	14"	762	584	514.4	413	-	52.4	20-32	-	-	820	890	3100
	16"	838	648	571.5	470	-	55.6	20-35	-	-	860	940	4800
	18"	914	711	628.5	533	-	58.8	24-35	-	-	930	1010	6100
	20"	991	775	685.8	584	-	62.0	24-35	-	-	980	1130	7500
	2"	292	165	127	108	-	25.4	8-19	350	175	-	-	70
2 1/2"	330	190	149.2	127	-	28.6	8-22.5	500	200	-	-	120	
3"	356	210	168.3	146	-	31.8	8-22.5	650	235	-	-	280	
4"	432	273	215.9	175	-	38.1	8-25.5	1000	275	395	550	340	
5"	508	330	266.7	210	-	44.5	8-28.5	1200	325	430	580	550	
6"	559	356	292.1	241	-	47.7	12-28.5	-	-	495	620	800	
8"	660	419	349.2	302	-	55.6	12-32	-	-	595	680	1700	
10"	787	508	431.8	356	-	63.5	16-35	-	-	680	740	2800	
12"	838	559	489.0	413	-	66.7	20-35	-	-	790	850	4200	

锻钢球阀

Forged steel ball valve

结构特点及用途

- 1、抗硫化应力开裂：阀门接触介质的材料都是按美国腐蚀工程师协会 NACE0 1-75 的标准进行选择，且按标准进行表面镀镍，能满足硫化环境工况的要求。
- 2、用聚合物或金属作密封材料，在高温、高压工况具有优良的密封性能。
- 3、设置填料箱，防止阀门内腔压力异常升高而使阀杆飞出，增置倒密封结构，能确保填料可靠密封。
- 4、广泛适用于化工、炼油、油气、天然气、钢铁等介质管路。

Unique feature and use

- 1、Anti-curing stress cracking: The valve contact medium's material is corrodes Engineer according to the US the association NACE0 1-75 standards to carry on the choice, and carries on the superficial nickel plating according to the standard, can satisfy the curing environment operating mode the request.
- 2、Make the packing material with the polymer or the metal, in the high temperature, the high-pressured operating mode has the fine sealing property.
- 3、The establishment stuffing box, prevents the valve cavity pressure anomaly to elevate causes the valve lever to depart, increases ets seals the structure but actually, can guarantee that the padding seals reliably.
- 4、Widely is suitable for medium pipelines and so on chemical industry, refinery, oil gas, natural gas, steel and iron.

执行标准 Implementation of standards

- 1、设计和制造 Design and manufacture :
GB/T 12237;API 608
- 2、检验和试验 Inspection and test :
GB/T 13927;API 598
- 3、法兰连接 Flange connection :
JB/T 79.1-4;ASME/ANSI B 16.5
- 4、结构长度 Structure length :
GB/T 12221;GB/T 15188.1
ASME/ANSI B 16.10

性能规范 Performance Specifications

试验压力 Test pressure

单位 Unit : MPa

使用范围 Terms of use

公称压力 PN	常温最大工作压力 Max temperature Working pressure	壳体试验压力 Case Test pressure	气密封试验压力 Gas Seals test pressure	高压密封试验压力 High-pressure sealing test pressure
1.6	1.6	2.4	0.6	1.76
2.5	2.5	3.8	0.6	2.75
4.0	4.0	6.0	0.6	4.4
6.4	6.4	9.6	0.6	7.1
10.0	10.0	15.0	0.6	11.0
16.0	16.0	24.0	0.6	17.6
20.0	20.0	30.0	0.6	22.0
25.0	25.0	37.5	0.6	27.5
Class 150	2.0	3.0	0.6	2.2
Class 300	5.0	7.5	0.6	5.5
Class 600	10.0	15.0	0.6	11.0
Class 900	15.0	22.5	0.6	16.5
Class 1500	25.0	37.5	0.6	27.5

壳体材料 Shell material	阀座材料 Seat Material	适用温度 Applicable medium	适用介质 Applicable temperature
碳钢 C 型 Carbon Steel C	PTFE	≤150°C	水、蒸汽、油品等 Water, steam, oil, etc.
	PTFE	≤150°C	
铬镍钛钢 P 型 Chrome P-type nickel-titanium steel	不锈钢 Stainless steel	≤425°C	硝酸类 Nitric acid
	PTFE	≤150°C	
铬镍钼钛钢 R 型 Chrome-nickel steel R-Mo Ti	PTFE	≤150°C	醋酸类 Acetic acid
	不锈钢 Stainless steel	≤200°C	
铬钼钢 I 型 Cr-Mo steel I-V	硬质合金 Hard alloy	≤550°C	蒸汽、冶炼、能源等 Steam, metallurgical, energy, etc.

主要零件材料 Main components material

阀体、阀盖、填料箱 Body, bonnet Packing Box	球体 Ball	阀杆、固定轴 Stem, fixed axis	阀座 Seat	填料 Packing	螺栓 Bolt	螺母 Nut
GB 25	GB 2Cr13/表面特殊处理 Special surface treatment	GB 2Cr13	GB PTFE	GB PTFE	GB 35	GB 45
ASTM 1025	ASTM 420	ASTM 420	ASTM PTFE	ASTM PTFE	ASTM A193 B7	ASTM A194 2H
1Cr18Ni9Ti	1Cr18Ni9Ti/表面特殊处理 Special surface treatment	0Cr18Ni9	PTFE	柔性石墨 Flexible Graphite	0Cr18Ni9	1Cr13
304	304+HF	304	PTFE	柔性石墨 Flexible Graphite	A320-B8	A194-8
0Cr18Ni12Mo2Ti	0Cr18Ni12Mo2Ti/表面特殊处理 Special surface treatment	0Cr17Ni12Mo2	PTFE	柔性石墨 Flexible Graphite	A320-B8	A194-8
316	316+HF	316	PTFE	柔性石墨 Flexible Graphite	15Cr1Mo1V	20CrMo
F22a	F22a+HF	F22a	F22a	柔性石墨 Flexible Graphite	A193 B16	A194-4

锻钢球阀

Forged steel ball valve

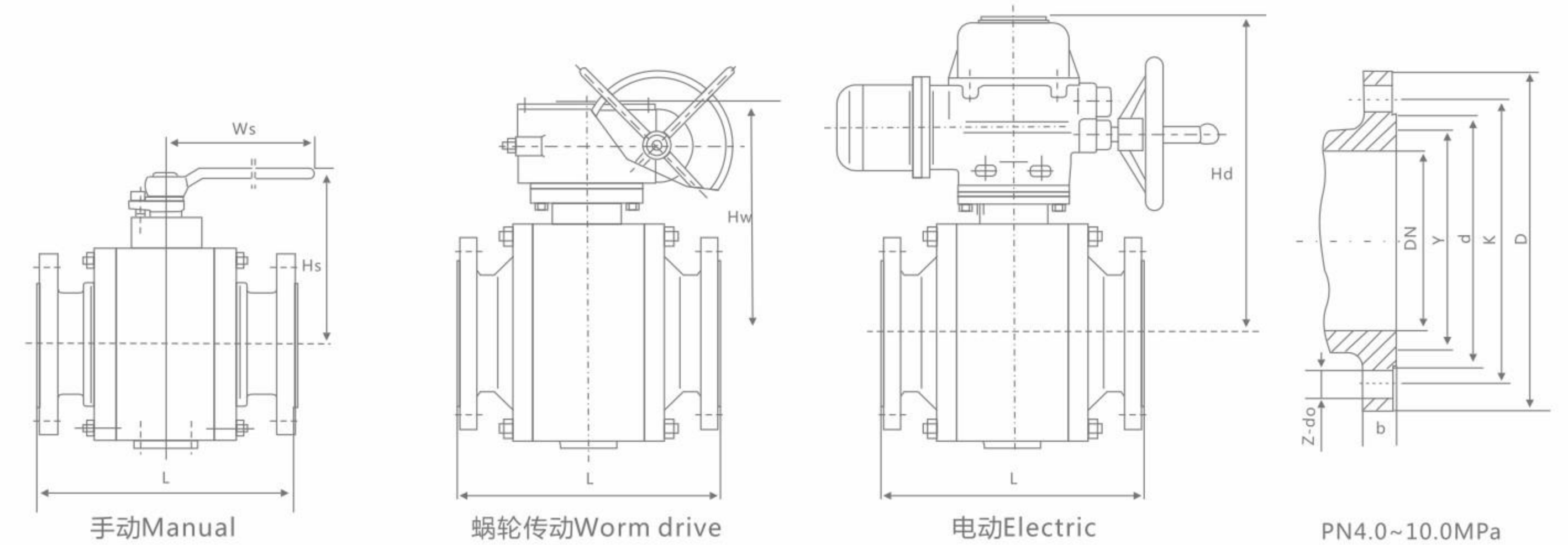

主要连接尺寸 Main connection dimensions

HG/T 20592

公称压力 PN	公称口径 DN	尺寸 Size (mm)										
		L	D	K	d	Y	b	Z-do	Ws	Hs	Hw	Hd
1.6MPa	40	165	145	110	85	-	16	4-18	230	135	-	-
	50	203	160	125	100	-	16	4-18	260	150	-	-
	65	222	180	145	120	-	18	4-18	350	180	-	-
	80	241	195	160	135	-	20	8-18	500	195	-	-
	100	305	215	180	155	-	20	8-18	650	245	310	420
	125	356	245	210	185	-	22	8-18	800	270	330	440
	150	394	280	240	210	-	24	8-23	1000	295	390	470
	200	457	335	295	265	-	26	12-23	-	-	440	510
	250	533	405	355	320	-	30	12-25	-	-	490	560
	300	610	460	410	375	-	30	12-25	-	-	530	600
	350	686	520	470	435	-	34	16-25	-	-	620	670
	400	762	580	525	485	-	36	16-30	-	-	675	720
450	864	640	585	545	-	40	20-30	-	-	740	790	
500	914	705	650	608	-	44	20-34	-	-	825	870	
600	1067	840	770	718	-	48	20-41	-	-	920	960	
2.5MPa	40	190	145	110	85	-	18	4-18	230	135	-	-
	50	216	160	125	100	-	20	4-18	260	150	-	-
	65	241	180	145	120	-	22	8-18	350	180	-	-
	80	283	195	160	135	-	22	8-18	500	195	-	-
	100	305	230	190	160	-	24	8-23	650	245	310	420
	125	381	270	220	188	-	28	8-25	800	270	330	440
	150	403	300	250	218	-	30	8-25	1000	295	390	470
	200	502	360	310	278	-	34	12-25	-	-	440	510
	250	568	425	370	332	-	36	12-30	-	-	490	560
	300	648	485	430	390	-	40	16-30	-	-	530	600
	350	762	550	490	448	-	44	16-034	-	-	620	670
	400	838	610	550	505	-	48	16-34	-	-	675	720
450	914	660	600	555	-	50	20-34	-	-	740	790	
500	991	730	660	610	-	52	20-41	-	-	825	870	
600	1143	840	770	718	-	56	20-41	-	-	920	960	

锻钢球阀 Forged steel ball valve

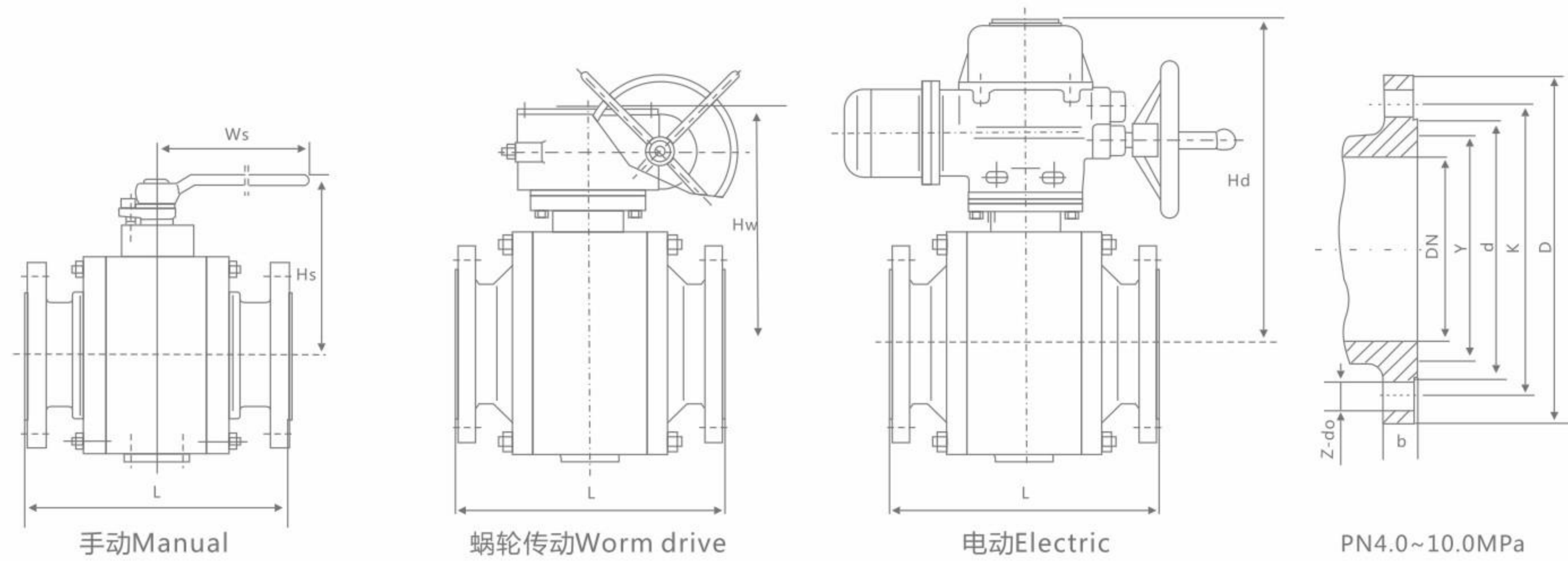

锻钢球阀 Forged steel ball valve

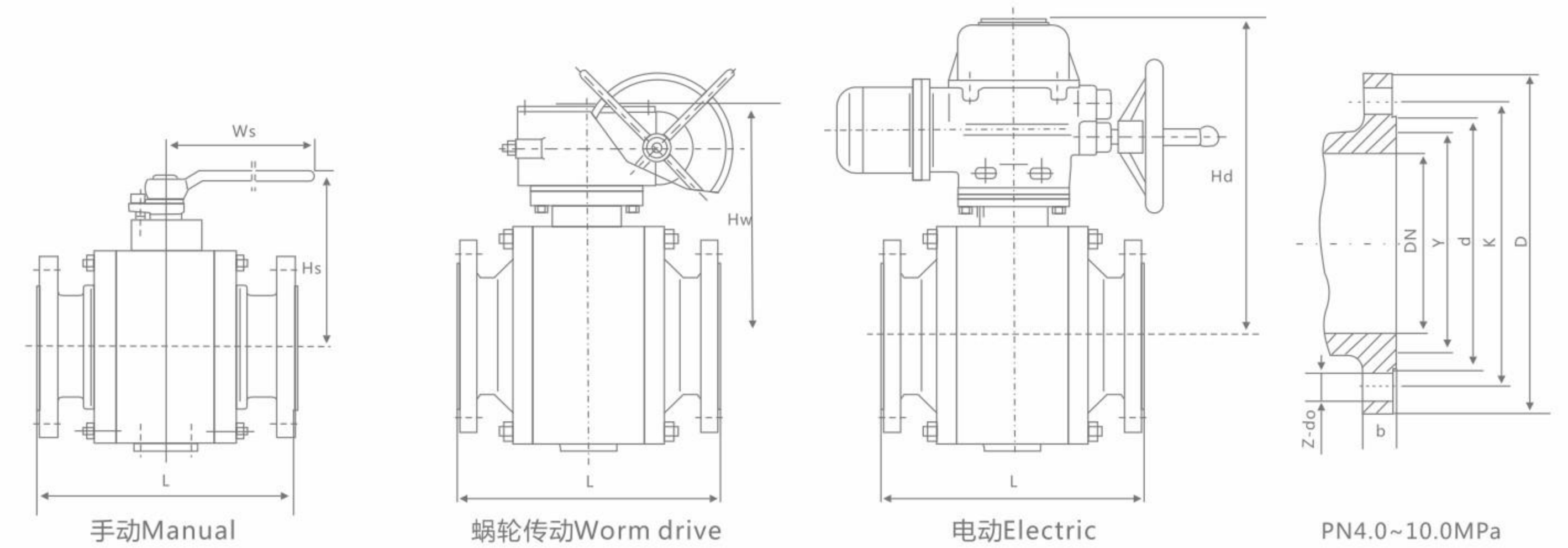

主要连接尺寸 Main connection dimensions

HG/T 20592

公称压力 PN	公称口径 DN	尺寸Size (mm)										
		L	D	K	d	Y	b	Z-do	Ws	Hs	Hw	Hd
4.0MPa	40	190	145	110	85	76	18	4-18	230	135	-	-
	50	216	160	125	100	88	20	4-18	260	150	-	-
	65	241	180	145	120	110	22	8-18	350	180	-	-
	80	283	195	160	135	121	22	8-18	500	195	-	-
	100	305	230	190	160	150	24	8-23	800	250	320	430
	125	381	270	220	188	176	28	8-25	1000	280	340	450
	150	403	300	250	218	204	30	8-25	1200	300	405	480
	200	502	375	320	282	260	38	12-30	-	-	450	530
	250	568	445	385	345	313	42	12-34	-	-	505	590
	300	648	510	450	408	364	46	16-34	-	-	545	620
6.3MPa	40	241	165	125	95	76	24	4-23	260	140	-	-
	50	292	175	135	105	88	26	4-23	260	160	-	-
	65	330	200	160	130	110	28	8-23	350	180	-	-
	80	356	210	170	140	121	30	8-23	500	220	-	-
	100	406	250	200	168	150	32	8-25	800	250	320	430
	125	400	295	240	202	176	36	8-30	1000	295	340	450
	150	495	340	280	240	204	38	8-34	1200	340	405	480
	200	597	405	345	300	260	44	12-34	-	-	450	530
	250	673	470	400	352	313	48	12-41	-	-	505	590
	300	762	530	460	412	364	54	16-41	-	-	545	620
10.0MPa	40	241	165	125	95	76	24	4-23	260	140	-	-
	50	292	175	135	105	88	26	4-23	260	160	-	-
	65	330	200	160	130	110	28	8-23	350	180	-	-
	80	356	210	170	140	121	30	8-23	500	220	-	-
	100	406	250	200	168	150	32	8-25	800	250	320	430
	125	400	295	240	202	176	36	8-30	1000	295	340	450
	150	495	340	280	240	204	38	8-34	1200	340	405	480
	200	597	405	345	300	260	44	12-34	-	-	450	530
	250	673	470	400	352	313	48	12-41	-	-	505	590
	300	762	530	460	412	364	54	16-41	-	-	545	620
16.0MPa	40	241	165	125	95	76	24	4-23	260	140	-	-
	50	292	175	135	105	88	26	4-23	260	160	-	-
	65	330	200	160	130	110	28	8-23	350	180	-	-
	80	356	210	170	140	121	30	8-23	500	220	-	-
	100	406	250	200	168	150	32	8-25	800	250	320	430
	125	400	295	240	202	176	36	8-30	1000	295	340	450
	150	495	340	280	240	204	38	8-34	1200	340	405	480
	200	597	405	345	300	260	44	12-34	-	-	450	530
	250	673	470	400	352	313	48	12-41	-	-	505	590
	300	762	530	460	412	364	54	16-41	-	-	545	620
20.0MPa	40	241	165	125	95	76	24	4-23	260	140	-	-
	50	292	175	135	105	88	26	4-23	260	160	-	-
	65	330	200	160	130	110	28	8-23	350	180	-	-
	80	356	210	170	140	121	30	8-23	500	220	-	-
	100	406	250	200	168	150	32	8-25	800	250	320	430
	125	400	295	240	202	176	36	8-30	1000	295	340	450
	150	495	340	280	240	204	38	8-34	1200	340	405	480
	200	597	405	345	300	260	44	12-34	-	-	450	530
	250	673	470	400	352	313	48	12-41	-	-	505	590
	300	762	530	460	412	364	54	16-41	-	-	545	620
25.0MPa	40	241	165	125	95	76	24	4-23	260	140	-	-
	50	292	175	135	105	88	26	4-23	260	160	-	-
	65	330	200	160	130	110	28	8-23	350	180	-	-
	80	356	210	170	140	121	30	8-23	500	220	-	-
	100	406	250	200	168	150	32	8-25	800	250	320	430
	125	400	295	240	202	176	36	8-30	1000	295	340	450
	150	495	340	280	240	204	38	8-34	1200	340	405	480
	200	597	405	345	300	260	44	12-34	-	-	450	530
	250	673	470	400	352	313	48	12-41	-	-	505	590
	300	762	530	460	412	364	54	16-41	-	-	545	620

主要连接尺寸 Main connection dimensions

HG/T 20592

公称压力 PN	公称口径 DN	尺寸Size (mm)										
		L	D	K	d	Y	b	Z-do	Ws	Hs	Hw	Hd
10.0MPa	40	241	165	125	95	76	24	4-23	260	140	-	-
	50	292	175	135	105	88	26	4-23	260	160	-	-
	65	330	200	160	130	110	28	8-23	350	180	-	-
	80	356	210	170	140	121	30	8-23	500	220	-	-
	100	406	250	200	168	150	32	8-25	800	250	320	430
	125	400	295	240	202	176	36	8-30	1000	295	340	450
	150	495	340	280	240	204	38	8-34	1200	340	405	480
	200	597	405	345	300	260	44	12-34	-	-	450	530
	250	673	470	400	352	313	48	12-41	-	-	505	590
	300	762	530	460	412	364	54	16-41	-	-	545	620
16.0MPa	40	241	165	125	95	76	24	4-23	260	140	-	-
	50	292	175	135	105	88	26	4-23	260	160	-	-
	65	330	200	160	130	110	28	8-23	350	180	-	-
	80	356	210	170	140	121	30	8-23	500	220	-	-
	100	406	250	200	168	150	32	8-25	800	250	320	430
	125	400	295	240	202	176	36	8-30	1000	295	340	450
	150	495	340	280	240	204	38	8-34	1200	340	405	480
	200	597	405	345	300	260	44	12-34	-	-	450	530
	250	673	470	400	352	313	48	12-41	-	-	505	590
	300	762	530	460	412	364	54	16-41	-	-	545	620
20.0MPa	40	241	165	125	95	76	24	4-23	260	140	-	-
	50	292	175	135	105	88	26	4-23	260	160	-	-
	65	330	200	160	130	110	28	8-23	350	180	-	-
	80	356	210	170	140	121	30	8-23	500	220	-	-
	100	406	250	200	168	150	32	8-25	800	250	320	430
	125	400	295	240	202	176	36	8-30	1000	295	340	450
	150	495	340	280	240	204	38	8-34	1200	340	405	480
	200	597	405	345	300	260	44	12-34	-	-	450	530
	250	673	470	400	352	313	48	12-41	-	-	505	590
	300	762	530	460	412	364	54	16-41	-	-	545	620
25.0MPa	40	241	165	125	95	76	24	4-23	260	140	-	-
	50	292	175	135	105	88	26	4-23	260	160	-	-
	65	330	200	160	130	110	28	8-23	350	180	-	-
	80	356	210	170	140	121	30	8-23	500	220	-	-
	100	406	250	200	168	150	32	8-25	800	250	320	430
	125	400	295	240	202	176	36	8-30	1000	295	340	450
	150	495	340	280	240	204	38	8-34	1200	340	405	480
	200	597	405	345	300	260	44	12-34	-	-	450	530
	250	673	470	400	352	313	48	12-41	-	-	505	590
	300	762	530	460	412	364	54	16-41	-	-	545	620

国标浮动球阀 GB Floating ball valve

结构特点 Structure characteristics

浮动软密封不锈钢球阀用于PN16~PN63的各种管路上,用于截断或接通管路中的介质,选用不同的材质,可分别适用于水、蒸汽、油品、液化气、天然气、煤气、醋酸、氧化性介质、尿素等多种介质。

- a. 在各种阀门中,球阀的流动阻力最小,全径球阀打开时,球体通道、阀体通道和连接管径相等并成一直径,介质几乎可以毫无损失的流过。
b. 球阀旋转90°即可全开全关,启闭迅速。与相同规格的闸阀、截止阀比较,球阀体积小、重量轻、便于管道安装。

Soft floating seal stainless steel ball valve used for PN16 ~ PN63 various piping, used to truncate or on line in the medium, choose no material, can be respectively suitable for water, steam, oil, liquefied petroleum gas, natural gas, coal gas, acetic acid, oxidizing medium, urea, and other media.

A, in all kinds of valve, ball valve flow resistance of the smallest, full bore ball valve is opened, the sphere channels, the body and connected to equal diameter and diameter, flow medium can be almost no losses.

B, ball valve can be rotated 90° seated fully open, opening and closing fast. Compared with the same specifications of the gate valve, globe valve, ball valve, small volume, light weight, easy to pipeline installation.

标准与规范 Standards and norms

设计标准 Design standard	结构长度 Face to Face	法兰连接尺寸 Flange End	试验与检验 Test & Check	压力-温度 Pressure-Temp.
GB/T 12237 API6D	GB/T 12221	JB/T 79 HG20592	GB/T 26480	GB/T 12224 ASME B16.34

性能参数 performance parameters

序号 NO.	项目名称 Project name	项目名称 Project name			
		PN16	PN25	PN40	PN64
1	公称压力 (MPa)	1.6	2.5	4.0	6.4
2	壳体强度试验压力 (MPa) Shell strength test pressure	常温下公称压力的1.5倍 1.5 Times the nominal pressure at room temperature			
3	高压密封试验压力 (MPa) High pressure seal test pressure	常温下公称压力的1.1倍 1.1 Times the nominal pressure at room temperature			
4	常温下工作压力 (MPa) Operating pressure at room temperature	≤1.6	≤2.5	≤4.0	≤6.4

主要零件材料 Materials for Main Parts

名称 Name	材料 Material								
阀体/阀盖 Body/Bonnet	CF8	CF3	CF8M	CF3M	WCB	LCB	WC6	WC9	C5
球体 Ball	CF8	CF3	CF8M	CF3M	WCB Hcr	CF8	CF8	CF8	CF8
阀杆 Stem	F304	F304L	F316	F316L	2CR13	F304	F304	F304	F304
阀座 Seat	PTFE/PPL/304								
填料/垫片 Packing/Gasket	PTFF					石墨 Graphite			
螺栓 Bolt	不锈钢 Stainless Steel					35CrMoA			
螺母 Nut	不锈钢 Stainless Steel					45、35CrMoA			
手柄 Handle	铸钢 Cast Steel								

国标浮动球阀 GB Floating ball valve

Q41/641/941F-16C/P/R/RL

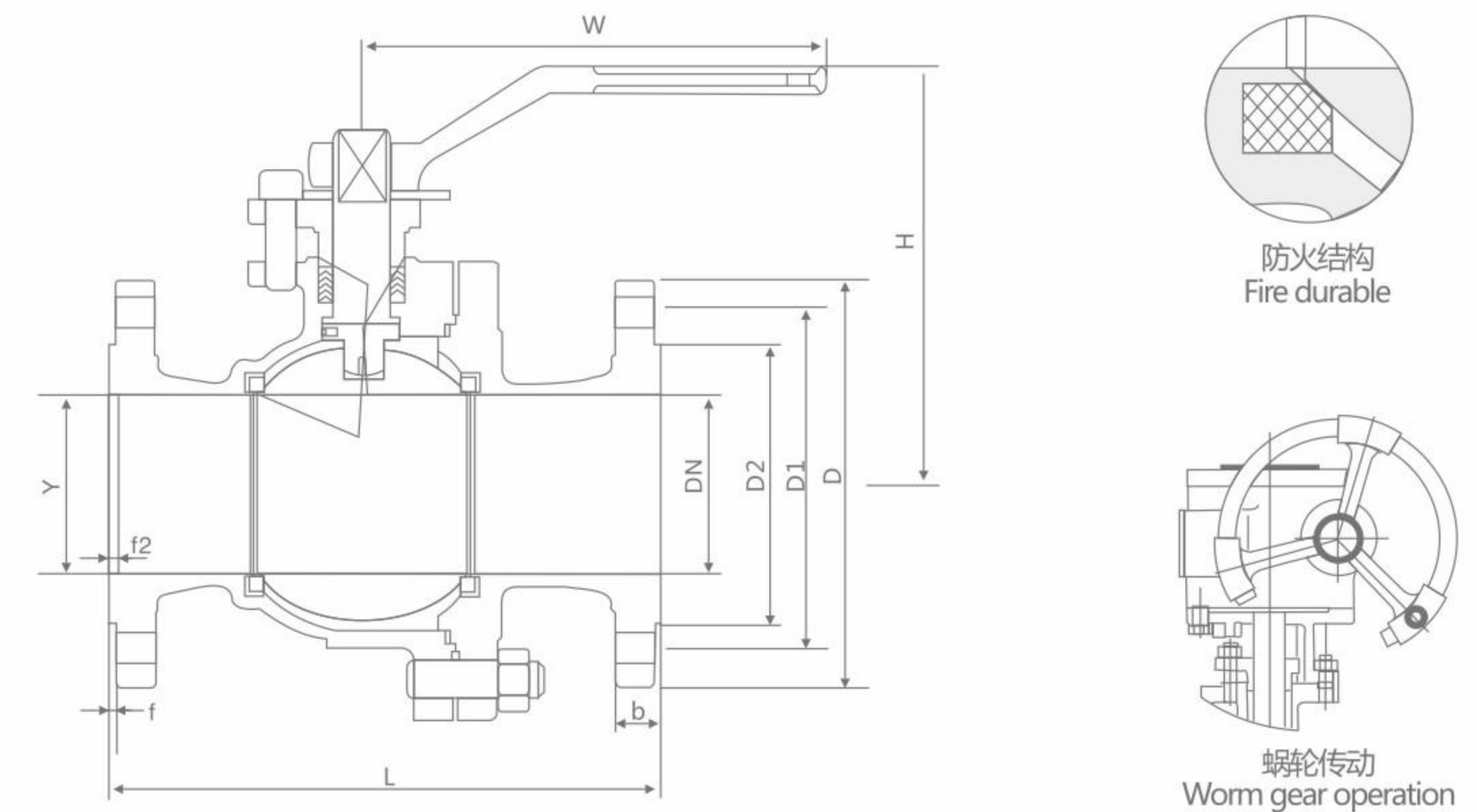

主要外形和连接尺寸 Main external and connection dimension

HG/T 20592
单位 Unit:mm

公称通径 DN	主要外形和连接尺寸 Main external and connecting dimensions									N.m	WT (kg)	
	L	D	D1	D2	b	f	Z-φd	H	W			
	Q41F-16C		Q41F-16P		Q641F-16C		Q641F-16P		Q9B41F-16C		Q9B41F-16P	
15	130	95	65	45	16	2	4-φ14	78	140	6	3	
20	140/130	105	75	55	18	2	4-φ14	84	160	9	4	
25	150/140	115	85	65	18	2	4-φ14	95	180	14	5	
32	165	140	100	78	18	2	4-φ18	150	250	22	9	
40	180/165	150	110	85	18	2	4-φ18	150	300	32	11	
50	200/203	165	125	100	18	2	4-φ18	170	350	40	15	
65	220/222	185	145	120	18	2	8-φ18	195	350	60	19	
80	250/241	200	160	135	20	2	8-φ18	215	400	90	27	
100	280/305	220	180	155	20	2	8-φ18	250	500	130	38	
125	320/356	250	210	185	22	3	8-φ18	265	600	250	58	
150	360/394	285	240	210	22	3	8-φ22	270	800	490	81	
200	400/457	340	295	265	24	3	12-φ22	330	800	860	95	
250	533	405	355	320	26	3	12-φ26	450	1300	-	140	

国标浮动球阀
GB Floating ball valve

Q41/341/641/941P-25~64/

HG/T 20592

主要外形和连接尺寸 Main external and connection dimension

单位Unit:mm

公称通径 DN	主要外形和连接尺寸 Main external and connection dimensions										N.m	WT (kg)
	L	D	D1	D2	b	Y	f2	Z-φd	H	W		
Q41F-25C Q41F-25P Q641F-25C Q641F-25P Q9B41F-25C Q9B41F-25P												
15	130	95	65	45	16	-	-	4-φ14	103	100	8	3
20	140	105	75	55	18	-	-	4-φ14	112	160	12	4
25	150	115	85	65	18	-	-	4-φ14	123	160	18	6
32	165	140	100	78	18	-	-	4-φ18	150	250	28	10
40	180	150	110	85	18	-	-	4-φ18	156	250	40	14
50	200	165	125	100	20	-	-	4-φ18	172	350	55	20
65	220	185	145	120	22	-	-	8-φ18	197	350	85	25
80	250	200	160	135	24	-	-	8-φ18	222	450	130	30
100	280	235	190	160	24	-	-	8-φ22	253	450	190	40
125	320	270	220	188	26	-	-	8-φ26	275	600	320	65
150	360	300	250	218	28	-	-	8-φ26	286	800	620	85
200	400	360	310	278	30	-	-	12-φ26	340	1200	1100	100
250	533	425	370	332	32	-	-	12-φ30	470	1400	-	165
Q41F-40C Q41F-40P Q341F-40C Q341F-40P Q641F-40C Q641F-40P Q9B41F-40C Q9B41F-40P												
15	130	95	65	45	16	40	4	4-φ14	103	100	10	3
20	140	105	75	55	18	51	4	4-φ14	112	160	15	4
25	150	115	85	65	18	58	4	4-φ14	123	160	23	6
32	180	140	100	78	18	66	4	4-φ18	150	250	32	10
40	200	150	110	85	18	76	4	4-φ18	156	250	45	14
50	220	165	125	100	20	88	4	4-φ18	172	350	65	20
65	250	185	145	120	22	110	4	8-φ18	197	350	95	25
80	280	200	160	135	24	121	4	8-φ18	222	450	150	30
100	320	235	190	160	24	150	4.5	8-φ22	253	450	260	40
125	400	270	220	188	26	176	4.5	8-φ26	275	600	550	65
150	400	300	250	218	28	204	4.5	8-φ26	286	800	900	85
200	550	375	320	282	34	260	4.5	12-φ30	340	1200	1800	100
250	568	450	385	345	38	313	4.5	12-φ33	470	1400	-	165
Q41F-63C Q41F-63P Q341F-63C Q341F-63P Q641F-63C Q641F-63P Q9B41F-63C Q9B41F-63P												
15	140	105	75	55	20	40	4	4-φ14	105	130	15	3.1
20	155	130	90	68	22	51	4	4-φ18	125	130	20	4.9
25	180	140	100	78	24	58	4	4-φ18	135	160	35	7.2
32	200	155	110	82	26	66	4	4-φ22	150	160	50	8.7
40	220	170	125	95	28	76	4	4-φ22	165	230	70	12.1
50	250	180	135	105	26	88	4	4-φ22	175	230	85	16.7
65	280	205	160	130	26	110	4	8-φ22	200	400	130	28.2
80	320	215	170	140	28	121	4	8-φ22	210	400	200	36
100	350	250	200	168	30	150	4.5	8-φ26	250	700	340	66
125	455	295	240	202	34	176	4.5	8-φ30	295	1100	-	98
150	495	345	280	240	36	204	4.5	8-φ33	340	1500	-	142



02

RUITONG VALVE

闸阀 GATE VALVE SERIES
系列

美标闸阀 API Gate valves

Z41W-150Lb

一、产品概述 Product overview

法兰连接钢制闸阀适用于ANSI Class150~900、PN2.0~16.0MPa、JIS10~20K，工作温度-29~425℃（碳钢）及-40~500℃（不锈钢）的各种管路上，用于截断或接通管路中的介质。通过选用不同的材质，可适用于水、蒸汽、油品、硝酸、醋酸、强氧化性介质及尿素等多种介质。有手动、伞齿轮传动及电动等。

二、结构特点 Structural characteristics of

- 1、产品设计制造符合国外先进标准要求，密封可靠，性能优良。
- 2、结构设计紧凑合理，造型美观。
- 3、采用楔式弹性闸板结构，中大口径设置滚动轴承，启闭轻松。
- 4、阀体材料品种齐全，填料、垫片根据实际工况或用户要求合理选配，可适用于各种压力、温度及介质工况。
- 5、采用国内外多种配管法兰标准及法兰密封面型式，满足各种工程需要及用户要求

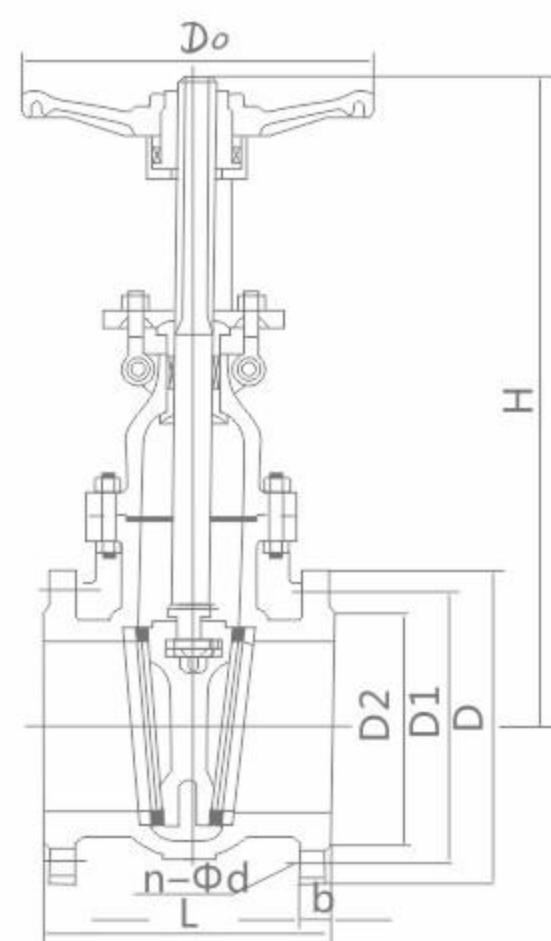

三、主要零件材料 Main components material

名称 Name	材料 Material								
阀体/阀盖 Body/Bonnet	CF8	CF3	CF8M	CF3M	WCB	LCB	WC6	WC9	C5
闸板 Wedge	CF8	CF3	CF8M	CF3M	WCB	LCB	WC6	WC9	C5
阀杆 Stem	F304	F304L	F316	F316L	2CR13	F304	F304	F304	F304
阀杆螺母 Stem Nut	铝青铜 Aluminium Bronze								
填料 Packing	PTFE/柔性石墨				石墨 Graphite				
垫片 Gasket	PTFE/金属缠绕垫				石墨 Graphite				
压盖 Gland	CF8	CF3	CF8M	CF3M	WCB	LCB	WC6	WC9	C5
螺栓 Bolt	不锈钢 Stainless Steel				35CrMoA				
螺母 Nut	不锈钢 Stainless Steel				45、35CrMoA				
手轮 Handwheel	铸钢 Cast Steel								

四、主要外形尺寸及连接尺寸 Main external and connection dimension

Class(150Lb)

规格 inch	尺寸 (mm)								
	DN	L	D	D1	D2	b	Z-Φd	H	D0
1/2"	15	108	89	60.5	35	12	4-Φ15	155	120
3/4"	20	117	98	70	43	12	4-Φ15	160	120
1"	25	127	108	79.5	51	12	4-Φ15	200	140
1"	32	140	117	89	64	13	4-Φ15	245	160
1 1/2"	40	165	127	98.5	73	15	4-Φ15	285	180
2"	50	178	152	120.5	92	16	4-Φ19	315	200
2 1/2"	65	190	178	139.5	105	18	4-Φ19	375	220
3"	80	203	190	152.5	127	19	4-Φ19	400	240
4"	100	229	229	190.5	157	24	8-Φ19	460	280
5"	125	254	254	216	186	24	8-Φ22	540	300
6"	150	267	279	241.5	216	26	8-Φ22	620	320
8"	200	292	343	298.5	270	29	8-Φ22	800	400
10"	250	330	406	362	324	31	12-Φ25	850	450
12"	300	356	483	432	381	32	12-Φ25	1000	500
14"	350	381	533	476	413	35	12-Φ29	1300	600
16"	400	406	597	540	470	37	16-Φ29	1400	600
18"	450	432	635	578	533	40	16-Φ32	1600	650
20"	500	457	398	635	584	43	20-Φ32	1850	650
24"	600	508	813	749.5	692	48	20-Φ35	2200	700

美标闸阀 API Gate valves

Class(300Lb)

规格 inch	尺寸 (mm)								
	DN	L	D	D1	D2	B	Z-Φd	H	H
1/2"	15	140	95	66.5	35	15	4-Φ15	155	120
3/4"	20	152	117	82.5	43	16	4-Φ19	160	120
1"	25	165	124	89	51	18	4-Φ19	200	140
1 1/4"	32	178	133	98.5	64	19	4-Φ19	250	160
1 1/2"	40	190	156	114.5	73	21	4-Φ22	290	180
2"	50	216	165	127	92	22	8-Φ19	330	200
2"	65	241	190	149	105	25	8-Φ22	385	220
3"	80	283	210	168.5	127	29	8-Φ22	410	240
4"	100	305	254	200	157	32	8-Φ22	480	280
5"	125	381	279	235	186	35	8-Φ22	630	300
6"	150	403	318	270	216	37	12-Φ22	690	320
8"	200	419	381	330	270	41	12-Φ25	830	400
10"	250	457	445	387.5	324	48	16-Φ29	1003	450
12"	300	502	521	451	381	51	16-Φ32	1137	500
14"	350	762	584	514.5	413	54	20-Φ32	1489	600
16"	400	838	648	571.5	470	57	20-Φ35	1581	600
18"	450	914	711	628.5	533	60	24-Φ35	2017	650
20"	500	991	775	686	584	64	24-Φ35	2228	650
24"	600	1143	914	813	692	70	24-Φ41	2650	700

Class(600Lb)

规格 inch	尺寸 (mm)								
	DN	L	D	D1	D2	B	Z-Φd	H	H
1/2"	15	165	95	66.5	35	15	4-Φ15	155	155
3/4"	20	190	118	82.5	43	16	4-Φ19	160	160
1"	25	216	124	89	51	18	4-Φ19	200	200
1 1/4"	32	229	133	98.5	64	21	4-Φ19	250	250
1 1/2"	40	241	156	114.5	73	23	4-Φ22	290	290
2"	50	292	165	127	92	26	8-Φ19	350	350
2"	65	330	190	149	105	29	8-Φ22	430	430
3"	80	356	210	168	127	32	8-Φ22	470	470
4"	100	432	273	216	157	38	8-Φ25	570	570
5"	125	508	330	266.5	186	45	8-Φ29	700	700
6"	150	559	356	292	216	48	12-Φ29	750	750
8"	200	660	419	349	270	56	12-Φ32	830	830
10"	250	787	508	432	324	64	16-Φ35	1210	1210
12"	300	838	559	489	381	67	20-Φ35	1350	1350
14"	350	889	603	527	413	70	20-Φ38	1600	1600
16"	400	991	686	603	470	77	20-Φ41	1800	1800
18"	450	1092	743	654	533	83	20-Φ44	2110	2110
20"	500	1194	813	724	584	89	24-Φ22	2350	2350
24"	600	1397	940	838	692	102	24-Φ52	2900	2900

日标闸阀 JIS gate valve

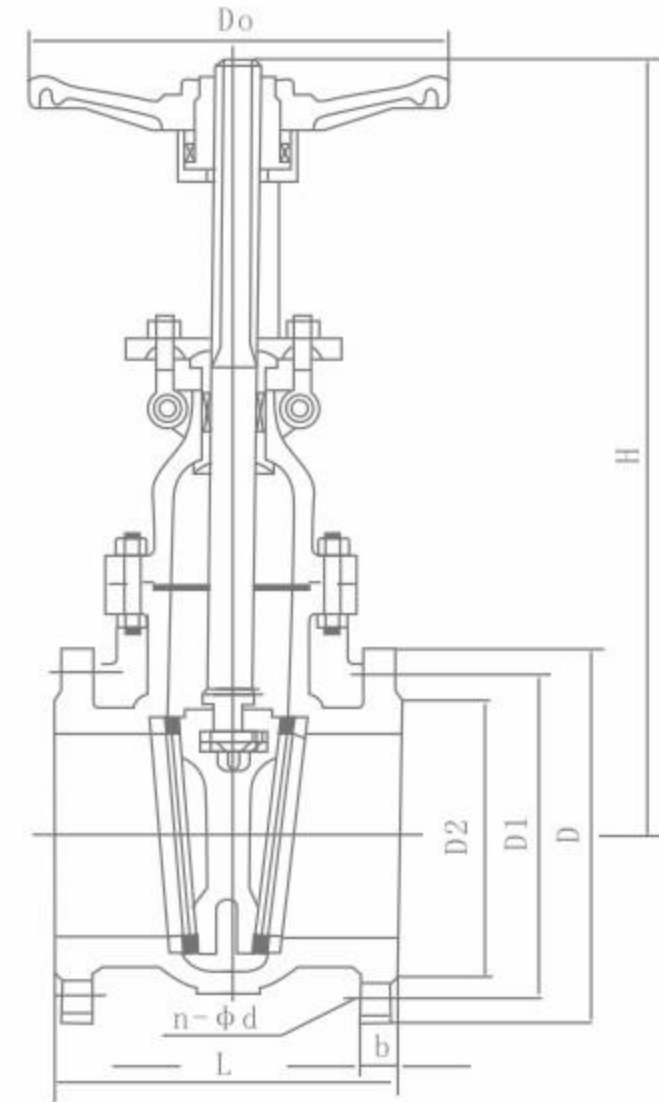

执行标准 Execution standard

设计与制造 Design and Manufacture	结构长度 Structure Length	连接法兰 Connection flange	压力-温度等级 Pressure-temperature rating	试验-检验 Test and Inspection
JIS B2073 B2083	JIS B2002	JIS B2212 B2214	JIS B2073 B2083	JIS B2003

规格主要尺寸 Main size

DN		10K		
mm	in	L	H	D0
50	2	178	409	200
65	2½	190	535	250
80	3	203	570	250
100	4	229	590	250
150	6	267	630	300
200	8	292	960	350
250	10	330	1158	400
300	12	356	1378	450
350	14	381	1543	500
400	16	406	1738	600
450	18	432	1959	600
500	20	457	2214	680
20K				
50	2	216	480	200
65	2½	241	510	250
80	3	283	580	280
100	4	305	700	350
150	6	403	940	400
200	8	419	1190	450
250	10	457	1390	500
300	12	502	1600	500
350	14	762	1750	600
400	16	838	1900	600
450	18	914	2320	650

俄标闸阀 GOST gate valve

GOST9544

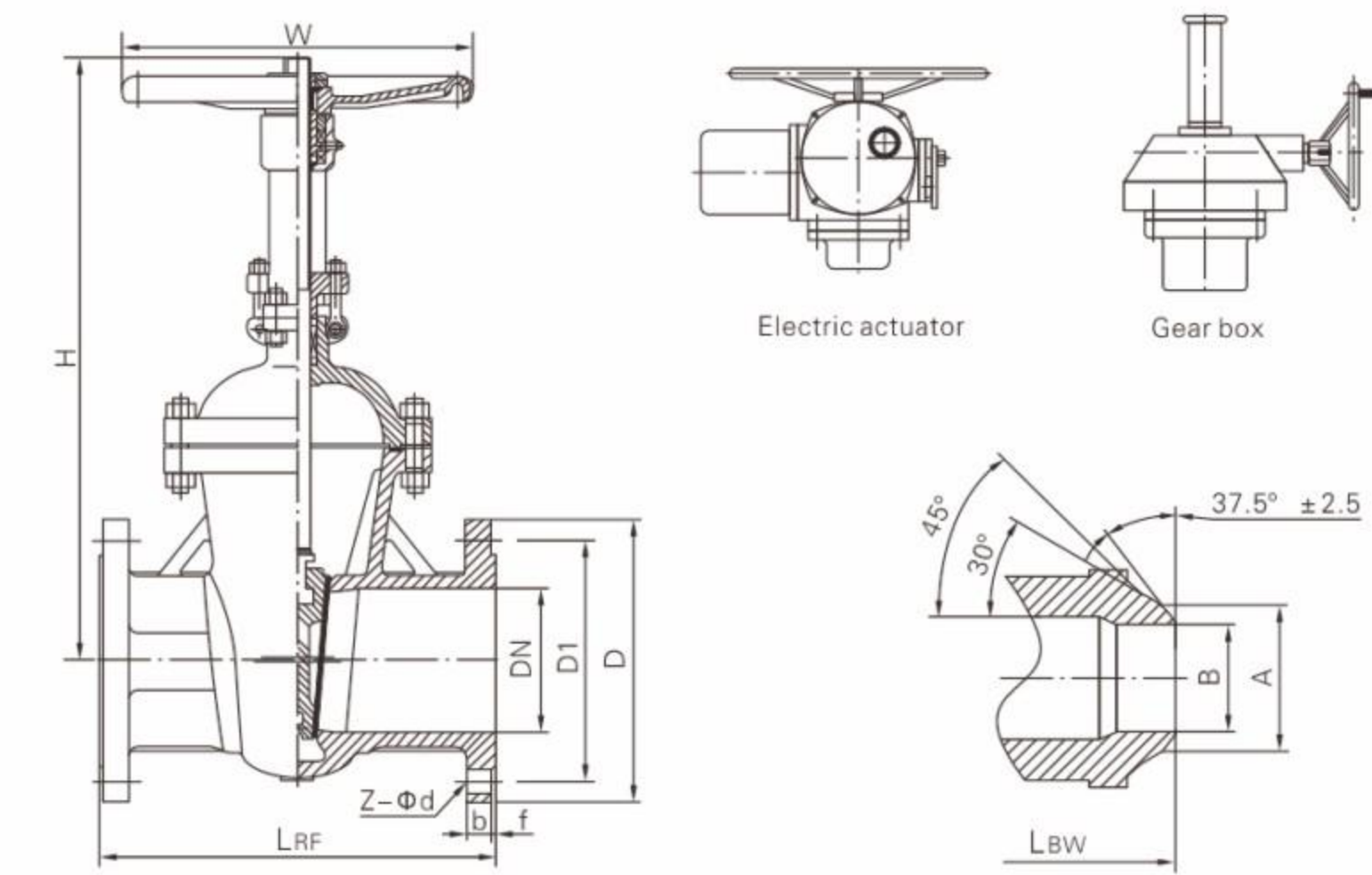

标准与规范 Standards and specifications

设计标准 Design standard	GOST 5762-2002
结构长度 Face to face	GOST 3706-93
法兰连接 Flanges connection	GOST 12815-80
对焊端连接 Welding connection	GB/T 12224
试验与检验 Testing standard	ISO5208 GOST 356-80
压力-温度等级 Pressure-Temp	GB/T 12224

性能规范 Performance specification

公称压力 (MPa) PN	壳体试验 (MPa) Shell test	密封试验 (MPa) Seal test	上密封 (MPa) Top seal test	气密封试验 (MPa) Air seal test
1.6	2.4	1.76	1.76	0.6
2.5	3.8	2.75	2.75	
4.0	6.0	4.4	4.4	
6.3	9.5	6.9	6.9	
10.0	15.0	11.0	11.0	
16.0	24.0	17.6	17.6	
20.0	30.0	22.0	22.0	

主要零件材料及性能 Main part materials and property

体、盖、瓣 Body Bonnet	阀杆 Stem	密封面 Seat	垫片 (环) Sealing shim	填料 Packing	工作温度(°C) Working temperature	适用介质 Suitable medium
25 L	2Cr13	13Cr	304+Flexible	Flexible	-196°C ~565°C	Water
20 GL						
Lc 1						STELLITE
CF 8	F304	316+Flexible	PTFE	Oil		
12Cr18Ni9Ti				F316		F304
CF8M	08 Soft Steel	F316	PTFE			
0Cr18Ni12Mo2Ti						

俄标闸阀 GOST gate valve

PN16 俄标闸阀

DN	LRF	L _{BW}	D	D ₁	b	Z-Φd	A	B	H	W
50	180	180	160	125	16	4-Φ18	60	50	355	200
65	190	190	180	145	20	4-Φ18	75	63	376	200
80	210	210	195	160	20	8-Φ18	91	78	435	280
100	230	230	215	180	20	8-Φ18	117	102	502	300
125	255	255	245	210	22	8-Φ18	144	128	615	320
150	280	280	280	240	22	8-Φ22	172	154	675	360
200	330	330	335	295	24	12-Φ22	223	203	820	400
250	450	450	405	355	26	12-Φ26	278	255	970	450
300	500	500	460	410	28	12-Φ26	329	305	1145	500
350	550	550	520	470	30	16-Φ26	362	337	1280	550
400	600	600	580	525	32	16-Φ30	413	387	1451	600
450	650	650	640	585	400	20-Φ30	464	438	1545	650
500	700	700	710	650	44	20-Φ33	516	489	1678	700
600	800	800	840	710	54	20-Φ36	619	591	1875	800
700	900	900	910	840	40	24-Φ36	721	695	2085	900
800	1000	1000	1020	950	42	24-Φ39	825	797	2405	950
900	1100	1100	1125	1050	44	28-Φ39	927	899	2950	1000
1000	1242	1242	1255	1170	46	28-Φ42	-	-	3244	1000

PN25 俄标闸阀

DN	L	D	D ₁	b	Z-Φd	A	B	H	W
50	250	160	125	20	4-Φ18	60	52	355	200
65	265	180	145	22	8-Φ18	75	63	376	200
80	280	195	160	24	8-Φ18	91	78	435	280
100	300	230	190	24	8-Φ22	117	102	502	300
125	325	270	220	26	8-Φ26	144	128	615	320
150	350	300	250	30	8-Φ26	172	154	675	360
200	400	360	310	34	12-Φ26	223	203	820	400
250	450	425	370	36	12-Φ30	278	255	970	450
300	500	485	430	36	16-Φ30	329	305	1145	500
350	550	550	490	38	16-Φ33	362	337	1280	550
400	600	610	550	40	16-Φ36	413	387	1451	600
450	650	670	600	46	20-Φ36	464	438	1545	650
500	700	730	660	48	20-Φ36	516	489	1678	700
600	800	840	770	58	20-Φ39	619	591	1875	800
700	900	960	875	50	24-Φ42	721	695	2085	900
800	1000	1085	990	54	24-Φ48	825	797	2405	950
900	1100	1185	1090	58	28-Φ48	927	899	2950	1000
1000	1242	1320	1210	62	28-Φ55	-	-	3244	1000

国标法兰闸阀 GB flange gate valve

结构优势与特点 Structural advantages and characteristics

- 符合国内外先进标准的要求，密封可靠，性能优良，造型美观。
 - 闸板、阀座密封面用铁基合金堆焊或司太立 (stellite) 钴基硬质合金堆焊而成，耐磨、耐高温、耐腐蚀、抗擦伤性能好、使用寿命长。
 - 采用楔式弹性闸板结构，中大口径设置滚动轴承，开关灵活，启闭轻松。
 - 阀杆经调质及表面氮化处理，有良好的抗腐蚀性，抗擦伤性和耐磨性。
 - 可采用各种配管法兰标准及法兰密封面型式，满足各种工程需要及用户要求。
 - 阀体材料品种齐全，填料、垫片可根据实际工况或用户要求合理选配，能适用于各种压力、温度及介质工况。
- Meets the domestic and foreign advanced standard requirement, the seal is reliable, the performance is fine, handsome appearance.
 - The damper plate, the valve seat packing surface is too vertical (stellite) with the iron-base alloy built-up welding or the department the cobalt base hard alloy built-up welding to become, wear-resisting, thermostable, anti-corrosive, the anti-abrasion performance is good, the service life is long.
 - Using wedge-type flexible gate structure, medium and large caliber set bearings, switches flexible, open and close easily.
 - Stem quenched and the nitrogen treatment, with good corrosion resistance, scratch resistance and wear resistance.
 - Can be used with a variety of standard pipe flanges and flange sealing surface types to meet various project needs and user requirements.
 - Valve body materials, variety, packing, gasket can be based on actual working conditions or the user requests a reasonable option, can be applied to all kinds of pressure, temperature and medium conditions.

标准与规范 Standards and norms

设计与制造 Design and Manufacture	结构长度 Structure Length	压力-温度等级 Pressure-temperature rating	连接法兰 Connection flange	试验与检验 Test and Inspection
GB 12234	GB 12221	GB/T 12224	JB/T 79.1-2-94 GB 9113-2009 HG 20592 ~ 20635	JB/T 9092-1999 GB 13927-2005

性能参数 Performance parameter

序号 No.	项目名称 Entry name	项目名称 Entry name					
		PN16	PN25	PN40	PN64	PN100	PN160
1	公称压力PN(MPa)	1.6	2.5	4.0	6.4	10	16
2	壳体强度试验压力 Shell strength test pressure(MPa)	常温下公称压力的1.5倍 1.5 Times the nominal pressure at room temperature					
3	高压密封试验压力 High-pressure sealing Test pressure(MPa)	常温下公称压力的1.1倍 1.1 Times the nominal pressure at room temperature					
4	常温下工作压力 Operating pressure at room temperature(MPa)	按GB/T 12224 压力温度额定值 According to GB/T 12224 pressure temperature rating					

主要零件材料 Main components material

名称 Name	材料 Material								
阀体/阀盖 Body/Bonnet	CF8	CF3	CF8M	CF3M	WCB	LCB	WC6	WC9	C5
闸板 Wedge	CF8	CF3	CF8M	CF3M	WCB	LCB	WC6	WC9	C5
阀杆 Stem	F304	F304L	F316	F316L	2CR13	F304	F304	F304	F304
阀杆螺母 Stem Nut	铝青铜 Aluminium Bronze								
填料 Packing	PTFE/柔性石墨				石墨 Graphite				
垫片 Gasket	PTFE/金属缠绕垫				石墨 Graphite				
压盖 Gland	CF8	CF3	CF8M	CF3M	WCB	LCB	WC6	WC9	C5
螺栓 Bolt	不锈钢 Stainless Steel				35CrMoA				
螺母 Nut	不锈钢 Stainless Steel				45、35CrMoA				
手轮 Handwheel	铸钢 Cast Steel								

国标法兰闸阀
GB flange gate valve

Z41W-10
16-25 C、I、P、R
63

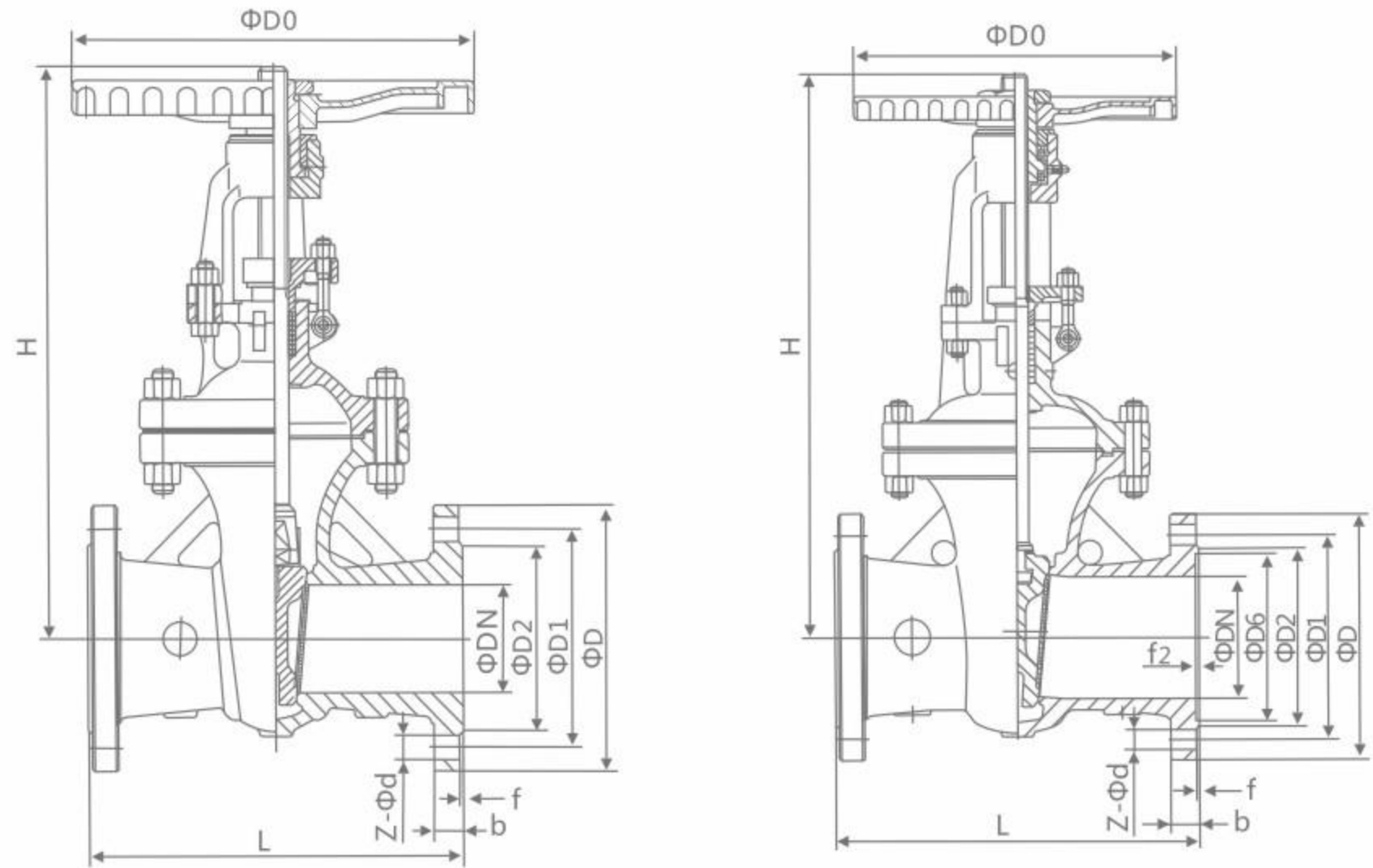

主要外形尺寸及连接尺寸 Main external and connection dimension

HG/T 20592

公称压力 PN(MPa)	公称口径 DN(mm)	尺寸 Size(mm)								电动装置型号 Electric device model	公称转矩 Nominal torqueNm	壁厚 Wall thickness	重量 Weight (Kg)
		L	D	D1	D2	b-f	Z-Φd	H	D0				
1.0	15	130	95	65	45	12-2	4-Φ14	160	100	-	-	-	-
	20	150	105	75	55	14-2	4-Φ14	165	100	-	-	-	-
	25	160	115	85	65	14-2	4-Φ14	200	125	-	-	-	-
	32	180	135	100	78	16-2	4-Φ18	240	125	-	-	-	-
	40	165	145	110	85	16-3	4-Φ18	245	135	DZW5A	50	-	-
	50	180	160	125	100	16-3	4-Φ18	286	180	DZW10A	100	-	-
	65	195	180	145	120	18-3	4-Φ18	320	180	DZW10A	100	-	-
	80	210	195	160	135	18-3	4-Φ18	373	200	DZW15A	150	-	-
	100	230	215	180	155	20-3	8-Φ18	428	200	DZW15A	150	-	-
	125	255	245	210	185	22-3	8-Φ18	513	240	DZW20A	200	-	-
	150	280	280	240	210	22-3	8-Φ23	582	240	DZW30A	300	-	-
	200	330	335	295	265	22-3	8-Φ23	730	320	DZW30A	300	-	-
	250	380	390	350	320	24-3	12-Φ23	897	320	DZW30A	450	-	-
	300	420	440	400	368	26-4	12-Φ23	1032	400	DZW45A	600	-	-
	350	450	500	460	428	26-4	16-Φ23	1170	400	DZW45A	900	-	-
	400	480	565	515	482	26-4	16-Φ25	1330	500	DZW60A	1200	-	-
	450	510	615	565	532	26-4	20-Φ25	1460	500	DZW90A	1800	-	-
	500	540	670	620	585	28-4	20-Φ25	1650	500	DZW120A	2500	-	-
	600	600	780	725	685	28-5	20-Φ30	183	600	DZW250A	2500	-	-
	700	660	895	840	800	30-5	24-Φ30	2120	700	DZW305A	3500	-	-
800	730	1010	950	905	32-5	24-Φ34	2420	800	DZW500A	5000	-	-	
900	800	1110	1050	1005	34-5	28-Φ34	2750	850	DZW800	8000	-	-	
1000	850	1220	1160	1115	34-5	28-Φ34	3130	900	DZW1000	10000	-	-	
1.6	15	130	95	65	45	16-2	4-Φ14	170	120	-	-	6.4	5
	20	150	105	75	55	18-2	4-Φ14	190	140	-	-	6.4	8
	25	160	115	85	65	18-2	4-Φ14	205	160	-	-	6.4	11
	32	180	140	100	78	18-2	4-Φ18	270	180	-	-	6.4	13
	40	200	150	110	85	18-3	4-Φ18	290	200	DZW10A	100	6.4	15
	50	250	165	125	100	18-3	4-Φ18	310	240	DZW10A	100	9.5	21
	65	265/270	185	145	120	18-3	8-Φ18	373	240	DZW15A	150	11	28
	80	280	200	160	135	20-3	8-Φ18	435	280	DZW20A	200	11.5	35
	100	300	220	180	155	20-3	8-Φ18	445	300	DZW20A	200	12.5	45
	125	325	250	210	185	22-3	8-Φ18	570	320	DZW30A	300	13	65
	150	350	285	240	210	22-3	8-Φ22	630	360	DZW30A	300	13.5	80
	200	400	340	295	265	24-3	12-Φ22	735	400	DZW30A	300	15	146
	250	450	405	355	320	26-3	12-Φ26	969	450	DZW45A	450	16	215
	300	500	460	410	375	28-4	12-Φ26	976	580	DZW60A	600	18	308
	350	550	520	470	435	30-4	16-Φ26	1120	640	DZW90	900	19	400
	400	600	580	525	485	32-4	16-Φ30	1452	640	DZW120	1200	21	452
	450	650	640	585	545	40-4	20-Φ30	1541	720	DZW180	1800	21.5	726
	500	700	715	650	608	44-4	20-Φ33	1880	720	DZW250	2500	22	995
	600	800	840	770	718	54-5	20-Φ36	1874	800	DZW250	2500	25	1370
	700	900	910	840	788	42-5	24-Φ36	2083	800	DZW350	3500	27	1650
800	1000	1025	950	898	42-5	24-Φ39	2400	850	DZW500	5000	30	2100	
900	1100	1125	1050	998	44-5	28-Φ39	2950	1000	DZW800	8000	30	3120	
1000	1200	1255	1170	1110	46-5	28-Φ42	3245	1000	DZW1000	10000	30	3950	

国标法兰闸阀
GB flange gate valve

主要外形尺寸及连接尺寸 Main external and connection dimension

HG/T 20592

公称压力 PN(MPa)	公称口径 DN(mm)	尺寸 Size(mm)								电动装置型号 Electric device model	公称转矩 Nominal torqueNm	壁厚 Wall thickness	重量 Weight (Kg)
		L	D	D1	D2	b-f	Z-Φd	H	D0				
2.5	15	130	95	65	45	16-2	4-Φ14	170	120	-	-	6.4	5
	20	150	105	75	55	18-2	4-Φ14	190	140	-	-	6.4	8
	25	160	115	85	65	18-2	4-Φ14	205	160	-	-	6.4	11
	32	180	140	100	78	18-2	4-Φ18	270	180	-	-	6.4	13
	40	200	150	110	85	18-3	4-Φ18	310	200	DZW10A	100	6.4	15
	50	250	165	125	100	20-3	4-Φ18	358	240	DZW10A	100	9.5	21
	65	265/270	185	145	120	22-3	8-Φ18	373	240	DZW15A	150	11	30
	80	280	200	160	135	24-3	8-Φ18	435	280	DZW20A	200	11.5	37
	100	300	235	190	160	24-3	8-Φ22	500	300	DZW20A	200	12.5	49
	125	325	270	220	188	26-3	8-Φ26	614	320	DZW30A	300	13	68
	150	350	300	250	218	28-3	8-Φ26	674	360	DZW30A	300	13.5	88
	200	400	360	310	278	30-3	12-Φ26	811	400	DZW30A	300	15	161
	250	450	425	370	332	32-3	12-Φ30	969	450	DZW45A	450	16	236
	300	500	485	430	390	34-4	16-Φ30	1145	580	DZW60A	600	18	342
	350	550	555	490	448	38-4	16-Φ33	1280	640	DZW90	900	19	438
	400	600	620	550	505	40-4	16-Φ36	1452	640	DZW120	1200	21	486
	450	650	670	600	555	46-4	20-Φ36	1541	720	DZW180	1800	21.5	763
	500	700	730	660	610	48-4	20-Φ36	1676	720	DZW250	2500	22	1080
	600	800	845	770	718	58-5	20-Φ39	1874	800	DZW250	2500	25	1470
	700	900	960	875	815	50-5	24-Φ42	2083	800	DZW350	3500	27	1750
800	1000	1085	990	930	54-5	24-Φ48	2400	950	DZW500	5000	30	2250	
900	1100	1185	1090	1025	58-5	28-Φ48	2950	1000	DZW800	8000	30	3270	
1000	1200	1320	1210	1140	62-5	28-Φ55	3245	1000	DZW1000	10000	30	4100	

主要外形尺寸及连接尺寸 Main external and connection dimension

HG/T 20592

公称压力 PN(MPa)	公称口径 DN(mm)	尺寸 Size(mm)										电动装置型号 Electric device model	公称转矩 Nominal torqueNm	壁厚 Wall thickness	重量 Weight (Kg)
		L	D	D1	D2	D6	b-f	f1	Z-Φd	H	D0				
4.0	15	130	95	65	45	40	16-2	4	4-Φ14	135	120	-	-	6.4	5
	20	150	105	75	55	51	18-2	4	4-Φ14	190	140	-	-	6.4	8
	25	160	115	85	65	58	18-2	4	4-Φ14	205	160	-	-	6.4	11
	32	180	140	100	78	66	18-2	4	4-Φ18	270	180	-	-	6.4	13
	40	200	150	110	85	76	18-3	4	4-Φ18	310	200	DZW10A	100	6.4	15
	50	250	165	125	100	88	20-3	4	4-Φ18	371	280	DZW10A	100	10	23
	65	280	185	145	120	110	22-3	4	8-Φ18	391	280	DZW15A	150	12	32
	80	310	200	160	135	121	24-3	4	8-Φ18	455	320	DZW20A	200	12.5	41
	100	350	235	190	160	150	24-3	4.5	8-Φ22	551	360	DZW20A	200	13.5	52
	125	400	270	220	188	176	26-3	4.5	8-Φ26	628	400	DZW20A	200	14	75
	150	450	300	250	218	204	28-3	4.5	8-Φ26	708	400	DZW30A	300	16	99
	200	550	375	320	282	260	34-3	4.5	12-Φ30	885	450	DZW45A	450	17	185
	250	650	450	385	345	313	38-3	4.5	12-Φ33	906	560	DZW60A	600	18.5	390
	300	750	515	450	408	364	42-4	4.5	16-Φ33	1203	640	DZW90	900	22	417
	350	850	580	510	465	422	46-4	5	16-Φ36	1341	640	DZW120	1200	25	495
	400	950	660	585	535	474	50-4	5	16-Φ39	1492	720	DZW180	1800	27	715
	500	1150	755	670	612	576	57-4	5	20-Φ42	1627	-	DZW250	2500	30	1773
	600	1350	890	795	730	678	72-5	6	20-Φ48	1925	-	DZW350	3500	32	2370
	700	1450	-	900	835	768	-	6	-	2310	-	DZW500	5000	35	2640
	800	1650	-	1030	960	876	-	6	-	2600	-	DZW800	8000	37	3239
6.3	15	170	105	75	55	40	20-2	4	4-Φ14	140	100	-	-	7.4	10
	20	190	130	90	68	51	22-2	4	4-Φ18	140	100	-	-	7.9	12
	25	210	140	100	78	58	24-2	4	4-Φ18	215	180	-	-	7.9	16
	32	230	155	110	82	66	26-2	4	4-Φ22	270	180	-	-	8.6	20
	40	240	170	125	95	76	28-3	4	4-Φ22	345	200	DZW10A	100	9.4	25
	50	250	180	135	105	88	26-3	4	4-Φ22	470	200	DZW15A	150	11	36
	65	280	205	160	130	110	26-3	4	8-Φ22	520	250	DZW20A	200	13	41
	80	310	215	170	140	121	28-3	4.							

国标法兰闸阀
GB flange gate valve

Z41 W - 100 C, I, P, R

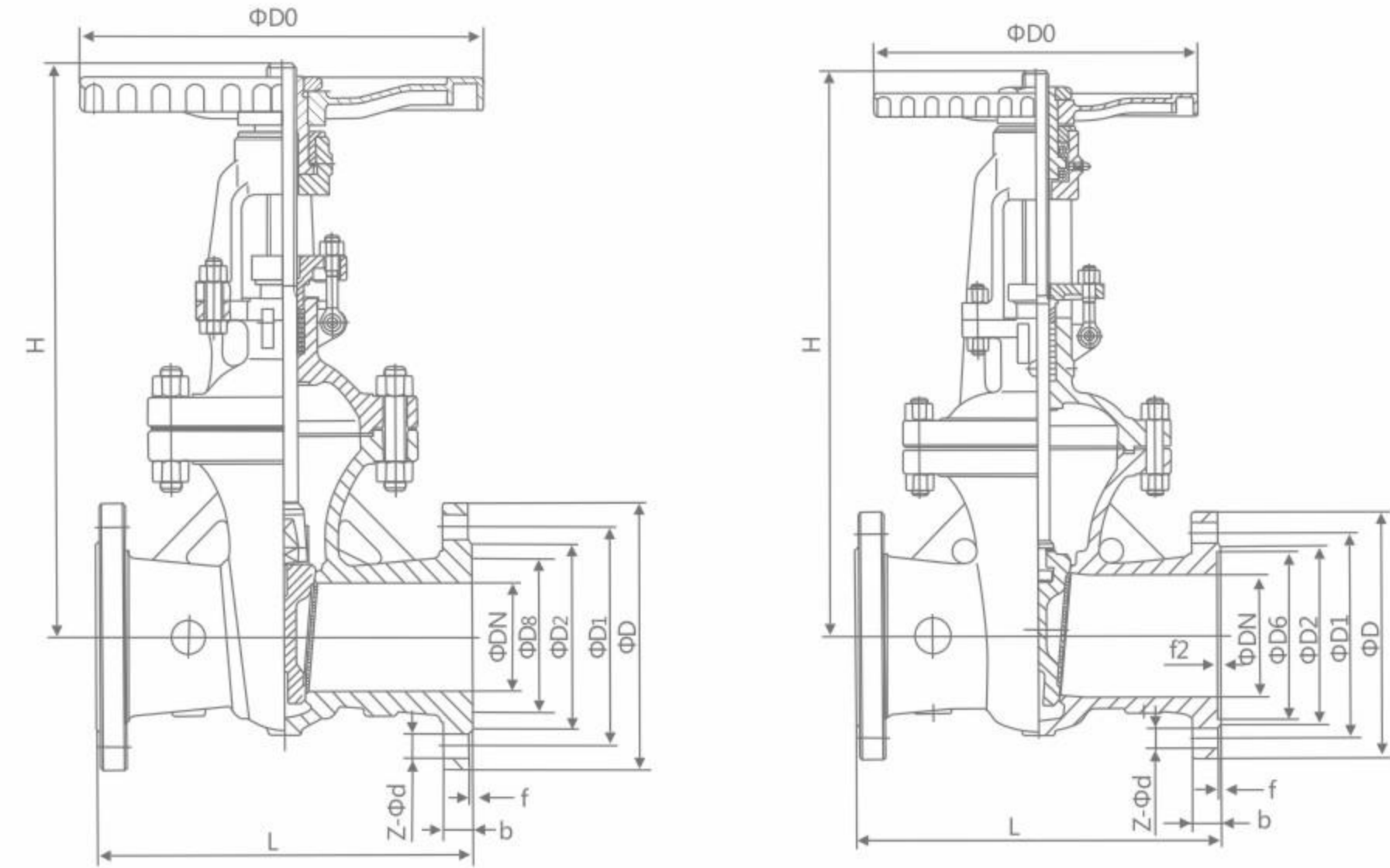

主要外形尺寸及连接尺寸 Main external and connection dimension

HG/T 20592

公称压力 PN(MPa)	公称通径 DN(mm)	尺寸 Size(mm)										电动装置型号 Electric device model	公称转矩 Nominal torque Nm	壁厚 Wall thickness	重量 Weight (kg)
		L	D	D1	D2	D8	D6	b	Z-Φd	H	D0				
10.0	15	170	105	75	55	35	40	20	4-Φ14	140	120	-	-	7.9	10
	20	190	130	90	68	45	51	22	4-Φ18	140	120	-	-	7.9	12
	25	210	140	100	78	50	58	24	4-Φ18	310	200	-	-	7.9	16
	32	230	155	110	82	65	66	26	4-Φ22	320	220	-	-	8.6	21
	40	240	170	125	95	75	76	28	4-Φ22	360	240	DZW15A	150	9.4	26
	50	250	190	145	112	85	88	30	4-Φ26	490	360	DZW20A	200	13	42
	65	280	220	170	138	110	110	34	8-Φ26	540	400	DZW20A	200	15	49
	80	310	230	180	148	115	121	36	8-Φ26	572	400	DZW30A	300	18	80
	100	350	265	210	172	145	150	40	8-Φ30	573	400	DZW45A	450	20	95
	125	400	315	250	210	175	176	40	8-Φ33	744	560	DZW60A	600	22	126
	150	450	355	290	250	205	204	44	12-Φ33	800	560	DZW90	900	28	192
	200	550	430	360	312	265	260	52	12-Φ36	800	560	DZW120	1200	30	260
	250	650	505	430	382	320	313	60	12-Φ39	1050	640	DZW180	1800	32	595
	300	750	585	500	442	375	364	68	16-Φ42	1200	720	DZW250	2500	35	810
	350	850	655	560	498	420	422	74	16-Φ48	1430	800	DZW350	3500	40	1310
	400	950	715	620	558	480	474	78	16-Φ48	1743	850	DZW500	5000	43	1668
500	1150	-	724	635	584	576	-	-	2055	900	DZW800	8000	50	2910	
16.0	15	170	105	75	52	35	40	20	4-Φ14	230	200	-	-	12.7	12
	20	190	130	90	62	45	51	24	4-Φ18	260	200	-	-	12.7	16
	25	210	140	100	72	50	58	24	4-Φ18	280	280	-	-	12.7	18
	32	230	155	115	85	65	66	28	4-Φ22	312	320	-	-	14.2	28
	40	260	170	125	92	75	76	28	4-Φ22	350	320	DZW15A	150	18	31
	50	300	195	165	132	95	88	30	4-Φ26	512	360	DZW20A	200	19	62
	65	340	220	190	152	110	110	34	8-Φ26	560	360	DZW30A	300	22	75
	80	390	230	205	168	130	121	36	8-Φ26	585	400	DZW30A	450	23	141
	100	450	265	240	200	160	150	40	8-Φ30	631	450	DZW45A	600	26	185
	125	525	315	285	238	190	176	44	8-Φ33	723	560	DZW60A	900	30	320
	150	600	355	318	270	205	204	50	12-Φ33	820	640	DZW90	1200	35	428
	200	750	430	400	345	275	260	60	12-Φ36	990	720	DZW120	1800	40	755
	250	838	515	485	425	330	313	68	12-Φ42	1120	800	DZW180	2500	42	1156
	300	965	585	570	510	380	364	78	12-Φ42	1300	850	DZW250	1500	48	1670



03

RUITONG VALVE

截止阀系列 GLOBE VALVE SERIES

美标截止阀 API Globe valve

J41 W-150Lb

产品概述 Products overview

美标截止阀主要有API和ASME标准, ASTM, ASTM是材料标准, 不是阀门本身的标准; 按美国标准设计, 制造, 生产、检测的截止阀叫做美标截止阀。

American standard cut-off valve mainly include API and ASME standard, ASTM, ASTM material standard, not the standard valve itself; According to the American standard design, manufacturing, production, testing, the cut-off valve American standard cut-off valve.

产品优点 Product advantages

1. 流体阻力小, 其阻力系数与同长度的管段相等。
 2. 结构简单、体积小、重量轻。
 3. 紧密可靠, 目前闸阀的密封面材料广泛使用塑料, 密封性好, 在真空系统中也已广泛使用。
 4. 操作方便, 开闭迅速, 从全开到全关只要旋转90°, 便于远距离的控制。
 5. 维修方便结构简单, 密封圈一般都是活动的, 拆卸更换都比较方便。
 6. 在全开或全闭时, 阀体和阀座的密封面与介质隔离, 介质通过时, 不会引起阀门密封面的侵蚀。
 7. 适用范围广, 口径从小到几毫米, 大到几米, 从高真空至高压力都可应用, 球旋转90度时, 在进出口处应全部呈现球面, 从而截断流动。
1. The fluid resistance is small, its resistance coefficient with section of equal length.
 2. Simple structure, small volume, light weight.
 3. Compact and reliable, the gate valve sealing surface of materials widely used plastic, sealing is good, have been widely used in the vacuum system.
 4. Easy to operate, open and close quickly, from open to close just rotate 90°, is advantageous for the remote control.
 5. Easy maintenance structure is simple, sealing ring, which generally remove replacement is more convenient.
 6. In the fully open or fully closed, the valve body and seat sealing surface and the dielectric isolation, medium through, does not cause the valve sealing surface erosion.
 7. Applicable scope is wide, size from small to several millimeters, big to a few meters, from high vacuum to high pressure can be applied, the ball rotate 90 degrees, in the inlet and outlet should be completely present spherical, thereby cutting flow.

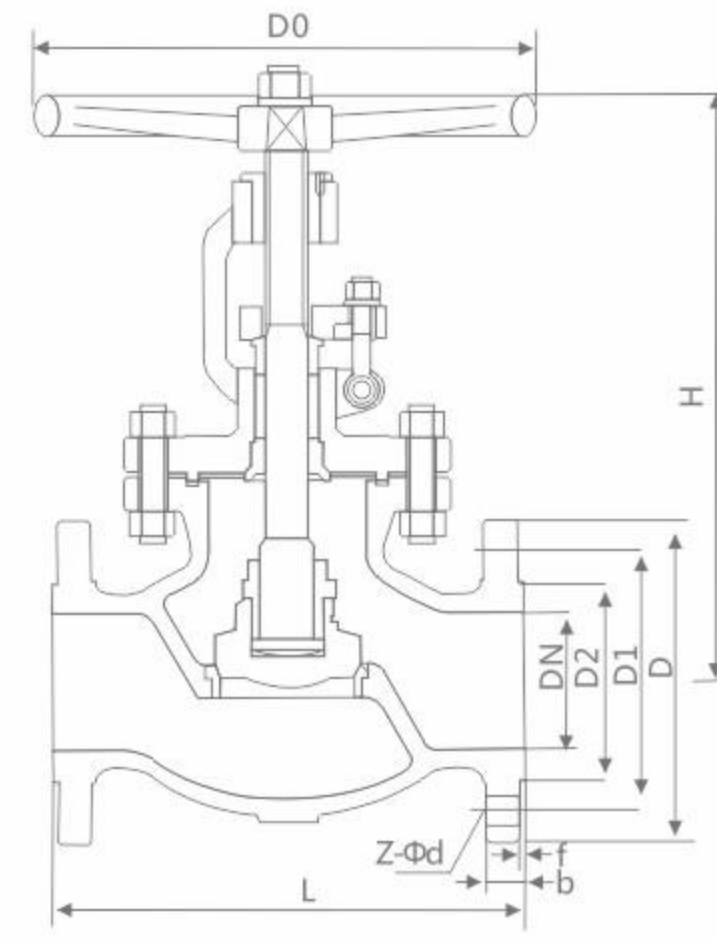

标准 Standard

设计与制造 Design and Manufacture	结构长度 Structure Length	法兰尺寸 Connection flange	对焊连接尺寸 Butt welding connection size	压力-温度 Pressure-temperature rating	试验-检验 Test and Inspection
ANSI B16.34 BS1873	ANSI B16.10	ANSI B16.5	ANSI B16.25	ANSI B16.34	API 598

压力试验 Pressure test

公称压力 PN(Lb)	强度试验 Strength test		水密封试验 Water sealing test		气密封试验 Air tightness test	
	MPa	Lbf/in2	MPa	Lbf/in2	MPa	Lbf/in2
150	3.0	430	2.2	315	0.4-0.7	60-100
300	7.7	1110	5.7	815		
600	15.3	2220	11.3	1630		
900	23.0	3330	17.0	2445		
1500	38.4	5560	28.2	4080		
2500	64.0	9255	47.0	6790		

主要零件材料及性能 Major parts material and the performance

体盖 Operculum corporis	阀杆 Valve stem	密封面 Sealing surface	垫片(环) Spacer (Ring)	填料 Filler	工作温度 Operation temperature	适用介质 Applicable Medium
WCB	2Cr13	CF8/13Cr/STL 本体材料/尼龙 CF8/13cr/STI body material/nylon	增强柔性石墨 13Cr/ 柔性石墨 SFB-2 08软钢 F304 F316 F304L F316L Reinforced flexible graphite 13C/ flexible graphite SFB-208 soft steel F304F316F304LF316L	柔性石墨 增强柔性石墨 Flexible graphite reinforced flexible graphite	≤ 425	水蒸汽油品 Water vapor oil
WC1	38CrMoAl				≤ 425	
WC6					≤ 540	
WC9					≤ 570	
C5 C12					≤ 540	
CF8					≤ 200	硝酸醋酸尿素 Urea nitrate acetate
CF8M	F316					
CF3	F304L					
CF3M	F316L					

注: 电动或齿轮传动, 价格另计。 Note: Electric or gear drive, the price extra.

美标截止阀 API Globe valve

主要尺寸和重量 Main dimensions and weight

DN		150Lb 凸面法兰 (RF) 主要尺寸 (mm)									重量
mm	in	L	D	D1	D2	b	N-Φd	H	D0		
15	1/2	108	89	60.5	35	11.2	4-16	241	100	6.9	
20	3/4	117	98	69.9	43	12.7	4-16	241	100	9.8	
25	1	127	108	79.2	51	14.2	4-16	242	125	13.5	
32	1 1/4	140	117	89	63	16	4-16	280	160	19.5	
40	1 1/2	165	127	98.6	73	17.5	4-16	286	160	28.5	
50	2	203	152	120.7	92	19	4-19	368	200	18	
65	2 1/2	216	178	139.7	105	22.4	4-19	387	200	30	
80	3	241	190	152.4	127	24	4-19	411	250	41	
100	4	292	229	190.5	157	24	4-19	454	250	64	
125	5	356	254	216.0	186	24	8-22.5	455	350	86	
150	6	406	279	241.3	216	25.4	8-22.5	541	350	113	
200	8	495	343	298.5	270	28.4	8-22.5	651	450	178	
250	10	622	406	362.0	324	30.2	12-25.4	800	450	270	
300	12	698	483	431.8	381	32	12-25.4	1231	600	350	
350	14	787	533	476.3	413	35	12-29	1450	600	460	
400	16	914	597	539.8	470	36.6	16-29	1645	600	590	

DN		300Lb 凸面法兰 (RF) 主要尺寸 (mm)									重量
mm	in	L	D	D1	D2	B	N-Φd	H	D0		
15	1/2	152	95	66.5	35	14.2	4-16	241	140	7.7	
20	3/4	178	117	82.5	43	16	4-19	241	140	11.3	
25	1	203	123	89	51	17.5	4-19	283	160	16.8	
32	1 1/4	216	133	98.5	63	19	4-19	320	200	21.2	
40	1 1/2	229	155	114.3	73	20.6	4-22.5	322	200	32.6	
50	2	267	165	127	92	22.4	8-19	399	200	25	
65	2 1/2	292	190	149.4	105	25.4	8-22.5	438	250	30	
80	3	318	210	168.1	127	28.4	8-22.5	464	280	35	
100	4	356	254	200.2	157	31.8	8-22.5	565	350	56	
125	5	400	279	235	186	35	8-22.5	614	350	96	
150	6	444	318	269.7	216	36.6	12-25.4	717	400	120	
200	8	559	381	330.2	270	41.2	12-25.4	930	500	212	
250	10	622	444	387.4	324	47.8	16-28.5	1012	550	330	
300	12	711	521	450.8	381	50.8	16-32	1231	600	472	
350	14	838	584	514.4	413	54	20-32	1450	600	715	
400	16	864	648	571.5	470	57.2	20-35	1645	600	920	

DN		600Lb 凸面法兰 (RF) 主要尺寸 (mm)									重量
mm	in	L	D	D1	D2	B	N-Φd	H	D0		
15	1/2	165	95	66.5	35	14.5	4-16	285	100	7.8	
20	3/4	190	117	82.5	43	16	4-19	285	125	12.5	
25	1	216	124	89	51	17.5	4-19	313	160	17.5	
32	1 1/4	229	133	98.5	63	21	4-19	328	160	23.5	
40	1 1/2	241	156	114.3	73	22.5	4-22.5	365	180	38.5	
50	2	292	165	127	92	33	8-19	444	200	35	
65	2 1/2	330	190	149.4	105	36	8-22.5	483	250	50	
80	3	356	210	168.1	127	39	8-22.5	533	250	60	
100	4	432	273	216	157	45	8-25.4	622	350	110	
125	5	508	330	266.7	186	52	8-28.5	750	350	200	
150	6	559	356	292.1	216	55	12-28.5	800	450	230	
200	8	660	419	349.3	270	63	12-32	927	500	410	
250	10	787	508	431.8	324	71	16-35	1257	600	625	
300	12	838	559	489	381	74	20-35	1468	680	860	

日标截止阀 JIS Globe valve

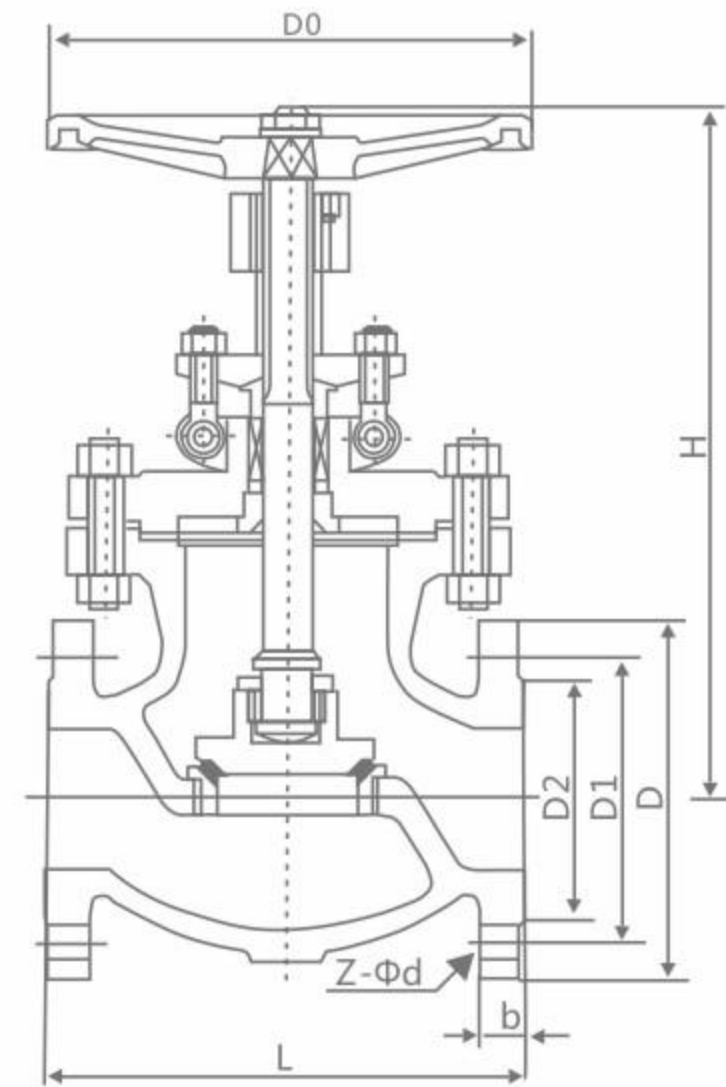

执行标准 Execution standard

设计与制造 Design and Manufacture	结构长度 Structure Length	法兰尺寸 Connection flange	压力-温度 Pressure-temperature rating	试验-检验 Test and Inspection
JIS B2071 B2081	JIS B2002	JIS B2212 B2214	JIS B2071 B2081	JIS B2003

性能规范 The performance specification

阀体材料 Valve body material	SCPH2-11	SCPH-32	SCS13A	SCS19A	SCS14A	SCS16A	SCPL1
适用温度 Applicable temperature	≤425°C	≤540°C	≤275°C	≤200°C	≤275°C	≤200°C	-45~-150°C
适用介质 Applicable Medium	水蒸气油品 Water vapor oil		硝酸类 Nitric Acid		醋酸类 Acetic acid		氨气液氨 Ammonia liquid ammonia

规格主要尺寸 Main size

DN		10K							
mm	Im	L	D	D1	D2	b	n-φd	H	D0
50	2	203	155	120	100	16	4-φ19	360	200
65	2 1/2	216	175	140	120	18	4-φ19	380	200
80	3	241	185	150	130	18	8-φ19	415	250
100	4	292	210	175	155	18	8-φ19	465	250
125	5	356	250	210	185	20	8-φ23	515	300
150	6	406	280	240	215	22	8-φ23	545	350
200	8	495	330	290	265	22	12-φ23	675	450
		20K							
50	2	267	155	120	100	18	8-φ19	420	200
65	2 1/2	292	175	140	120	20	8-φ19	465	250
80	3	318	200	160	135	22	8-φ23	490	300
100	4	356	225	185	160	24	8-φ23	590	350
125	5	400	270	225	195	26	8-φ25	690	400
150	6	444	305	260	230	28	12-φ25	760	450
200	8	559	350	305	275	30	12-φ25	1070	450

俄标截止阀 GOST Globe valve

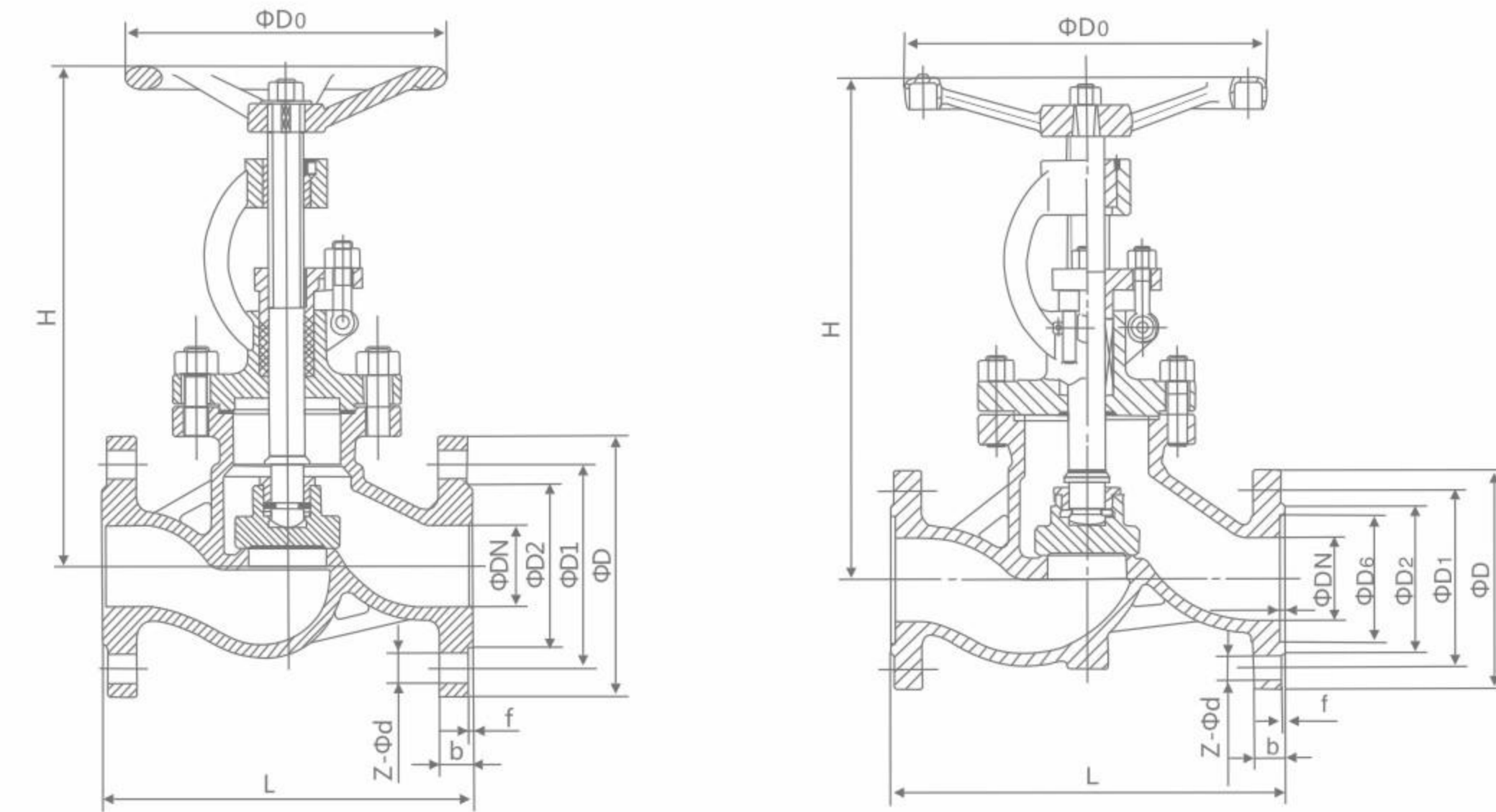

主要外形尺寸及连接尺寸 Main external and connection dimension

公称压力 PN(MPa)	公称口径 DN(mm)	尺寸Size(mm)										电动装置型号 Electric device model	壁厚 Wall thickness
		L	D	D1	D2	D6	b-f	f2	Z-φd	H	D0		
1.6	10	130	90	60	40	-	16-2	-	4-φ14	198	120	-	6.4
	15	130	95	65	45	-	16-2	-	4-φ14	218	120	-	6.4
	20	150	105	75	55	-	18-2	-	4-φ14	230	140	-	6.4
	25	160	115	85	65	-	18-2	-	4-φ14	240	160	-	6.4
	32	180	140	100	78	-	18-2	-	4-φ18	250	180	-	6.4
	40	200	150	110	85	-	18-3	-	4-φ18	262	200	-	6.4
	50	230	165	125	100	-	18-3	-	4-φ18	280	240	DZW10A	7.9
	65	290	185	145	120	-	18-3	-	8-φ18	327	280	DZW10A	11
	80	310	200	160	135	-	20-3	-	8-φ18	355	280	DZW10A	11.5
	100	350	220	180	155	-	20-3	-	8-φ18	415	320	DZW15A	12.5
	125	400	250	210	185	-	22-3	-	8-φ18	460	360	DZW20A	13
	150	480	285	240	210	-	22-3	-	8-φ22	510	400	DZW30A	13.5
	200	600	340	295	265	-	24-3	-	12-φ22	588	400	DZW45A	15
	250	650	405	355	320	-	26-3	-	12-φ26	725	450	DZW60A	16
	300	750	460	410	375	-	28-4	-	12-φ26	925	500	DZW90	18
	350	850	520	470	435	-	30-4	-	16-φ26	1030	600	DZW120	19
	400	950	580	525	485	-	32-4	-	16-φ30	1170	700	DZW180	21
	450	1050	640	585	545	-	40-4	-	20-φ30	1220	800	DZW180	21.5
	500	1150	715	650	608	-	44-4	-	20-φ33	1410	900	DZW250	22
	600	1350	840	770	718	-	54-5	-	20-φ36	1610	1000	DZW350	25

俄标截止阀 GOST Globe valve

主要外形尺寸及连接尺寸 Main external and connection dimension

公称压力 PN(MPa)	公称通径 DN(mm)	尺寸Size(mm)										电动装置型号 Electric device model	壁厚 Wall thickness
		L	D	D1	D2	D6	b-f	f2	Z-Φd	H	D0		
2.5	10	130	90	60	40	-	16-2	-	4-Φ14	198	120	-	6.4
	15	130	95	65	45	-	16-2	-	4-Φ14	218	120	-	6.4
	20	150	105	75	55	-	18-2	-	4-Φ14	258	140	-	6.4
	25	160	115	85	65	-	18-2	-	4-Φ14	275	160	-	6.4
	32	180	140	100	78	-	18-2	-	4-Φ18	280	180	-	6.4
	40	200	150	110	85	-	18-3	-	4-Φ18	330	200	-	6.4
	50	230	165	120	100	-	20-3	-	4-Φ18	350	240	DZW10A	7.9
	65	290	185	145	120	-	22-3	-	8-Φ18	400	280	DZW10A	11
	80	310	200	160	135	-	24-3	-	8-Φ18	355	280	DZW15A	11.5
	100	350	235	190	160	-	24-3	-	8-Φ22	415	320	DZW20A	12.5
	125	400	270	220	188	-	26-3	-	8-Φ26	460	360	DZW30A	13
	150	480	300	250	218	-	28-3	-	8-Φ26	510	400	DZW45A	13.5
	200	600	360	310	278	-	30-3	-	12-Φ26	710	400	DZW60A	15
	250	650	425	370	332	-	32-3	-	12-Φ30	786	450	DZW90	16
	300	750	485	430	390	-	34-4	-	16-Φ30	925	500	DZW120	18
	350	850	555	490	448	-	38-4	-	16-Φ33	1030	600	DZW180	19
400	950	620	550	405	-	40-4	-	16-Φ36	1170	700	DZW180	21	
450	1050	670	600	555	-	46-4	-	20-Φ36	1220	800	DZW250	21.5	
500	1150	730	660	610	-	48-4	-	20-Φ36	1450	900	DZW350	22	
600	1350	845	770	718	-	58-5	-	20-Φ39	1810	1000	DZW500	25	
4.0	10	130	90	60	40	35	16-2	4	4-Φ14	198	120	-	6.4
	15	130	95	65	45	40	16-2	4	4-Φ14	233	120	-	6.4
	20	150	105	75	55	51	18-2	4	4-Φ14	275	140	-	6.4
	25	160	115	85	65	58	18-2	4	4-Φ14	285	160	-	6.4
	32	180	140	100	78	66	18-2	4	4-Φ18	302	180	-	6.4
	40	200	150	110	85	76	18-3	4	4-Φ18	355	200	-	6.4
	50	230	165	125	100	88	20-3	4	4-Φ18	373	240	DZW10A	10
	65	290	185	145	120	110	22-3	4	8-Φ18	408	280	DZW10A	12
	80	310	200	160	135	121	24-3	4	8-Φ18	436	320	DZW20A	12.5
	100	350	235	190	160	150	24-3	4.5	8-Φ22	480	360	DZW30A	13.5
	125	400	270	220	188	176	26-3	4.5	8-Φ26	558	400	DZW45A	14
	150	480	300	250	218	204	28-3	4.5	8-Φ26	611	400	DZW60A	16
	200	600	375	320	282	260	34-3	4.5	12-Φ30	720	400	DZW90	17
	250	650	450	385	345	313	38-3	4.5	12-Φ33	665	500	DZW120	18.5
	300	750	515	450	408	364	42-4	4.5	16-Φ33	720	550	DZW180	22
	350	850	580	510	465	422	46-4	5	16-Φ36	860	600	DZW180	25
400	950	660	585	535	474	50-4	5	16-Φ39	1010	700	DZW250	27	
450	1050	685	610	560	524	37-4	5	20-Φ39	1190	800	DZW300	29	
500	1150	755	670	612	576	57-4	5	20-Φ42	1260	900	DZW500	30	
6.3	10	170	100	70	50	35	20-2	4	4-Φ14	198	120	-	7.9
	15	170	105	75	55	40	20-2	4	4-Φ14	195	140	-	7.9
	20	190	130	90	68	51	22-2	4	4-Φ18	228	160	-	7.9
	25	210	140	100	78	58	24-2	4	4-Φ18	275	180	-	7.9
	32	230	155	110	82	66	26-2	4	4-Φ22	325	200	-	8.6
	40	260	170	125	95	76	28-3	4	4-Φ22	360	240	-	9.4
	50	300	180	135	105	88	26-3	4	4-Φ22	410	280	DZW10A	11
	65	340	205	160	130	110	26-3	4	8-Φ22	450	320	DZW15A	13
	80	380	215	170	140	121	28-3	4	8-Φ22	485	360	DZW30A	14
	100	430	250	200	168	150	30-3	4.5	8-Φ26	537	400	DZW45A	15
	125	500	295	240	202	176	34-3	4.5	8-Φ30	631	400	DZW60A	15.5
	150	550	345	280	240	204	36-3	4.5	8-Φ33	646	450	DZW90	18
	200	650	415	345	300	260	42-3	4.5	12-Φ36	813	500	DZW120	21
	250	775	470	400	352	313	46-3	4.5	12-Φ36	985	550	DZW180	23
	300	900	530	460	412	364	52-4	4.5	16-Φ36	1214	600	DZW250	25
	350	1025	600	525	475	422	56-4	5	16-Φ39	1432	650	-	28
400	1150	670	585	525	474	60-4	5	16-Φ42	1650	700	-	30	

注：电动或齿轮传动，价格另计。 Note: Electric or gear drive, the price extra.

国标截止阀 GB Globe valve

结构优势与特点 Structural advantages and characteristics

1. 产品设计制造按国家标准GB 12235,结构合理,密封可靠,性能优良,造型美观。
 2. 阀瓣、阀座密封面用铁基合金堆焊或司太立(stellite)钴基硬质合金堆焊而成,耐磨、耐高温、耐腐蚀、抗擦伤性能好、使用寿命长。
 3. 阀杆经调质及表面氮化处理,有良好的抗腐蚀性和抗擦伤性。
 4. 可采用各种配管法兰标准及法兰密封面型式,满足各种工程需要和用户要求。
 5. 阀体材料品种齐全,填料、垫片可根据实际工况或用户要求合理选配,能适用与各种压力、温度及介质工况。
 6. 倒密封采用螺纹连接密封座或本体堆焊不锈钢而成,密封可靠,填料更换可在不停机情况下进行方便快捷不影响系统运行。
1. The product designed and manufactured according to national standard GB 12235, reasonable structure, reliable sealing, excellent performance and beautiful shape.
 2. Flap valve, the valve seat sealing surface of iron based alloy or stellite (stellite) made of cobalt-based alloy welding, wear-resistant, high temperature, corrosion, anti-abrasion performance, long life.
 3. Stem quenched and the nitrogen treatment, with good resistance to corrosion and scratch resistance.
 4. Can be used with a variety of standard pipe flanges and flange sealing surface types to meet various project needs and user requirements.
 5. Body material variety, packing, gasket can be based on actual working conditions or the user requests a reasonable option, can be applied with all kinds of pressure, temperature and medium conditions.
 6. Sealed with screw connection seal back seat or body made of stainless steel welding, sealing and reliable replacement of filling in non-stop convenient and efficient manner does not affect system operation.

标准与规范 Standards and norms

设计与制造 Design and Manufacture	结构长度 Structure Length	压力、温度等级 Pressure、 temperature rating	连接法兰 Connecting flange	检验与试验 Test and Inspection
GB 12235	GB 12221	GB 12224	JB/T 79/82~1994 GB 9113 HG 20592-20635	JB/T 9092-1999 GB 13927

主要零件材料 Main components material

名称 Name	材料 Material								
阀体/阀盖 Body/Bonnet	CF8	CF3	CF8M	CF3M	WCB	LCB	WC6	WC9	C5
阀瓣 Wedge	CF8	CF3	CF8M	CF3M	WCB	LCB	WC6	WC9	C5
阀杆 Stem	F304	F304L	F316	F316L	2CR13	F304	F304	F304	F304
阀杆螺母 Stem Nut	铝青铜 Aluminium Bronze								
填料 Packing	PTFE/柔性石墨				石墨 Graphite				
垫片 Gasket	PTFE/金属缠绕垫				石墨 Graphite				
压盖 Gland	CF8	CF3	CF8M	CF3M	WCB	LCB	WC6	WC9	C5
螺栓 Bolt	35CrMoA								
螺母 Nut	不锈钢 Stainless Steel				45、35CrMoA				
手轮 Handwheel	不锈钢 Stainless Steel				铸钢 Cast Steel				

国标截止阀
GB Globe valve

J41 W - 1.6
C, I, P, R

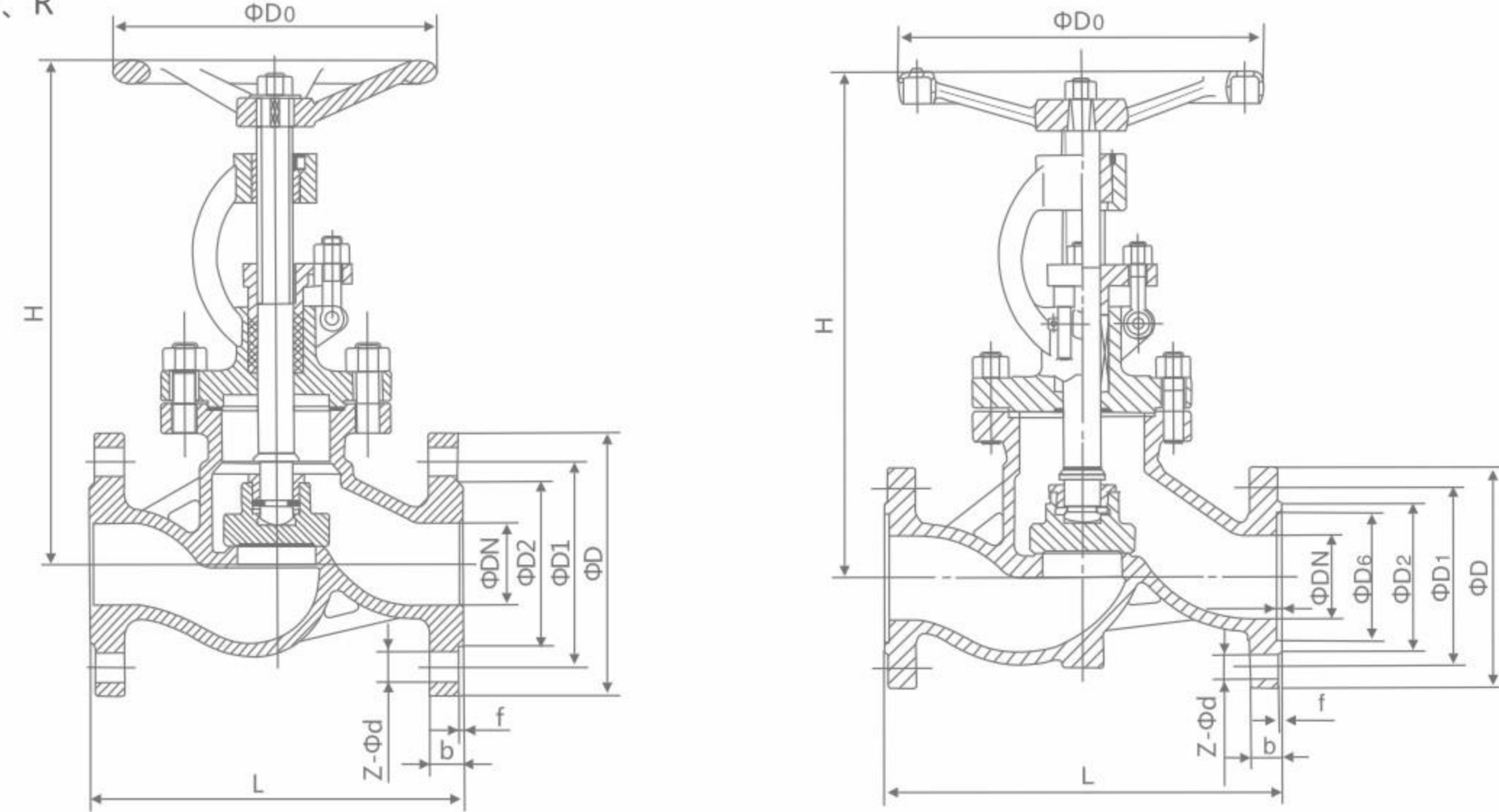

主要外形尺寸及连接尺寸 Main external and connection dimension

HG/T 20592

公称压力 PN(MPa)	公称口径 DN(mm)	尺寸Size(mm)										电动装置型号 Electric device model	壁厚 Wall thickness
		L	D	D1	D2	D6	b-f	f2	Z-Φd	H	D0		
1.6	10	130	90	60	40	-	16-2	-	4-Φ14	198	120	-	6.4
	15	130	95	65	45	-	16-2	-	4-Φ14	218	120	-	6.4
	20	150	105	75	55	-	18-2	-	4-Φ14	230	140	-	6.4
	25	160	115	85	65	-	18-2	-	4-Φ14	240	160	-	6.4
	32	180	140	100	78	-	18-2	-	4-Φ18	250	180	-	6.4
	40	200	150	110	85	-	18-3	-	4-Φ18	262	200	-	6.4
	50	230	165	125	100	-	18-3	-	4-Φ18	280	240	DZW10A	7.9
	65	290	185	145	120	-	18-3	-	8-Φ18	327	280	DZW10A	11
	80	310	200	160	135	-	20-3	-	8-Φ18	355	280	DZW10A	11.5
	100	350	220	180	155	-	20-3	-	8-Φ18	415	320	DZW15A	12.5
	125	400	250	210	185	-	22-3	-	8-Φ18	460	360	DZW20A	13
	150	480	285	240	210	-	22-3	-	8-Φ22	510	400	DZW30A	13.5
	200	600	340	295	265	-	24-3	-	12-Φ22	588	400	DZW45A	15
	250	650	405	355	320	-	26-3	-	12-Φ26	725	450	DZW60A	16
	300	750	460	410	375	-	28-4	-	12-Φ26	925	500	DZW90	18
	350	850	520	470	435	-	30-4	-	16-Φ26	1030	600	DZW120	19
	400	950	580	525	485	-	32-4	-	16-Φ30	1170	700	DZW180	21
	450	1050	640	585	545	-	40-4	-	20-Φ30	1220	800	DZW180	21.5
500	1150	715	650	608	-	44-4	-	20-Φ33	1410	900	DZW250	22	
600	1350	840	770	718	-	54-5	-	20-Φ36	1610	1000	DZW350	25	

国标截止阀
GB Globe valve

主要外形尺寸及连接尺寸 Main external and connection dimension

HG/T 20592

公称压力 PN(MPa)	公称口径 DN(mm)	尺寸Size(mm)										电动装置型号 Electric device model	壁厚 Wall thickness
		L	D	D1	D2	D6	b-f	f2	Z-Φd	H	D0		
2.5	10	130	90	60	40	-	16-2	-	4-Φ14	198	120	-	6.4
	15	130	95	65	45	-	16-2	-	4-Φ14	218	120	-	6.4
	20	150	105	75	55	-	18-2	-	4-Φ14	258	140	-	6.4
	25	160	115	85	65	-	18-2	-	4-Φ14	275	160	-	6.4
	32	180	140	100	78	-	18-2	-	4-Φ18	280	180	-	6.4
	40	200	150	110	85	-	18-3	-	4-Φ18	330	200	-	6.4
	50	230	165	120	100	-	20-3	-	4-Φ18	350	240	DZW10A	7.9
	65	290	185	145	120	-	22-3	-	8-Φ18	400	280	DZW10A	11
	80	310	200	160	135	-	24-3	-	8-Φ18	355	280	DZW15A	11.5
	100	350	235	190	160	-	24-3	-	8-Φ22	415	320	DZW20A	12.5
	125	400	270	220	188	-	26-3	-	8-Φ26	460	360	DZW30A	13
	150	480	300	250	218	-	28-3	-	8-Φ26	510	400	DZW45A	13.5
	200	600	360	310	278	-	30-3	-	12-Φ26	710	400	DZW60A	15
	250	650	425	370	332	-	32-3	-	12-Φ30	786	450	DZW90	16
	300	750	485	430	390	-	34-4	-	16-Φ30	925	500	DZW120	18
	350	850	555	490	448	-	38-4	-	16-Φ33	1030	600	DZW180	19
	400	950	620	550	505	-	40-4	-	16-Φ36	1170	700	DZW180	21
	450	1050	670	600	555	-	46-4	-	20-Φ36	1220	800	DZW250	21.5
500	1150	730	660	610	-	48-4	-	20-Φ36	1450	900	DZW350	22	
600	1350	845	770	718	-	58-5	-	20-Φ39	1810	1000	DZW500	25	
4.0	10	130	90	60	40	35	16-2	4	4-Φ14	198	120	-	6.4
	15	130	95	65	45	40	16-2	4	4-Φ14	233	120	-	6.4
	20	150	105	75	55	51	18-2	4	4-Φ14	275	140	-	6.4
	25	160	115	85	65	58	18-2	4	4-Φ14	285	160	-	6.4
	32	180	140	100	78	66	18-2	4	4-Φ18	302	180	-	6.4
	40	200	150	110	85	76	18-3	4	4-Φ18	355	200	-	6.4
	50	230	165	125	100	88	20-3	4	4-Φ18	373	240	DZW10A	10
	65	290	185	145	120	110	22-3	4	8-Φ18	408	280	DZW10A	12
	80	310	200	160	135	121	24-3	4	8-Φ18	436	320	DZW20A	12.5
	100	350	235	190	160	150	24-3	4.5	8-Φ22	480	360	DZW30A	13.5
	125	400	270	220	188	176	26-3	4.5	8-Φ26	558	400	DZW45A	14
	150	480	300	250	218	204	28-3	4.5	8-Φ26	611	400	DZW60A	16
	200	600	375	320	282	260	34-3	4.5	12-Φ30	720	400	DZW90	17
	250	650	450	385	345	313	38-3	4.5	12-Φ33	665	500	DZW120	18.5
	300	750	515	450	408	364	42-4	4.5	16-Φ33	720	550	DZW180	22
	350	850	580	510	465	422	46-4	5	16-Φ36	860	600	DZW180	25
	400	950	660	585	535	474	50-4	5	16-Φ39	1010	700	DZW250	27
	450	1050	685	610	560	524	37-4	5	20-Φ39	1190	800	DZW300	29
500	1150	755	670	612	576	57-4	5	20-Φ42	1260	900	DZW500	30	

注：电动或齿轮传动，价格另计。 Note: Electric or gear drive, the price extra.

国标截止阀
GB Globe valve

J41 W - 63
Y - 10.0 C, I, P, R
16.0

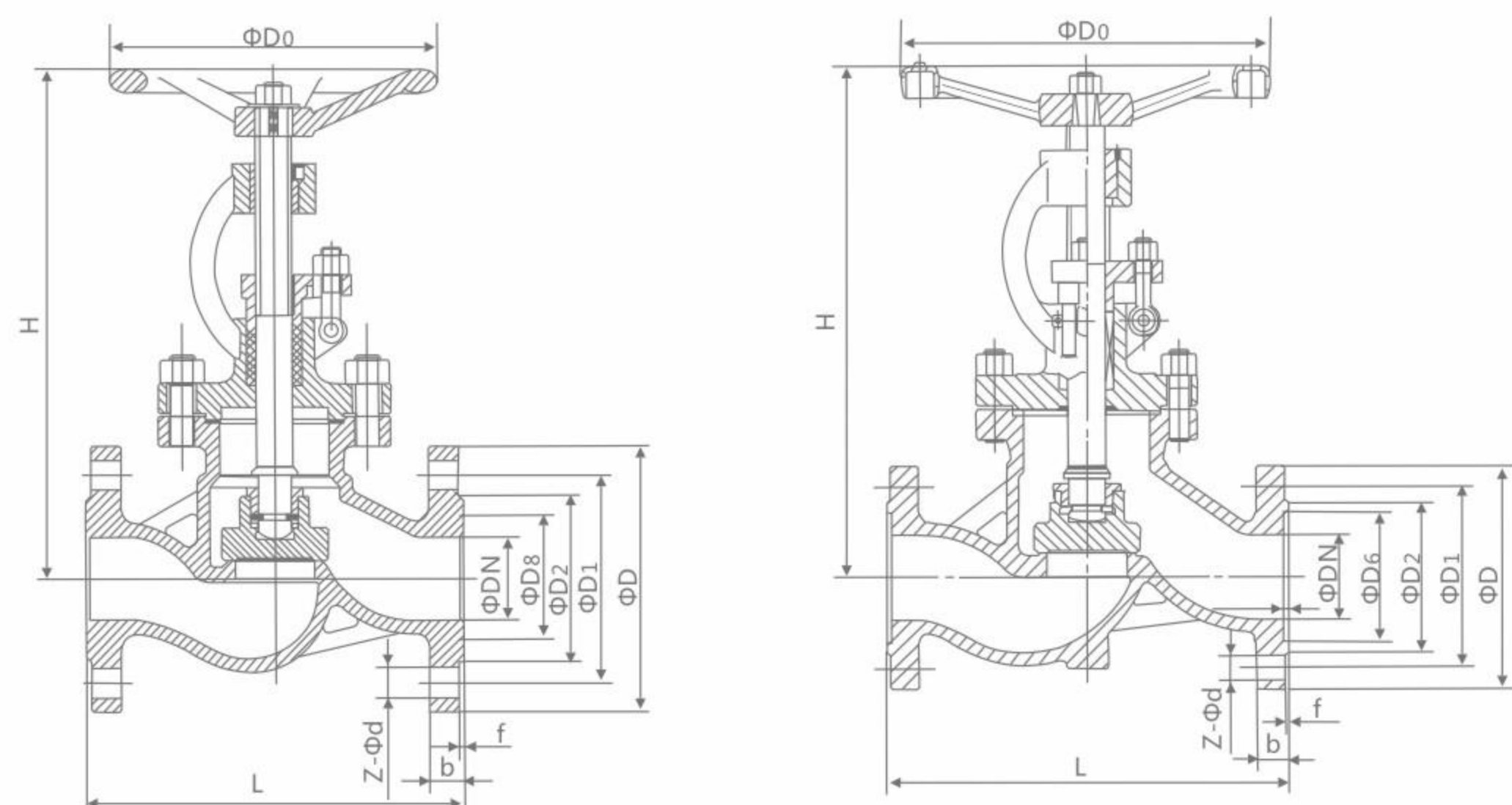

主要外形尺寸及连接尺寸 Main external and connection dimension

HG/T 20592

公称压力 PN(MPa)	公称口径 DN(mm)	尺寸Size(mm)											电动装置型号 Electric device model	壁厚 Wall thickness
		L	D	D1	D2	D6	D8	b-f	f2	Z-φd	H	D0		
6.3	10	170	100	70	50	35	-	20-2	4	4-Φ14	198	120	-	7.9
	15	170	105	75	55	40	-	20-2	4	4-Φ14	195	140	-	7.9
	20	190	130	90	68	51	-	22-2	4	4-Φ18	228	160	-	7.9
	25	210	140	100	78	58	-	24-2	4	4-Φ18	275	180	-	7.9
	32	230	155	110	82	66	-	26-2	4	4-Φ22	325	200	-	8.6
	40	260	170	125	95	76	-	28-3	4	4-Φ22	360	240	-	9.4
	50	300	180	135	105	88	-	26-3	4	4-Φ22	410	280	DZW10A	11
	65	340	205	160	130	110	-	26-3	4	8-Φ22	450	320	DZW15A	13
	80	380	215	170	140	121	-	28-3	4	8-Φ22	485	360	DZW30A	14
	100	430	250	200	168	150	-	30-3	4.5	8-Φ26	537	400	DZW45A	15
	125	500	295	240	202	176	-	34-3	4.5	8-Φ30	631	400	DZW60A	15.5
	150	550	345	280	240	204	-	36-3	4.5	8-Φ33	646	450	DZW90	18
	200	650	415	345	300	260	-	42-3	4.5	12-Φ36	813	500	DZW120	21
	250	775	470	400	352	313	-	46-3	4.5	12-Φ36	985	550	DZW180	23
	300	900	530	460	412	364	-	52-4	4.5	16-Φ36	1214	600	DZW250	25
	350	1025	600	525	475	422	-	56-4	5	16-Φ39	1432	650	-	28
400	1150	670	585	525	474	-	60-4	5	16-Φ42	1650	700	-	30	
10.0	10	170	100	70	50	-	35	20-2	-	4-Φ14	198	120	-	7.9
	15	170	105	75	55	-	45	20-2	-	4-Φ14	202	140	-	7.9
	20	190	130	90	68	-	50	22-2	-	4-Φ18	228	160	-	7.9
	25	210	140	100	78	-	65	24-2	-	4-Φ18	250	180	-	7.9
	32	230	155	110	82	-	75	26-2	-	4-Φ22	326	220	-	8.6
	40	260	170	125	95	-	85	28-3	-	4-Φ22	359	240	-	9.4
	50	300	190	145	112	-	110	30-3	-	4-Φ26	414	280	DZW20A	13
	65	340	220	170	138	-	115	34-3	-	8-Φ26	434	320	DZW30A	14
	80	380	230	180	148	-	145	36-3	-	8-Φ26	547	400	DZW45A	18
	100	430	265	210	172	-	145	40-3	-	8-Φ30	621	450	DZW60A	20
	125	500	315	250	210	-	175	40-3	-	8-Φ33	732	450	DZW90	22
	150	550	355	290	250	-	205	44-3	-	12-Φ33	840	500	DZW120	28
	200	650	430	360	312	-	265	52-3	-	12-Φ36	925	550	DZW180	30
	250	775	505	430	382	-	320	60-3	-	12-Φ39	1155	600	DZW250	32
	300	900	585	500	442	-	375	68-4	-	16-Φ42	1340	700	DZW300	35
	16.0	15	170	105	75	52	-	35	20-2	-	4-Φ14	148	140	-
20		190	130	90	62	-	45	24-2	-	4-Φ18	156	160	-	12.7
25		210	140	100	72	-	50	24-2	-	4-Φ18	125	180	-	12.7
32		230	155	115	85	-	65	28-2	-	4-Φ22	200	200	-	14.2
40		260	170	125	92	-	75	28-3	-	4-Φ22	231	240	-	18
50		300	195	165	132	-	95	30-3	-	4-Φ26	262	250	DZW30A	19
65		340	220	190	152	-	110	34-3	-	8-Φ26	303	320	DZW45A	22
80		380	230	205	168	-	130	36-3	-	8-Φ26	341	400	DZW90	23
100		430	265	240	200	-	160	40-3	-	8-Φ30	485	450	DZW120	26
150		550	355	318	270	-	190	50-3	-	12-Φ33	630	550	DZW250	35
200	650	430	400	345	-	205	60-3	-	12-Φ36	775	700	DZW350	40	

注：电动或齿轮传动，价格另计。 Note: Electric or gear drive, the price extra.



04

RUITONG VALVE

止回阀系列 CHECK VALVE SERIES

美标旋启式止回阀 API Swing check valve

概述 Overview

我公司生产的美标止回阀，完全按照美国标准设计制造，结构美观、先进。美标止回阀是指依靠介质本身流动而自动开、闭阀瓣，用来防止介质倒流的阀门，又称逆止阀、单向阀、逆流阀。止回阀属于一种自动阀门，其主要作用是防止介质倒流、防止泵及驱动电动机反转，以及容器介质的泄放。

性能参数 Performance parameter

序号	项目名称	项目名称					
		150(Lb)	300(Lb)	600(Lb)	900(Lb)	1500(Lb)	2500(Lb)
1	公称压力PN (MPa)	2.0	5.0	10.0	15.0	25.0	42.0
2	壳体强度试验压力 Shell strength test pressure (MPa)	常温下公称压力的1.5倍 1.5 Times the nominal pressure at room temperature					
3	高压密封试验压力 High-pressure sealing test pressure (MPa)	常温下工作压力的1.1倍 1.1Times the nominal pressure at room temperature					
4	常温下工作压力 Nominal pressure at room temperature (MPa)	按ASME B16.34 压力温度额定值 According to ASME B16.34 pressure temperature rating					

产品规范 Product specification

设计标准 Design	结构长度 Structure Length	法兰连接尺寸 Connection flange	试验与检验 Test and Inspection	压力与温度基准 ASME B16.34
BS1868/API6D ASME B16.34	ASME B16.10	ASME B16.5 ASME B16.47A系列	API 598/API 6D	ASME B16.34

主要零件材料 Main components material

零件名称 Part Name	材料名称 Material name					
阀体Body	A216 WCB	A217 WC6	A351 CF8	A351 CF8M	A351 CF3	A351 CF3M
阀盖 Valve cover	A216 WCB	A217 WC6	A351 CF8	A351 CF8M	A351 CF3	A351 CF3M
阀板 valve plate	A216 WCB	A217 WC6	A351 CF8	A351 CF8M	A351 CF3	A351 CF3M
密封面 sealing face	13Cr/STL	STL	本体/STL	本体/STL	本体/STL	本体/STL
阀轴	A182 F6a	A182 F11	A182 F304	A182 F316	A182 F304L	A182 F316L
垫片	304+柔性石墨/软铁	304+柔性石墨/F304	304+柔性石墨/F304	316+柔性石墨/F316	304L+柔性石墨/F304L	316L+柔性石墨/F316L
螺栓	A193 B7	A193 B16	A193 B8	A193 B8M	A193 B8	A193 B8M
螺母	A194 2H	A194 4	A194 8	A194 8M	A194 8	A194 8M
使用温度	-29~425°C	-29~540°C	-46~425°C	-46~425°C	-46~425°C	-46~425°C
适用介质	水、蒸汽、油品等	水、蒸汽等	硝酸类弱腐蚀介质	硝酸类弱腐蚀介质	硝酸类弱腐蚀介质	硝酸类弱腐蚀介质

美标旋启式止回阀 API Swing check valve

H44 W-150Lb

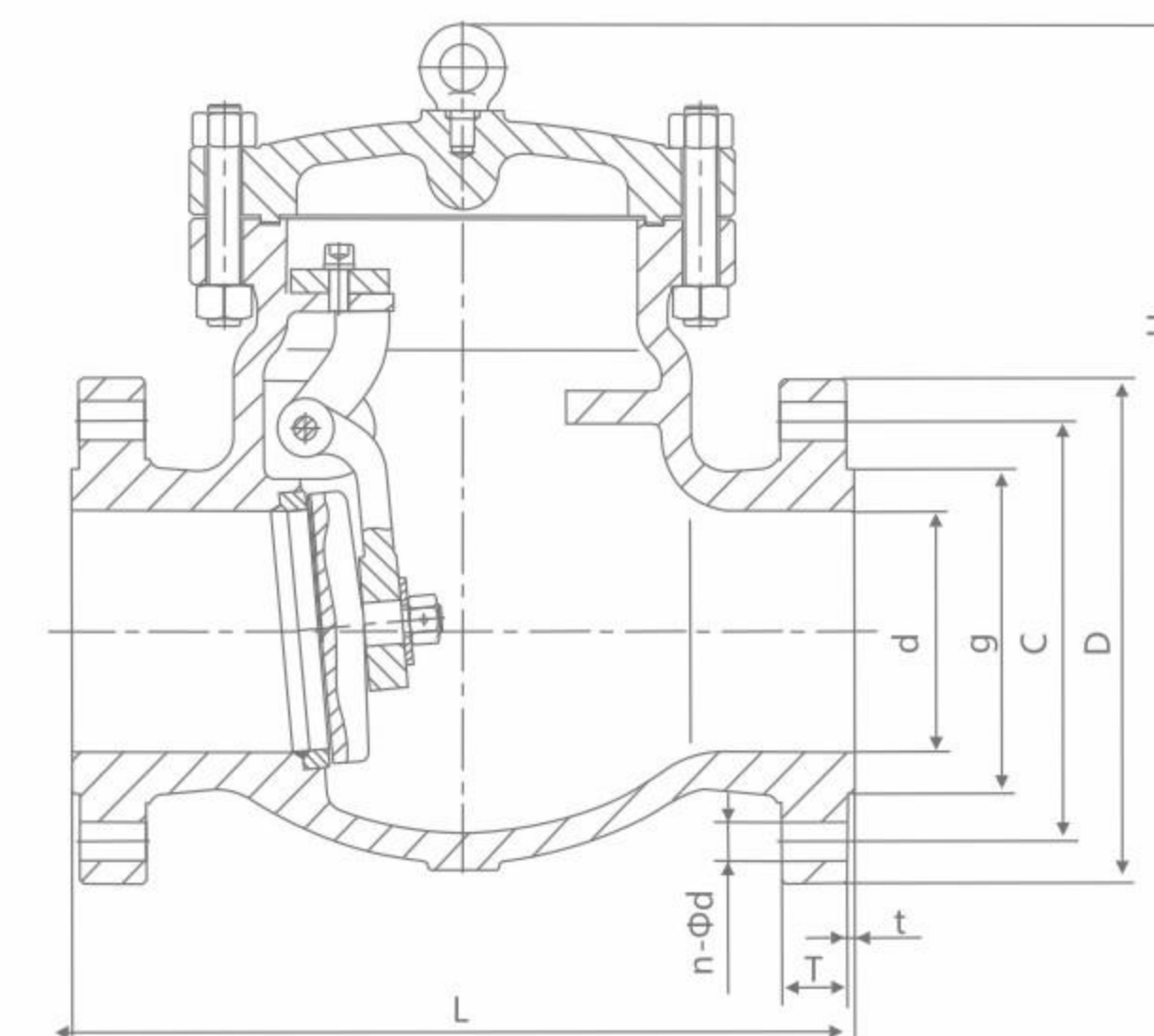

主要尺寸 Dimensions of Flanged end

公称压力 Nominal pressure	Dimensions(mm)									
	in	d	L	D	C	g	T	t	H	n-Φ
Class 150Lb	1/2"	15	108	89	60.5	35	12	1.6	-	4-15
	3/4"	20	117	98	70.0	43	12	1.6	-	4-15
	1"	25	127	108	79.5	51	12	1.6	-	4-15
	1-1/4"	32	140	117	89	64	13	1.6	-	4-15
	1-1/2"	40	165	127	98.5	73	15	1.6	-	4-15
	2"	50	203	152	120.5	92	16	1.6	161	4-19
	2-1/2"	65	216	178	139.5	105	18	1.6	180	4-19
	3"	80	241	190	152.5	127	19	1.6	190	4-19
	4"	100	292	229	190.5	157	24	1.6	203	8-19
	5"	125	330	254	216	186	24	1.6	229	8-22
	6"	150	356	279	241.5	216	26	1.6	257	8-22
	8"	200	495	343	298.5	270	29	1.6	292	8-22
	10"	250	622	406	362	324	31	1.6	355	12-25
	12"	300	698	483	432	381	32	1.6	396	12-25
	14"	350	787	533	476	413	35	1.6	445	12-29
	16"	400	864	597	540	470	37	1.6	490	16-29
18"	450	978	635	578	533	40	1.6	520	16-32	
20"	500	978	698	635	584	43	1.6	546	20-32	
24"	600	1295	813	749.5	692	49	1.6	880	20-35	
26"	650	1295	786	744.5	711	41	1.6	910	36-22	
28"	700	1448	837	795.5	762	44	1.6	935	40-22	
30"	750	1524	887	846.0	813	44	1.6	970	44-22	

美标旋启式止回阀 API Swing check valve

主要尺寸 Dimensions of Flanged end

公称压力 Nominal pressure	Dimensions(mm)									
	in	d	L	D	C	g	T	t	H	n-Φ
Class 300Lb	1/2"	15	152	95	66.5	35	15	1.6	-	4-15
	3/4"	20	178	117	82.5	43	16	1.6	-	4-19
	1"	25	203	124	89	51	18	1.6	-	4-19
	1-1/4"	32	216	133	98.5	63	19	1.6	-	4-19
	1-1/2"	40	229	156	114.5	73	21	1.6	-	4-22
	2"	50	267	165	127	92	22	1.6	178	8-19
	2-1/2"	65	292	190	149	105	25	1.6	190	8-22
	3"	80	318	210	168	127	29	1.6	216	8-22
	4"	100	356	254	200	157	32	1.6	241	8-22
	5"	125	400	279	235	186	35	1.6	267	8-22
	6"	150	444	318	270	216	37	1.6	305	12-22
	8"	200	533	381	330	270	41	1.6	368	12-25
	10"	250	622	444	387.5	324	48	1.6	394	16-29
	12"	300	711	521	451	381	51	1.6	445	16-32
	14"	350	838	584	514.5	413	54	1.6	470	20-32
	16"	400	864	648	571.5	470	57	1.6	533	20-35
18"	450	978	711	628.5	533	60	1.6	584	24-35	
20"	500	1016	775	686	584	64	1.6	610	24-35	
24"	600	1346	914	813	692	70	1.6	900	24-41	
Class 600Lb	2"	50	292	165	127	92	33	6.4	203	8-19
	2-1/2"	65	330	190	149	105	36	6.4	229	8-22
	3"	80	356	210	168	127	39	6.4	235	8-22
	4"	100	432	273	216	157	45	6.4	286	8-25
	5"	125	508	330	266.5	186	52	6.4	292	8-29
	6"	150	559	356	292	216	55	6.4	330	12-29
	8"	200	660	419	349	270	63	6.4	381	12-32
	10"	250	787	508	432	324	71	6.4	457	16-35
	12"	300	838	559	489	381	74	6.4	584	20-35
	14"	350	889	603	527	413	77	6.4	635	20-38
	16"	400	991	686	603	470	84	6.4	684	20-41
	18"	450	1092	743	654	533	90	6.4	752	20-44
20"	500	1194	813	724	584	96	6.4	975	24-44	

日标旋启式止回阀 JIS Swing check valve

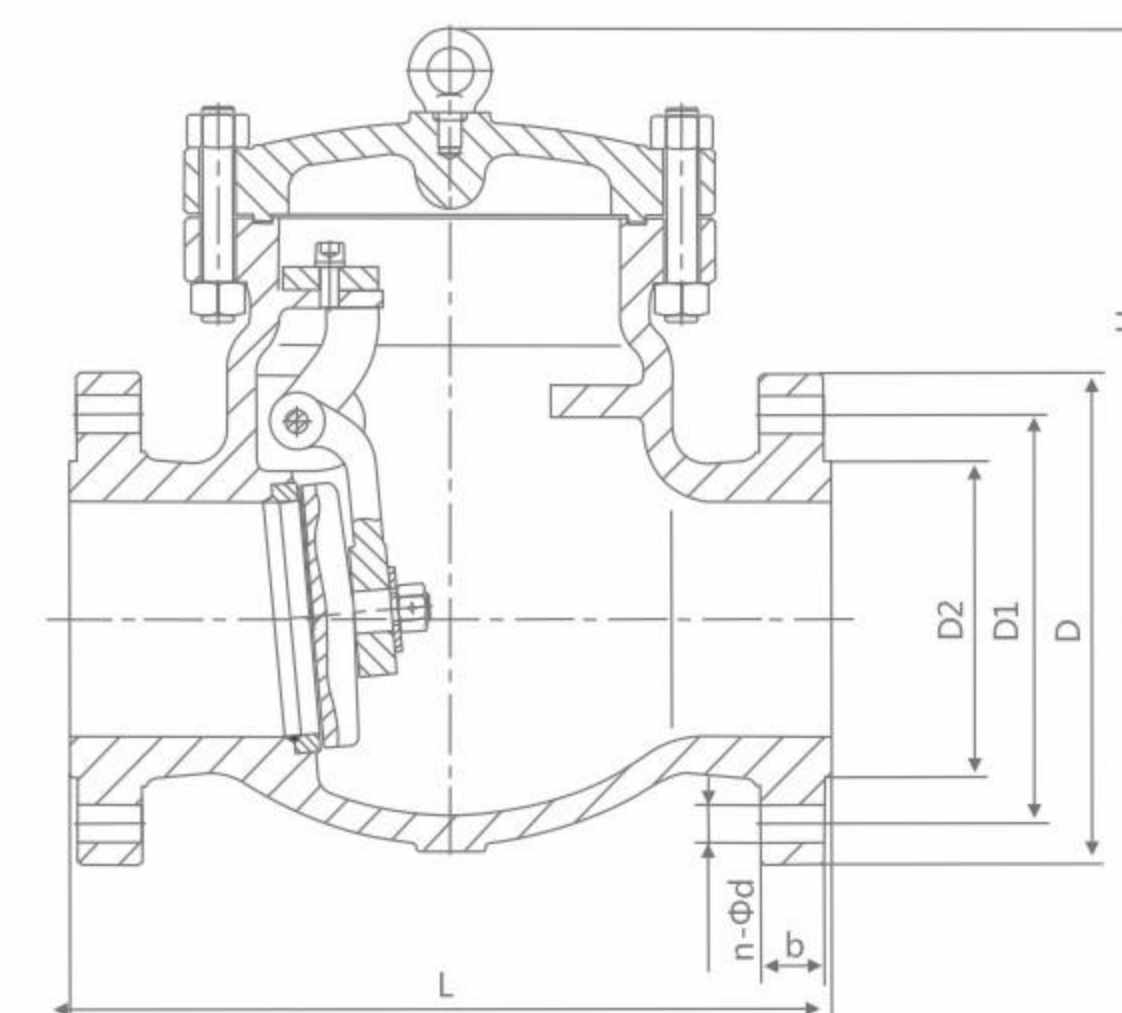

产品规范 Product specification

设计标准 Design	结构长度 Structure Length	法兰连接尺寸 Connection flange	压力-温度 Pressure-temperature	试验与检验 Test and Inspection
JIS B2074 B2084	JIS B2002	JIS B2212 B2214	JIS B2074 B2084	JIS B2003

主要尺寸 Dimensions of Flanged end

DN		10K						
mm	in	L	D	D1	D2	b	n-Φd	H
50	2"	203	155	120	100	16	4-19	165
65	2 1/2"	216	175	140	120	18	4-19	175
80	3"	241	185	150	130	18	8-19	190
100	4"	292	210	175	155	18	8-19	215
150	6"	406	280	240	215	22	8-23	265
200	8"	495	330	290	265	22	12-23	320
250	10"	622	400	355	325	24	12-25	365
300	12"	698	445	400	370	24	16-25	415
350	14"	787	490	445	415	26	16-25	460

俄标旋启式止回阀
GOST Swing check valve

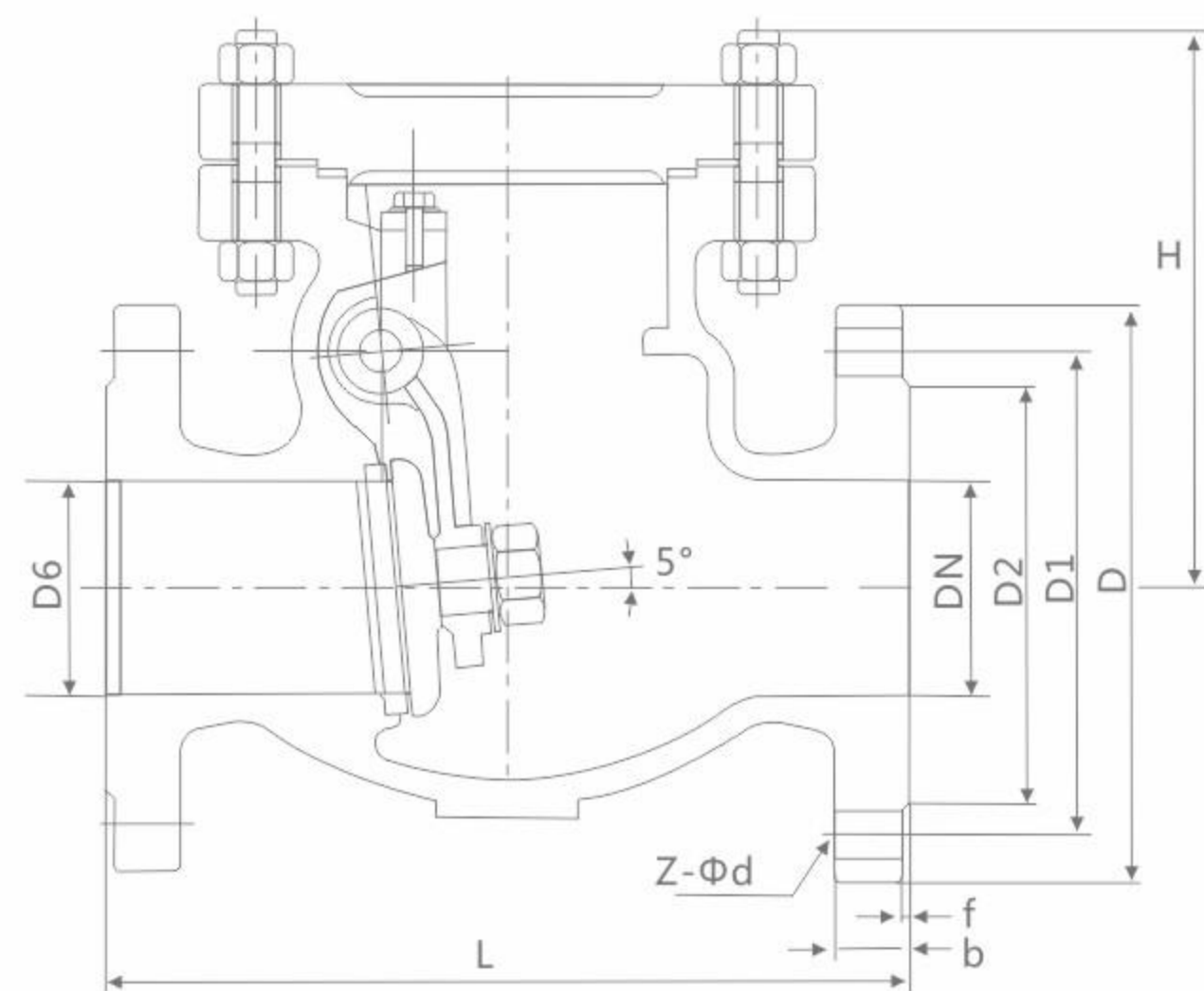

主要连接尺寸 Main Connection Dimensions

型号 Type	公称通径 DN(mm)	尺寸 Dimension(mm)									壁厚 Wall thickness	重量 (kg)
		L	D	D1	D2	D6	b-f	F2	z-φd	H		
16	20	150	105	75	55	-	18-2	-	4-φ14	100	6.4	5
	25	160	115	85	65	-	18-2	-	4-φ14	100	6.4	8
	32	180	140	100	78	-	18-2	-	4-φ18	105	6.4	11
	40	200	150	110	85	-	18-3	-	4-φ18	115	6.4	13
	50	230	165	125	100	-	18-3	-	4-φ18	135	7.9	25
	65	290	185	145	120	-	18-3	-	8-φ18	140	11	28
	80	310	200	160	135	-	20-3	-	8-φ18	145	11.5	34
	100	350	220	180	155	-	20-3	-	8-φ18	165	12.5	42
	125	400	250	210	185	-	22-3	-	8-φ18	250	13	60
	150	480	285	240	210	-	22-3	-	8-φ22	295	13.5	75
	200	550	340	295	265	-	24-3	-	12-φ22	315	15	145
	250	650	405	355	320	-	26-3	-	12-φ26	430	16	228
	300	750	460	410	375	-	28-4	-	12-φ26	480	18	330
	350	850	520	470	435	-	30-4	-	16-φ26	500	20	415
	400	950	580	525	485	-	32-4	-	16-φ30	520	21	600
	450	1050	640	585	545	-	40-4	-	20-φ30	580	22	802
500	1150	715	650	608	-	44-4	-	20-φ33	630	24	1010	
600	1350	840	770	718	-	54-5	-	20-φ36	780	26	1558	

主要连接尺寸 Main Connection Dimensions

型号 Type	公称通径 DN(mm)	尺寸 Dimension(mm)									壁厚 Wall thickness	重量 (kg)
		L	D	D1	D2	D6	b-f	F2	z-φd	H		
25	20	150	105	75	55	-	18-2	-	4-φ14	100	6.4	-
	25	160	115	85	65	-	18-2	-	4-φ14	100	6.4	-
	32	180	140	100	78	-	18-2	-	4-φ18	105	6.4	-
	40	200	150	110	85	-	18-3	-	4-φ18	115	6.4	-
	50	230	165	125	100	-	20-3	-	4-φ18	135	7.9	21
	65	290	185	145	120	-	22-3	-	8-φ18	140	11	30
	80	310	200	160	135	-	24-3	-	8-φ18	145	11.5	37
	100	350	235	190	160	-	24-3	-	8-φ22	165	12.5	49
	125	400	270	220	188	-	26-3	-	8-φ26	250	13	68
	150	480	300	250	218	-	28-3	-	8-φ26	295	13.5	88
	200	550	360	310	278	-	30-3	-	12-φ26	315	15	160
	250	650	425	370	332	-	32-3	-	12-φ30	430	16	243
	300	750	485	430	390	-	34-4	-	16-φ30	480	18	360
	350	850	555	490	448	-	38-4	-	16-φ33	500	20	450
	400	950	620	550	505	-	40-4	-	16-φ36	520	21	640
	450	1050	670	600	555	-	46-4	-	20-φ36	580	22	840
500	1150	730	660	610	-	48-4	-	20-φ36	630	24	1070	
600	1350	845	770	718	-	58-5	-	20-φ39	780	26	1650	
40	20	150	105	75	55	51	18-2	-	4-φ14	100	6.4	-
	25	160	115	85	65	58	18-2	-	4-φ14	100	6.4	-
	32	180	140	100	78	66	18-2	-	4-φ18	105	6.4	-
	40	200	150	110	85	76	18-3	-	4-φ18	115	6.4	-
	50	230	165	125	100	88	20-3	-	4-φ18	135	10	23
	65	290	185	145	120	110	22-3	-	8-φ18	140	12	32
	80	310	200	160	135	121	24-3	-	8-φ18	145	12.5	41
	100	350	235	190	160	150	24-3	-	8-φ22	165	13.5	52
	125	400	270	220	188	176	26-3	-	8-φ26	250	14	75
	150	480	300	250	218	204	28-3	-	8-φ26	295	16	99
	200	550	375	320	282	260	34-3	-	12-φ30	315	17	185
	250	650	450	385	345	313	38-3	-	12-φ33	430	18.5	390
	300	750	515	450	408	364	42-4	-	16-φ33	480	22	430
	350	850	580	510	465	422	46-4	-	16-φ36	500	24	525
	400	950	660	585	535	474	50-4	-	16-φ39	520	25	890
	450	1050	685	610	560	524	37-4	-	20-φ39	580	26	950
500	1150	755	670	612	576	57-4	-	20-φ42	630	30	1300	
600	1350	890	795	730	678	72-5	-	20-φ48	780	32	1690	
63	50	300	180	135	105	88	26-3	4	4-φ22	192	11	36
	65	340	205	160	130	110	26-3	4	8-φ22	207	13	41
	80	380	215	170	140	121	28-3	4	8-φ22	207	14	48
	100	430	250	200	168	150	30-3	4.5	8-φ26	235	15	76
	125	500	295	240	202	176	34-3	4.5	8-φ30	265	15.5	89
	150	550	345	280	240	204	36-3	4.5	8-φ33	297	18	140
	200	650	415	345	300	260	42-3	4.5	12-φ36	357	21	208
	250	775	470	400	352	313	46-3	4.5	12-φ36	405	23	492
	300	900	530	460	412	364	52-4	4.5	16-φ36	465	25	560
	350	1025	600	525	475	422	56-4	5	16-φ39	514	28	870
	400	1150	700	585	525	474	60-4	5	16-φ42	568	30	1085
	500	1400	-	705	640	576	-	5	-	620	35	2080

国标旋启式止回阀 GB Swing check valve

H44W-16C/P/R

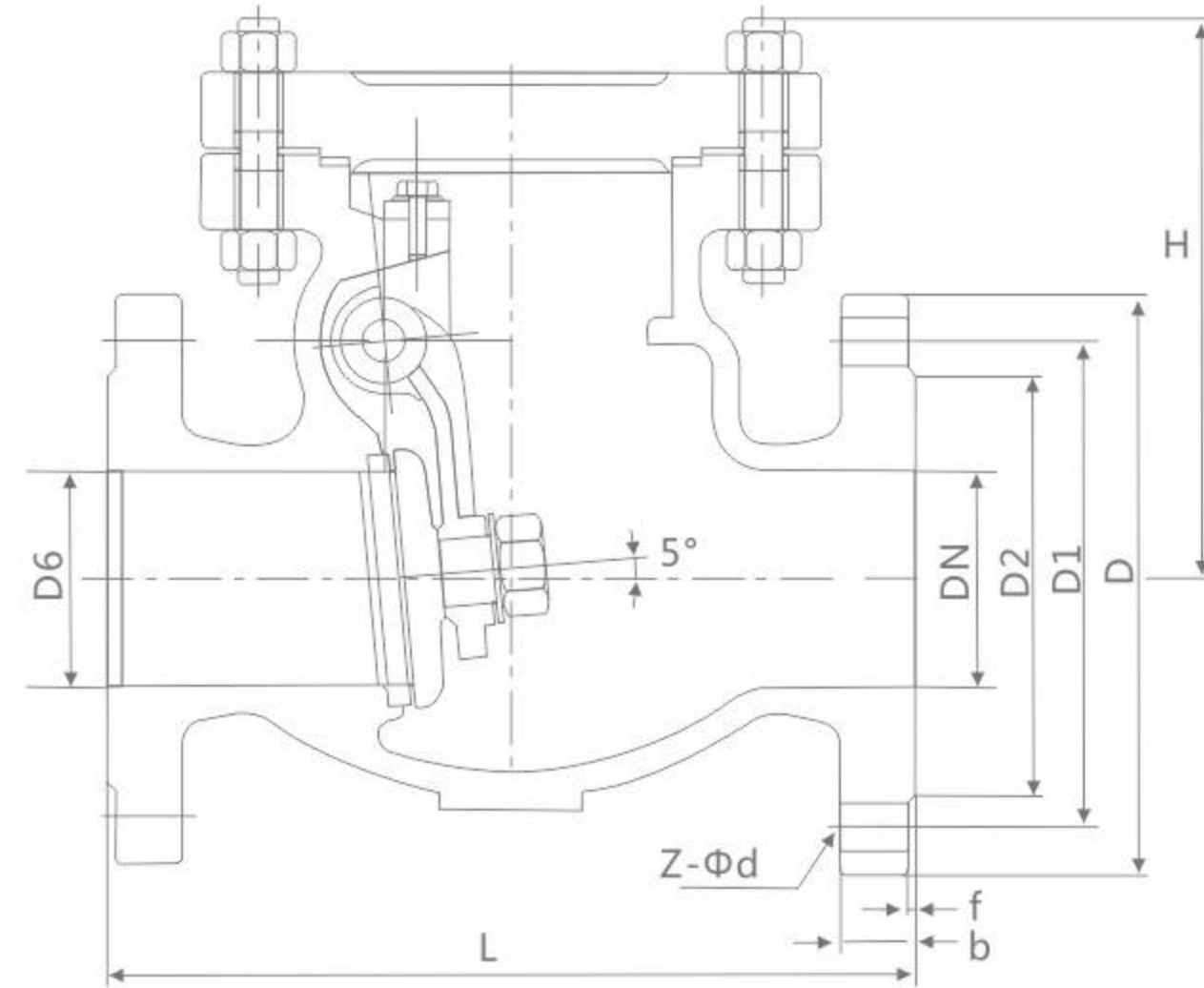

标准

设计与制造按GB/T12236
结构长度按GB/T12221
法兰连接尺寸按JB/T79
检验按JB/T9092

Standards

Design and manufacture as GB/T12236
Face to face dimensions as GB/T12221
End flange dimension as JB/T79
Pressure test as JB/T9092

试验压力 Test Pressure

试验项目 Test Item	壳体试验 Shell Test	密封试验 Seal Test	上密封试验 Back Seal Test	气密封试验 Air Seal Test
介质 Medium	水 Water			气 Air
单位 Unit	MPa	MPa	MPa	MPa
公称压力 Nominal Pressure PN(MPa)	1.6	2.4	1.8	0.5~0.7
	2.5	3.8	2.8	
	4.0	6.0	4.4	
	6.4	9.6	7.0	
	10.0	15.0	11.0	
	16.0	24.0	18.0	

主要零件材料 Materials for Main Parts

名称 Name	材料 Material								
阀体/阀盖 Body/Bonnet	CF8	CF3	CF8M	CF3M	WCB	LCB	WC6	WC9	C5
阀瓣 Wedge	CF8	CF3	CF8M	CF3M	WCB	LCB	WC6	WC9	C5
垫片 Gasket	PTFF				石墨 Graphite				
螺栓 Bolt	不锈钢 Stainless Steel				35CrMoA				
螺母 Nut	不锈钢 Stainless Steel				45、35CrMoA				

国标旋启式止回阀 GB Swing check valve

主要连接尺寸 Main Connection Dimensions

HG/T 20592

型号 Type	公称通径 DN(mm)	尺寸 Dimension(mm)								壁厚 Wall thickness	重量 (kg)
		L	D	D1	D2	D6	b-f	z-Φd	H		
H44W-16 Y	20	150	105	75	55	-	18-2	4-Φ14	100	6.4	5
	25	160	115	85	65	-	18-2	4-Φ14	100	6.4	8
	32	180	140	100	78	-	18-2	4-Φ18	105	6.4	11
	40	200	150	110	85	-	18-3	4-Φ18	115	6.4	13
	50	230	165	125	100	-	18-3	4-Φ18	135	7.9	25
	65	290	185	145	120	-	18-3	8-Φ18	140	11	28
	80	310	200	160	135	-	20-3	8-Φ18	145	11.5	34
	100	350	220	180	155	-	20-3	8-Φ18	165	12.5	42
	125	400	250	210	185	-	22-3	8-Φ18	250	13	60
	150	480	285	240	210	-	22-3	8-Φ22	295	13.5	75
	200	550	340	295	265	-	24-3	12-Φ22	315	15	145
	250	650	405	355	320	-	26-3	12-Φ26	430	16	228
	300	750	460	410	375	-	28-4	12-Φ26	480	18	330
	350	850	520	470	435	-	30-4	16-Φ26	500	20	415
	400	950	580	525	485	-	32-4	16-Φ30	520	21	600
	450	1050	640	585	545	-	40-4	20-Φ30	580	22	802
500	1150	715	650	608	-	44-4	20-Φ33	630	24	1010	
600	1350	840	770	718	-	54-5	20-Φ36	780	26	1558	
H44W-25 Y	20	150	105	75	55	-	18-2	4-Φ14	100	6.4	-
	25	160	115	85	65	-	18-2	4-Φ14	100	6.4	-
	32	180	140	100	78	-	18-2	4-Φ18	105	6.4	-
	40	200	150	110	85	-	18-3	4-Φ18	115	6.4	-
	50	230	165	125	100	-	20-3	4-Φ18	135	7.9	21
	65	290	185	145	120	-	22-3	8-Φ18	140	11	30
	80	310	200	160	135	-	24-3	8-Φ18	145	11.5	37
	100	350	235	190	160	-	24-3	8-Φ22	165	12.5	49
	125	400	270	220	188	-	26-3	8-Φ26	250	13	68
	150	480	300	250	218	-	28-3	8-Φ26	295	13.5	88
	200	550	360	310	278	-	30-3	12-Φ26	315	15	160
	250	650	425	370	332	-	32-3	12-Φ30	430	16	243
	300	750	485	430	390	-	34-4	16-Φ30	480	18	360
	350	850	555	490	448	-	38-4	16-Φ33	500	20	450
	400	950	620	550	505	-	40-4	16-Φ36	520	21	640
	450	1050	670	600	555	-	46-4	20-Φ36	580	22	840
500	1150	730	660	610	-	48-4	20-Φ36	630	24	1070	
600	1350	845	770	718	-	58-5	20-Φ39	780	26	1650	
H44W-40 Y	20	150	105	75	55	51	18-2	4-Φ14	100	6.4	-
	25	160	115	85	65	58	18-2	4-Φ14	100	6.4	-
	32	180	140	100	78	66	18-2	4-Φ18	105	6.4	-
	40	200	150	110	85	76	18-3	4-Φ18	115	6.4	-
	50	230	165	125	100	88	20-3	4-Φ18	135	10	23
	65	290	185	145	120	110	22-3	8-Φ18	140	12	32
	80	310	200	160	135	121	24-3	8-Φ18	145	12.5	41
	100	350	235	190	160	150	24-3	8-Φ22	165	13.5	52
	125	400	270	220	188	176	26-3	8-Φ26	250	14	75
	150	480	300	250	218	204	28-3	8-Φ26	295	16	99
	200	550	375	320	282	260	34-3	12-Φ30	315	17	185
	250	650	450	385	345	313	38-3	12-Φ33	430	18.5	390
	300	750	515	450	408	364	42-4	16-Φ33	480	22	430
	350	850	580	510	465	422	46-4	16-Φ36	500	24	525
	400	950	660	585	535	474	50-4	16-Φ39	520	25	890
	450	1050	685	610	560	524	37-4	20-Φ39	580	26	950
500	1150	755	670	612	576	57-4	20-Φ42	630	30	1300	
600	1350	890	795	730	678	72-5	20-Φ48	780	32	1690	

国标旋启式止回阀 GB Swing check valve

主要外形尺寸及连接尺寸 Main external and connection dimension

HG/T 20592

公称压力 PN(MPa)	公称通径 DN(mm)	尺寸Size(mm)									壁厚 Wall thickness	重量 (kg)
		L	D	D1	D2	D6	b-f	F2	Z-φd	H		
6.3	50	300	180	135	105	88	26-3	4	4-φ22	192	11	36
	65	340	205	160	130	110	26-3	4	8-φ22	207	13	41
	80	380	215	170	140	121	28-3	4	8-φ22	207	14	48
	100	430	250	200	168	150	30-3	4.5	8-φ26	235	15	76
	125	500	295	240	202	176	34-3	4.5	8-φ30	265	15.5	89
	150	550	345	280	240	204	36-3	4.5	8-φ33	297	18	140
	200	650	415	345	300	260	42-3	4.5	12-φ36	357	21	208
	250	775	470	400	352	313	46-3	4.5	12-φ36	405	23	492
	300	900	530	460	412	364	52-4	4.5	16-φ36	465	25	560
	350	1025	600	525	475	422	56-4	5	16-φ39	514	28	870
	400	1150	670	585	525	474	60-4	5	16-φ42	568	30	1085
500	1400	-	705	640	576	-	5	-	620	35	2080	
10.0	50	300	190	145	112	88	30-3	4	4-φ26	192	13	-
	65	340	220	170	138	110	34-3	4	8-φ26	207	13.5	-
	80	380	230	180	148	121	36-3	4	8-φ26	235	15	-
	100	430	265	210	172	150	40-3	4.5	8-φ30	265	18	-
	125	500	315	250	210	176	40-3	4.5	8-φ33	313	19	-
	150	550	355	290	250	204	44-3	4.5	12-φ33	360	23	-
	200	650	430	360	312	260	52-3	4.5	12-φ36	420	28	370
	250	775	505	430	382	313	60-3	4.5	12-φ39	480	32	595
	300	900	585	500	442	364	68-4	4.5	16-φ42	520	36	805
350	1025	655	560	498	422	74-4	5	16-φ48	584	40	1290	
400	1150	715	620	558	474	78-4	5	16-φ48	625	43	1445	
16.0	50	300	195	165	132	88	30-3	4	4-φ26	251	18	-
	65	340	220	190	152	110	34-3	4	8-φ26	282	20	-
	80	380	230	205	168	121	36-3	4	8-φ26	320	24	-
	100	430	265	240	200	150	40-3	4.5	8-φ30	356	30	-
	125	500	315	285	238	176	44-3	4.5	8-φ33	393	35	-
	150	550	355	318	270	204	50-3	4.5	12-φ33	430	35	-
	200	650	430	400	345	260	60-3	4.5	12-φ36	470	40	-
	250	750	515	485	425	313	68-3	4.5	12-φ42	514	45	-
	300	900	585	570	510	364	78-4	4.5	12-φ42	570	50	-
25.0	50	368	210	160	128	70	40-3	5	8-φ25	310	23	-
	65	419	260	203	165	97	48-3	5	8-φ30	346	26	-
	80	470	290	230	190	116	54-3	5	8-φ34	385	30	-
	100	546	360	292	245	138	66-3	6	8-φ41	406	35	-
	125	673	385	318	270	170	76-3	6	12-φ41	534	38	-
	150	705	440	360	305	190	82-3	6	12-φ45	560	40	-
	200	832	535	440	380	245	92-3	6	12-φ51	618	45	-
	250	991	670	572	508	319	110-3	6	16-φ55	673	50	-

国标升降式止回阀 GB Lift check valve

H41W-16C/P/R

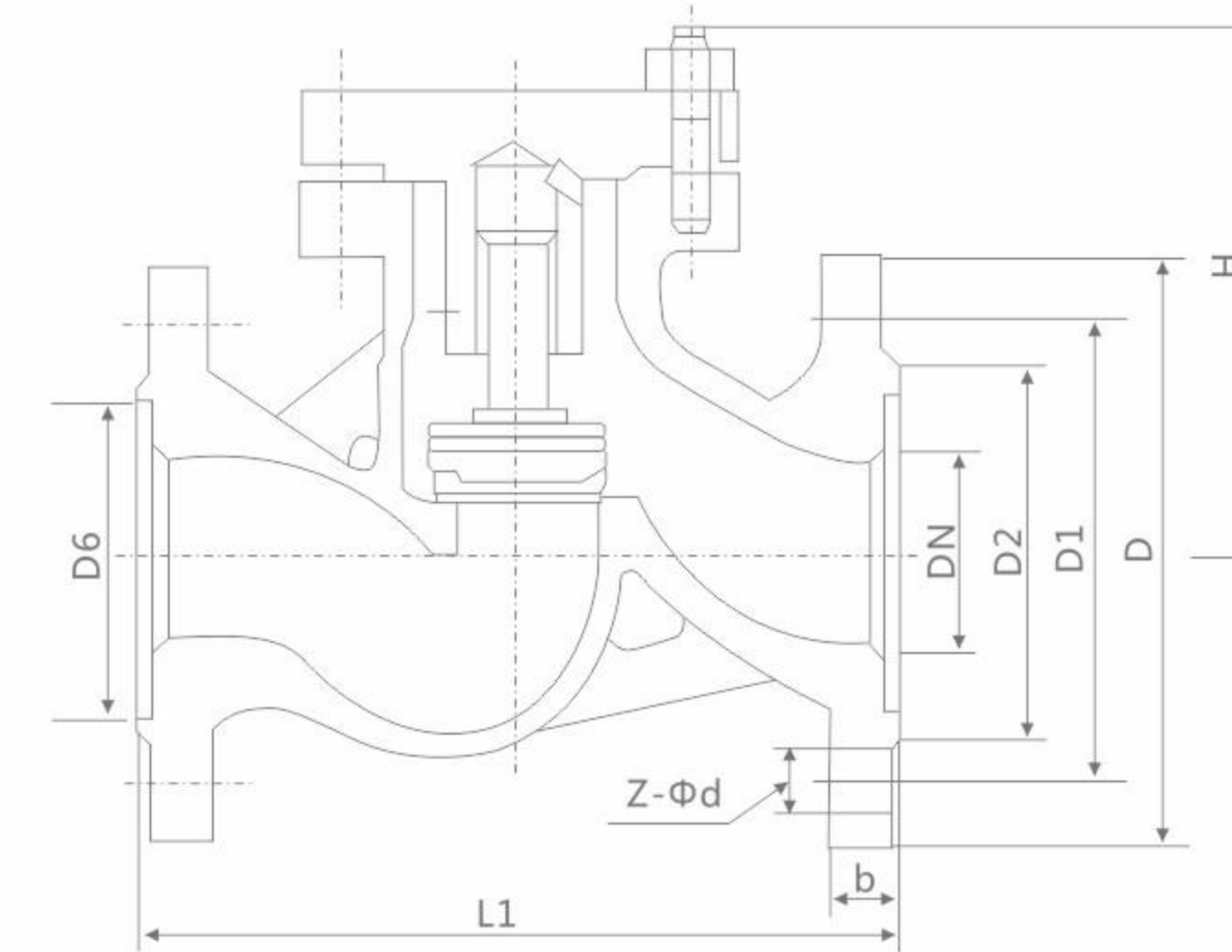

标准

设计与制造按GB/T12235
结构长度按GB/T12221
法兰连接尺寸按JB/T79
检验按JB/T9092

Standards

Design and manufacture as GB/T12235
Face to face dimensions as GB/T12221
End flange dimension as JB/T79
Pressure test as JB/T9092

试验压力 Test Pressure

试验项目 Test Item	壳体试验 Shell Test	密封试验 Seal Test	上密封试验 Back Seal Test	气密封试验 Air Seal Test
介质 Medium	水 Water			气 Air
单位 Unit	MPa	MPa	MPa	MPa
公称压力 Nominal Pressure PN(MPa)	1.6	2.4	1.8	0.5~0.7
	2.5	3.8	2.8	
	4.0	6.0	4.4	
	6.4	9.6	7.0	
	10.0	15.0	11.0	
	16.0	24.0	18.0	

主要零件材料 Materials for Main Parts

名称 Name	材料 Material									
阀体/阀盖 Body/Bonnet	CF8	CF3	CF8M	CF3M	WCB	LCB	WC6	WC9	C5	
阀瓣 Wedge	CF8	CF3	CF8M	CF3M	WCB	LCB	WC6	WC9	C5	
垫片 Gasket	PTFF					石墨 Graphite				
螺栓 Bolt	不锈钢 Stainless Steel					35CrMoA				
螺母 Nut	不锈钢 Stainless Steel					45、35CrMoA				

国标升降式止回阀 GB Lift check valve

主要连接尺寸 Main Connection Dimensions

HG/T 20592

型号 Type	公称通径 DN(mm)	尺寸 Dimension(mm)									壁厚 Wall thickness	重量 (kg)
		L	D	D1	D2	D6	b-f	f1	z-Φd	H		
H H41W-16 Y	15	130	95	65	45	-	16-2	-	4-Φ14	90	6.3	-
	20	150	105	75	55	-	18-2	-	4-Φ14	105	6.3	-
	25	160	115	85	65	-	18-2	-	4-Φ14	115	6.3	-
	32	180	140	100	78	-	18-2	-	4-Φ18	120	6.3	-
	40	200	150	110	85	-	18-3	-	4-Φ18	130	6.3	-
	50	230	165	125	100	-	18-3	-	4-Φ18	140	7.9	21
	65	290	185	145	120	-	18-3	-	8-Φ18	150	11	28
	80	310	200	160	135	-	20-3	-	8-Φ18	170	11.5	35
	100	350	220	180	155	-	20-3	-	8-Φ18	185	12.5	45
	125	400	250	210	185	-	22-3	-	8-Φ18	195	13	65
	150	480	285	240	210	-	22-3	-	8-Φ22	225	13.5	80
	200	600	340	295	265	-	24-3	-	12-Φ22	250	15	146
	250	650	405	355	320	-	26-3	-	12-Φ26	270	16	228
	300	750	460	410	375	-	28-3	-	12-Φ26	300	18	330
H H41W-25 Y	15	130	95	65	45	-	16-2	-	4-Φ14	90	6.3	-
	20	150	105	75	55	-	18-2	-	4-Φ14	105	6.3	-
	25	160	115	85	65	-	18-2	-	4-Φ14	115	6.3	-
	32	180	140	100	78	-	18-2	-	4-Φ18	120	6.3	-
	40	200	150	110	85	-	18-3	-	4-Φ18	130	6.3	-
	50	230	165	125	100	-	20-3	-	4-Φ18	140	7.9	21
	65	290	185	145	120	-	22-3	-	8-Φ18	150	11	30
	80	310	200	160	135	-	24-3	-	8-Φ18	170	11.5	37
	100	350	235	190	160	-	24-3	-	8-Φ22	185	12.5	49
	125	400	270	220	188	-	26-3	-	8-Φ26	195	13	68
	150	480	300	250	218	-	28-3	-	8-Φ26	225	13.5	88
	200	600	360	310	278	-	30-3	-	12-Φ26	250	15	161
	250	650	425	370	335	-	32-3	-	12-Φ30	270	16	243
	300	750	485	430	390	-	34-4	-	16-Φ30	300	18	360
H H41W-40 Y	25	160	115	85	65	58	18-2	4	4-Φ14	115	6.3	-
	32	180	140	100	78	66	18-2	4	4-Φ18	120	6.3	-
	40	200	150	110	85	76	18-3	4	4-Φ18	130	6.3	-
	50	230	165	125	100	88	20-3	4	4-Φ18	140	10	23
	65	290	185	145	120	110	22-3	4	8-Φ18	150	12	32
	80	310	200	160	135	121	24-3	4	8-Φ18	170	12.5	41
	100	350	235	190	160	150	24-3	4.5	8-Φ22	185	13.5	52
	125	400	270	220	188	176	26-3	4.5	8-Φ26	195	14	75
	150	480	300	250	218	204	28-3	4.5	8-Φ26	225	16	99
	200	600	375	320	282	260	34-3	4.5	12-Φ30	250	17	185
H H41W-64 Y	15	170	105	75	55	40	20-2	4	4-Φ14	110	7.4	-
	20	190	130	90	68	51	22-2	4	4-Φ18	125	7.9	-
	25	210	140	100	78	58	24-2	4	4-Φ18	152	7.9	-
	32	230	155	110	82	66	26-2	4	4-Φ22	168	8.6	-
	40	260	170	125	95	76	28-3	4	4-Φ22	170	9.4	-
	50	300	180	135	105	88	26-3	4	4-Φ22	188	11	36
	65	340	205	160	130	110	26-3	4	8-Φ22	205	13	41
	80	380	215	170	140	121	28-3	4	8-Φ22	230	14	48
	100	430	250	200	168	150	30-3	4.5	8-Φ26	280	15	76
	125	500	295	240	202	176	34-3	4.5	8-Φ30	300	15.5	89
	150	550	345	280	240	204	36-3	4.5	8-Φ33	350	18	140
	200	650	415	345	300	260	42-3	4.5	12-Φ36	400	21	208

国标立式止回阀 GB Vertical check valve

H42H-16C、P、R
16
40

用途 Purpose

本阀门用于工业管道上作阻止介质逆流的装置。

性能规范 The performance specification

试验压力：公称压力 (MPa) 1.6 / 2.5 / 4.0 ;

壳体试验：2.4 / 3.8 / 6.0 ;

密封试验：1.8 / 2.8 / 4.4 ;

阀体材料：WCB(C) / CF8(P) / CF8M (R) / WC6 / WC9 ;

工作温度：≤425 / ≤100 / ≤100 / ≤550 / ≤550 ;

适用介质：水、蒸汽、油品、硝酸类、醋酸类、

执行标准：设计制造：GB12235 结构长度：GB12221

连接法兰：JB/T9-1994

试验与检验：JB/T9092-1999

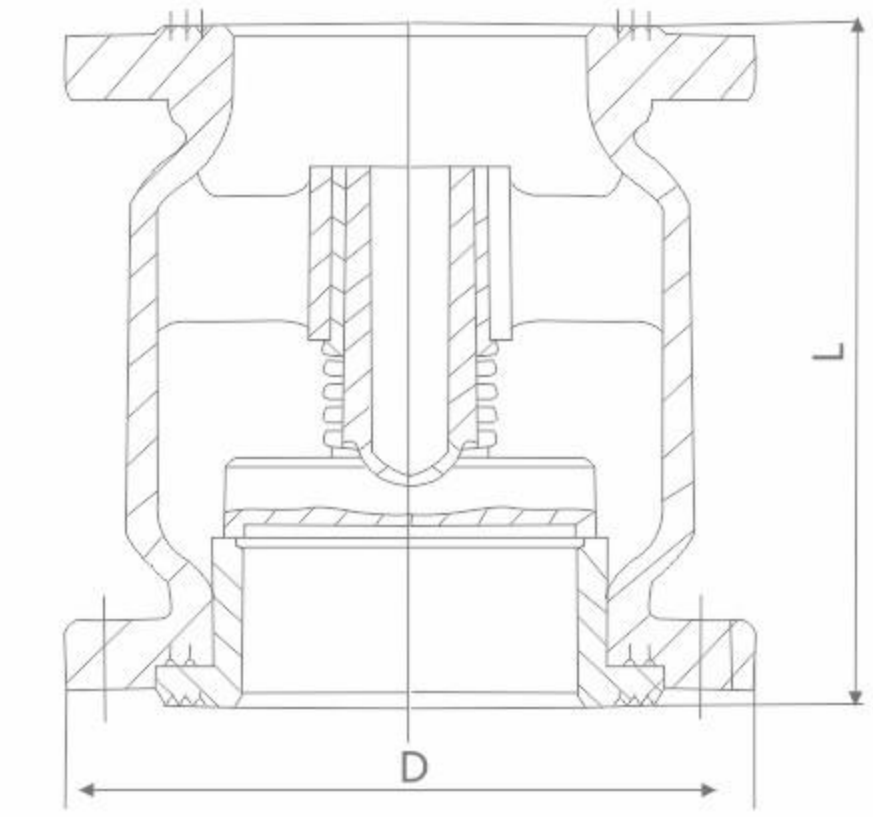

主要外形尺寸及连接尺寸 Main external and connection dimension

H42H-16C、P、R

公称通径 DN(mm)	尺寸 Dimension(mm)					
	L	D	D1	D2	b-f	z-Φd
15	80	95	65	45	14-2	4-Φ14
20	95	105	75	55	14-2	4-Φ14
25	105	115	85	65	14-2	4-Φ14
32	150	135	100	78	16-2	4-Φ18
40	160	145	110	85	16-3	4-Φ18
50	170	160	125	100	16-3	4-Φ18
65	180	180	145	120	18-3	4-Φ18
80	200	195	160	135	20-3	8-Φ18
100	210	215	180	155	20-3	8-Φ18
125	275	245	210	185	22-3	8-Φ18
150	300	280	240	210	24-3	8-Φ23
200	380	335	295	265	26-3	12-Φ23
250	450	405	355	320	30-3	12-Φ25

主要外形尺寸及连接尺寸 Main external and connection dimension

H42H-25C、P、R

公称通径 DN(mm)	尺寸 Dimension(mm)					
	L	D	D1	D2	b-f	z-Φd
15	80	95	65	45	16-2	4-Φ14
20	95	105	75	55	16-2	4-Φ14
25	105	115	85	65	16-2	4-Φ14
32	150	135	100	78	18-2	4-Φ18
40	160	145	110	85	18-2	4-Φ18
50	170	160	125	100	20-3	4-Φ18
65	180	180	145	120	22-3	8-Φ18
80	200	195	160	135	22-3	8-Φ18
100	210	230	190	160	24-3	8-Φ23
125	275	270	220	188	28-3	8-Φ25
150	300	300	250	218	30-3	8-Φ25
200	380	360	310	278	34-3	12-Φ25
250	450	425	370	335	36-3	12-Φ30

阀门订货号 Valve order number

当您询问或订购我们的阀门时不必详细了解我们的阀门订货编号系统。只要您能提供了您所选阀门的充分描述，我们的销售部门就可以将其编译成相应的阀门订货号。所选阀门的充分描述应该是从阀门类型开始的，接着就是阀门口径、压力等级、两端连接形式、密封面材或根据API 602所规定的内件号等。

下面是我们给出的一个例子，目的是想用图示的方法来说明一个典型的阀门订货号，但如果需要详细地说明，请向我们咨询。

When you ask or order our valves do not have to learn more about our valves order numbering system. As long as you can provide your full description of the selected valve, our sales department can be made up Translated into the corresponding valve order number. The selected valve fully described should be started from the valve type, then there is the valve diameter, pressure level, form of connection on both ends, sealing surface material or according to API 602 Regulation of internal parts and so on. Below is we give an example, the purpose is to want to use the method of graphic to illustrate a typical valve order number, but if you need to elaborate, please consult us.

F		P		3		Y		2"	15	L		Y		V		
通径形式 Port type		阀体与阀盖连接形式 Body and bonnet connection		末端连接形式 End connection		设计结构特点 Design feaature		口径 Size		阀门类型 Type of valve		密封(阀瓣/阀座) Seal disc/seat		阀门材质 Body materials		
缩径 Reduced	默认 Default	体、盖 螺栓链接 Bolt and bonnet screwed	默认 Default	凸面法兰 Convex flange	1	"Y"型阀门 "Y" type valves	Y	3/8"	Class150	1	闸阀 Gate valves	G	13Cr/13Cr	H	A105	C
全通径 Full bore	F			环连接 Ring connection surface	2	低温阀门 Cryogenic valves	D	3/4"	Class300	3	升降式上回阀 Lift check valves	C	STL/STL	Y	A350LF2	E
		体、盖 焊接链接 Bolt and bonnet welded	W	对接焊 Butt welded	3	波纹管阀门 Bellows valves	W	1/2"	Class600	6	球形止回阀 Ball check valves	B	13Cr/STL	HY	A350LF3	F
				承插焊 Socket welding	4	阀体延长端阀门 Body extended valves	E	1"	Class800	8	截止阀 Globe valves	L	304/304	S	A182F11	A
		压力自紧式 Pressure seal	P	螺纹连接 Screw	5			1/4"	Class900	9	旋启式止回阀 Swing check valves	S	304/PTFE	SF	A182F22	V
				保温阀 Jacket valves				1/2"	Class1500	15	球阀 Ball valves	Q	Monel/Monel	M	A182F304	P
								2"	Class2500	25	线性调节阀 Linear regulating valves	T	尼龙Inconel	I	A182F316	R
											过滤器 strainer	R	Nylon	N	A182F304L	S
												PTFE	F	A182F316L	L	
												Hastelloy	HC	A182F91	Z	
														A182F51	B	
														Monel	M	
														Hastelloy	H	
														20合金Alloy	N	

典型零件材料表 Main part materials list

零件名称 Part name	A105/F6a	A105/F6aHFS	LF2/304	F11/F6aHT	F304(L)304(L)	F316(L)316(L)	F51/F51
阀体Body	A105	A105+HF	Lf2	F11+HF	F304	F316	F51
阀瓣Disc	F6a	F6a	F304	F6aHF	F304(L)	F216(L)	F51
阀杆Stem	410	410	304	410	304(L)	316(L)	F51
垫片Gasket	304+柔性石墨 Flexible graphite	304+柔性石墨 Flexible graphite	304+柔性石墨 Flexible graphite	304+柔性石墨 Flexible graphite	304+柔性石墨 Flexible graphite	304+柔性石墨 Flexible graphite	304+柔性石墨 Flexible graphite
阀盖Bonnet	A105	A105	LF2	F11	F304(L)	F316(L)	F51
螺栓Bolt	B7	B7	L7	B16	B8(M)	B8(M)	B8M
销轴Pin	410	410	410	410	304	304	304
填料压套Gland	410	410	304	410	304	316	F51
活节螺栓Gland Eyebolt	B7	B7	L7	B16	B8(M)	B8(M)	B8M
填料压盖Gland Flange	A105	A105	LF2	F304	F304(L)	F316(L)	F304
六角螺母Hex Nut	2H	2H	7	7	8(M)	8(M)	8M
阀杆螺母Stem Nut	410	410	410	410	410	410	410
缩紧螺母Locking Nut	35	35	35	35	35	35	35
铭牌Nameplate	AL	AL	AL	AL	AL	AL	AL
手轮 Handwheel	A197	A197	A197	A197	A197	A197	A197
填料 Packing	石墨 Graphite	石墨 Graphite	石墨 Graphite	石墨 Graphite	石墨 Graphite	石墨 Graphite	石墨 Graphite

05

RUITONG
VALVE

锻钢阀系列

FORGED STEEL VALVE SERIES



内螺纹与承插焊闸阀

Internal thread and socket welding gate valve

锻钢法兰闸阀

Forged steel flange gate valve

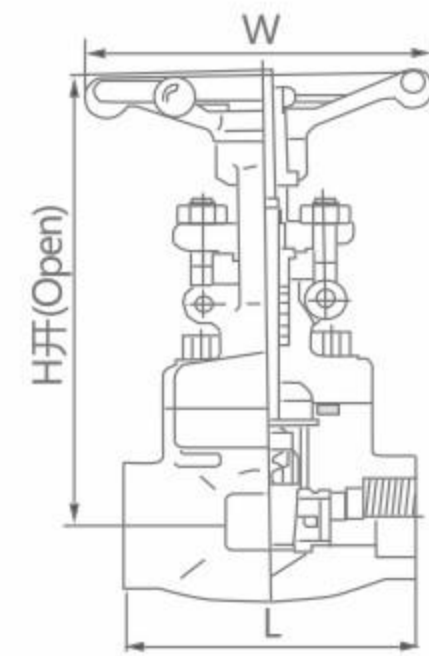

CL800

规格(NPS) Specification	R.P	-	1/2	3/4	1	1 1/4	1 1/2	2	2 1/2	3
	F.P	1/4	3/8	1/2	3/4	1	1 1/4	1 1/2	2	2 1/2
结构长度(mm)Face to face	L	79	79	92	111	120	120	140	178	180
手轮直径(mm) Handwheel diameter	W	100	100	100	125	160	160	180	200	220
中心高度(开)(mm)Height	H	161	161	163	196	223	251	290	333	370
流道孔径(mm)Flow port dimension	d	8	10.5	13.5	18	24	29	36.5	45	51
重量(Kg)Weight		2.22	2.3	4.24	4.24	5.7	7.05	10.9	16.3	24

焊接连接阀盖, 缩径和全径, 明杆支架 (OS&Y), 末端连接为螺纹或承插焊或对焊, 设计按APL602
Bolted bonnet, full port reducing port outside screw and yoke(OS&Y)
Threaded, butt-welded or socket welded ends; design to APL602

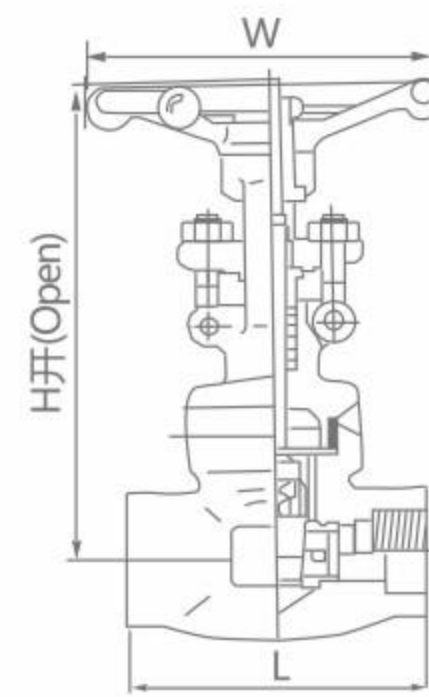

CL800

规格(NPS) Specification	R.P	-	1/2	3/4	1	1 1/4	1 1/2	2	2 1/2	3
	F.P	1/4	3/8	1/2	3/4	1	1 1/4	1 1/2	2	2 1/2
结构长度(mm)Face to face	L	79	79	92	111	120	120	140	178	180
手轮直径(mm) Handwheel diameter	W	100	100	100	125	160	160	180	200	220
中心高度(开)(mm)Height	H	161	161	163	196	223	251	290	333	370
流道孔径(mm)Flow port dimension	d	8	10.5	13.5	18	24	29	36.5	45	51
重量(Kg)Weight		1.9	1.9	2.1	3.2	5.2	6.9	10.4	15.8	22

焊接连接阀盖, 缩径和全径, 明杆支架 (OS&Y), 末端连接为螺纹或承插焊或对焊, 设计按APL602
Bolted bonnet, full port reducing port outside screw and yoke(OS&Y)
Threaded, butt-welded or socket welded ends; design to APL602

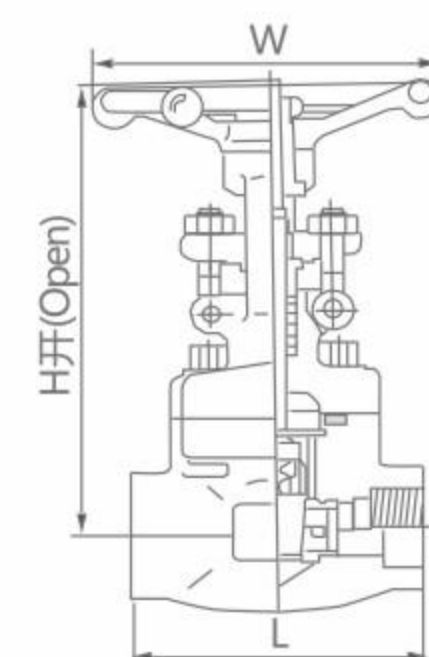

CL900-CL1500

规格(NPS) Specification	R.P	-	1/2	3/4	1	1 1/4	1 1/2	2	2 1/2	3
	F.P	1/4	3/8	1/2	3/4	1	1 1/4	1 1/2	2	2 1/2
结构长度(mm)Face to face	L	92	111	111	120	120	140	178	180	-
手轮直径(mm) Handwheel diameter	W	100	125	125	160	160	180	200	220	-
中心高度(开)(mm)Height	H	191	191	192	219	243	296	316	370	-
流道孔径(mm)Flow port dimension	d	8	10.5	13.5	18	24	29	36.5	45	-
重量(Kg)Weight		2.4	4.3	4.4	6	7.2	11.4	16	23	-

焊接连接阀盖, 缩径和全径, 明杆支架 (OS&Y), 末端连接为螺纹或承插焊或对焊, 设计按APL602
Bolted bonnet, full port reducing port outside screw and yoke(OS&Y)
Threaded, butt-welded or socket welded ends; design to APL602

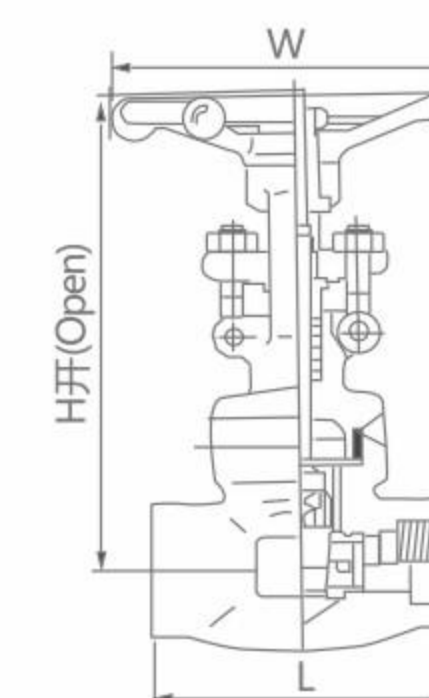

CL900-CL1500

规格(NPS) Specification	R.P	-	1/2	3/4	1	1 1/4	1 1/2	2	2 1/2	3
	F.P	1/4	3/8	1/2	3/4	1	1 1/4	1 1/2	2	2 1/2
结构长度(mm)Face to face	L	92	111	111	120	120	140	178	180	-
手轮直径(mm) Handwheel diameter	W	100	125	125	160	160	180	200	220	-
中心高度(开)(mm)Height	H	191	191	192	219	243	296	316	370	-
流道孔径(mm)Flow port dimension	d	8	10.5	13.5	18	24	29	36.5	45	-
重量(Kg)Weight		2.3	4	4	4.8	7.1	11	16	22.8	-

螺栓连接阀盖, 缩径和全径, 明杆支架 (OS&Y)
Threaded, butt-welded or socket welded ends; design to APL602
焊接连接阀盖, 缩径和全径, 明杆支架 (OS&Y), 末端连接为螺纹或承插焊或对焊, 设计按APL602

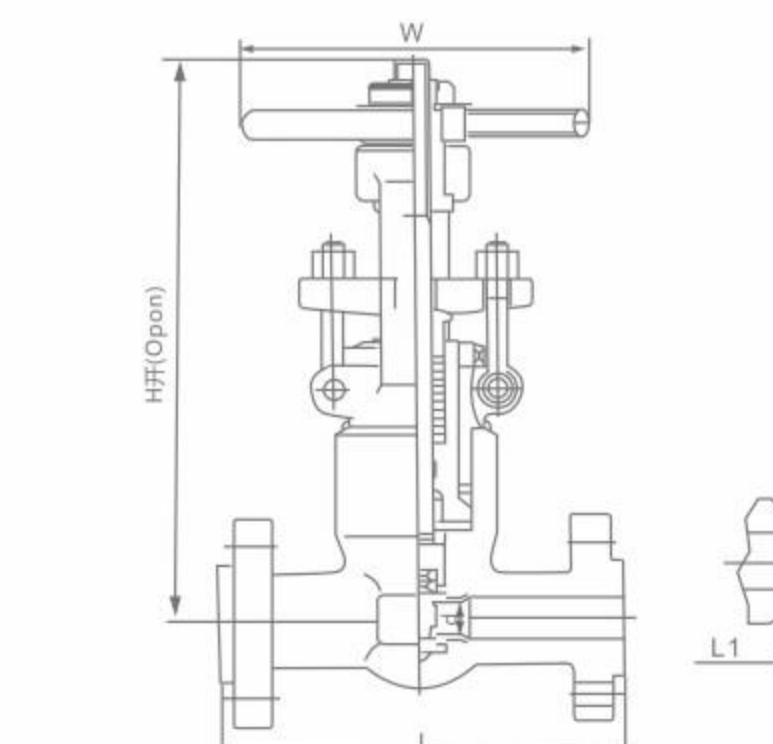
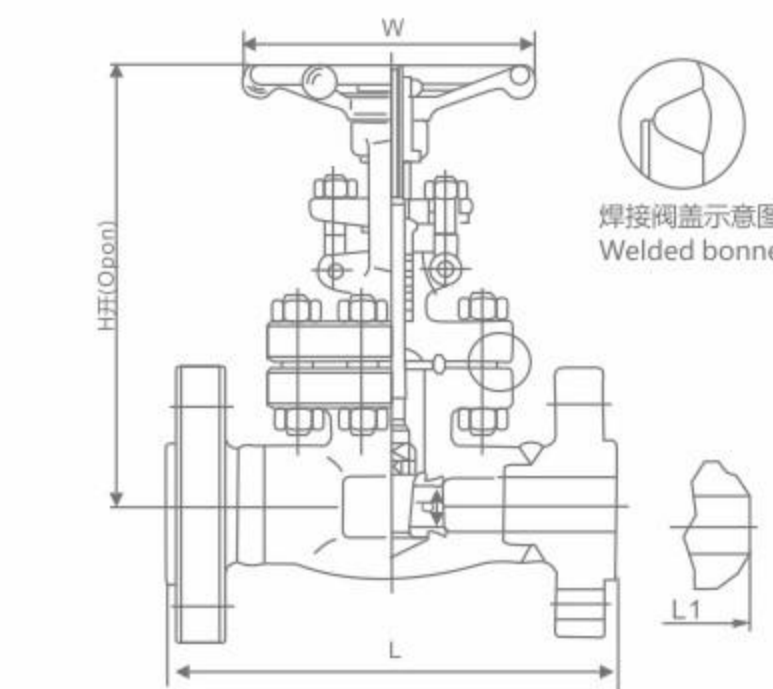
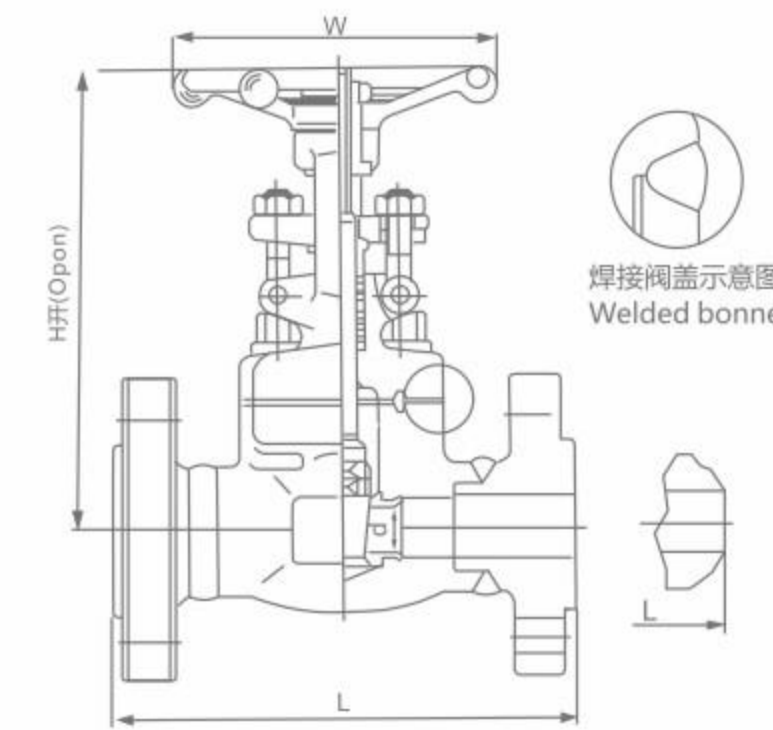
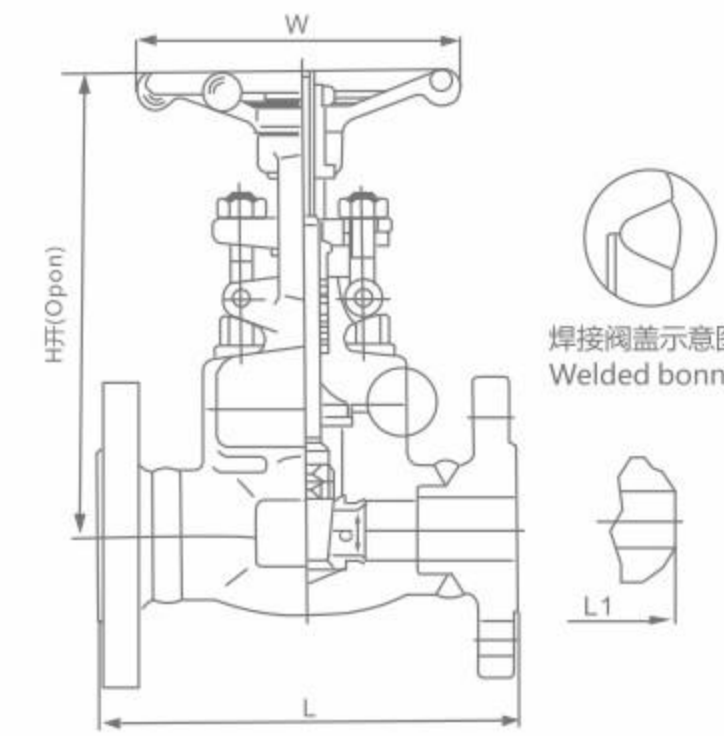

CL150-300-600

规格(NPS) Specification		F.P	1/4	3/8	1/2	3/4	1	1 1/4	1 1/2	2	2 1/2
结构长度(mm) Face to face	CL150	L(RF) L1(BW)	-	-	108	117	127	140	165	178	190
	CL300		-	-	140	152	165	178	190	216	241
	CL600		-	-	165	190	216	229	241	292	330
手轮直径(mm) Handwheel diameter	W	-	-	100	100	125	160	160	180	200	
中心高度(开) (mm)Height	CL150/CL300	H	-	-	176	184	217	226	250	290	357
	CL600		-	-	161	163	196	226	250	290	357
流道孔径(mm) Flow port dimension	d	-	-	10	13.5	18	24	29	36.5	45	
重量(Kg) Weight	CL150	RF	-	-	3.4	3.98	6.12	7.2	10.4	15.5	24.5
		BW	-	-	2.8	3.3	5.4	6.5	8.2	12.5	20
	CL300	RF	-	-	3.77	4.89	7.23	9.6	12.64	18	26.2
		BW	-	-	3.5	4.4	6.8	8.1	9.2	15.4	22
	CL600	RF	-	-	4.2	5.8	8.8	12.1	15.6	19.5	32
		BW	-	-	4.5	5.1	8.2	10.5	12.4	20.1	28

螺栓连接阀盖, 缩径和全径, 明杆支架 (OS&Y), 末端连接为法兰或对焊连接, 设计按API 602;BS5352
Bolted bonnet, full port reducing port outside screw and yoke(OS&Y)
Flange-welded or but-welded ends; design to API602;BS5352

CL900-CL1500

规格(NPS) Specification		F.P	1/4	3/8	1/2	3/4	1	1 1/4	1 1/2	2
结构长度(mm) Face to face	L(RF)L1(BW)	-	-	-	216	229	254	279	305	368
	L(RTJ)	-	-	-	216	229	254	279	305	371
手轮直径(mm) Handwheel diameter	W	-	-	-	125	125	160	180	200	220
中心高度(开)(mm) Height	H	-	-	-	191	192	219	257	296	316
流道孔径(mm) Flow port dimension	d	-	-	-	13.5	18	24	29	36.5	45
重量(Kg) Weight		-	-	-	7.2	11.5	15.6	16.2	22.6	28.2

螺栓连接阀盖, 缩径和全径, 明杆支架 (OS&Y), 末端连接为法兰或对焊连接, 设计按API 602;BS5352
Bolted bonnet, full port reducing port outside screw and yoke(OS&Y)
Flange-welded or but-welded ends; design to API602;BS5352

CL2500

规格(NPS) Specification		F.P	1/4	3/8	1/2	3/4	1	1 1/4	1 1/2	2
结构长度(mm) Face to face	L(RF)L1(BW)	-	-	-	264	273	305	-	384	451
	L(RTJ)	-	-	-	264	273	308	-	387	454
手轮直径(mm) Handwheel diameter	W	-	-	-	125	160	160	-	200	240
中心高度(开)(mm) Height	H	-	-	-	207	240	258	-	355	370
流道孔径(mm) Flow port dimension	d	-	-	-	13.5	13.5	19	-	20	36.5
重量(Kg) Weight		-	-	-	19.5	21.5	42	-	65	95

螺栓连接阀盖, 缩径和全径, 明杆支架 (OS&Y), 末端连接为法兰或对焊连接, 设计按API 602;BS5352
Bolted bonnet, full port reducing port outside screw and yoke(OS&Y)
Flange-welded or but-welded ends; design to API602;BS5352

CL2500

规格(NPS) Specification		F.P	1/4	3/8	1/2	3/4	1	1 1/4	1 1/2	2
结构长度(mm) Face to face	L(RF)L1(BW)	-	-	-	264	273	308	-	384	451
	L(RTJ)	-	-	-	264	273	308	-	387	454
手轮直径(mm) Handwheel diameter	W	-	-	-	200	200	200	-	280	300
中心高度(开)(mm) Height	H	-	-	-	325	325	327	-	478	540
流道孔径(mm) Flow port dimension	d	-	-	-	13.5	13.5	19	-	30	36.5
重量(Kg) Weight		-	-	-	14.6	16.8	17.6	-	25	31.9

螺栓连接阀盖, 缩径和全径, 明杆支架 (OS&Y), 末端连接为法兰或对焊连接, 设计按API 602;BS5352
Bolted bonnet, full port reducing port outside screw and yoke(OS&Y)
Flange-welded or but-welded ends; design to API602;BS5352

内螺纹与承插焊截止阀

Female thread and socket weld globe valve

法兰与对焊截止阀

Flange and butt weld globe valve

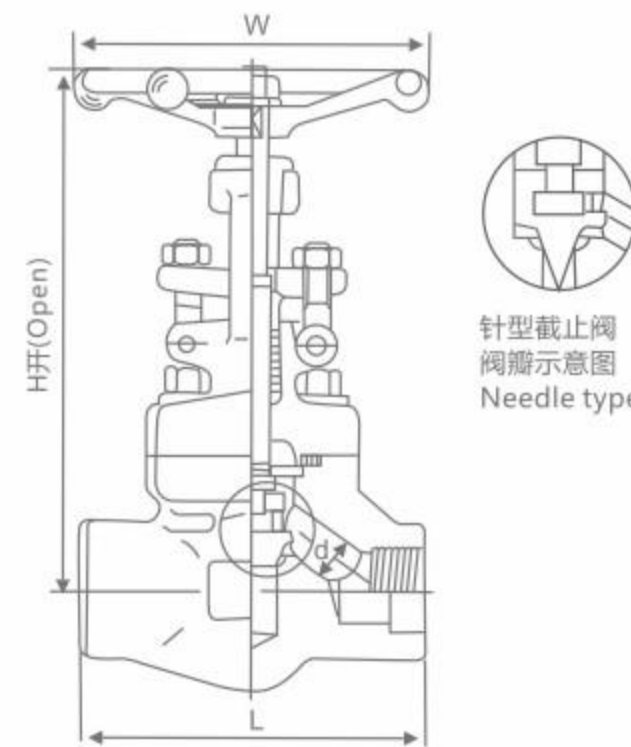

针型截止阀
阀瓣示意图
Needle type

CL800

规格(NPS)Specification	R. P	1/2	3/4	1	1 1/4	1 1/2	2	2 1/2	3	
	F. P	1/4	3/8	1/2	3/4	1	1 1/4	1 1/2	2	2 1/2
结构长度(mm)Face to face	L	79	79	92	111	120	152	172	200	-
手轮直径(mm)Handwheel diameter	W	100	100	100	125	160	160	180	200	-
中心高度(开)(mm)Height	H	164	164	164	203	224	260	300	355	-
流道孔径(mm)Flow port dimension	d	7	9	13	17.5	23	30	35	46	-
重量(Kg)Weight		1.9	2.28	2.37	4.3	5.75	7.8	12.5	17.5	-

螺栓连接阀盖, 缩径和全径, 明杆支架 (OS&Y), 末端连接可按螺纹或承插焊, 设计按BS5352
Bolted bonnet, full port reducing port outside screw and yoke(OS&Y)
Threaded, butt-welded or socket welded ends; design to BS5352

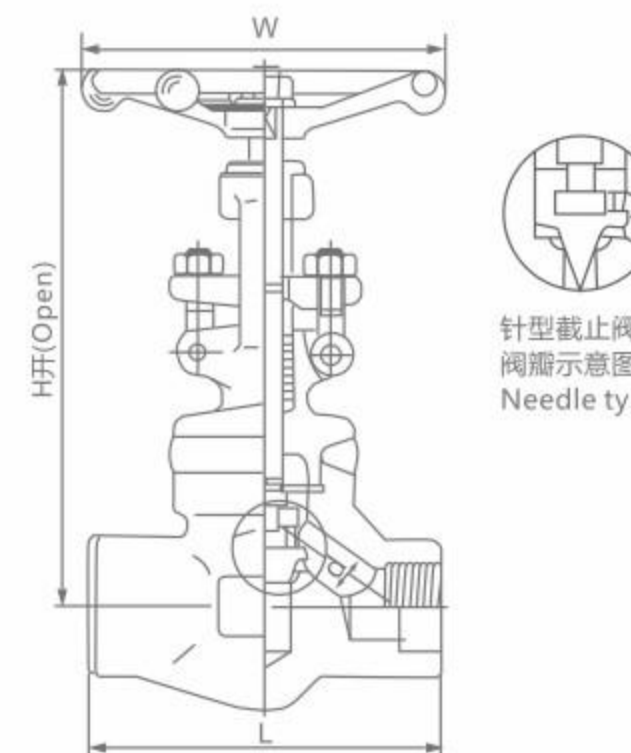

针型截止阀
阀瓣示意图
Needle type

CL800

规格(NPS)Specification	R. P	1/2	3/4	1	1 1/4	1 1/2	2	2 1/2	3	
	F. P	1/4	3/8	1/2	3/4	1	1 1/4	1 1/2	2	2 1/2
结构长度(mm)Face to face	L	79	79	92	111	120	152	172	200	-
手轮直径(mm)Handwheel diameter	W	100	100	100	125	160	160	180	200	-
中心高度(开)(mm)Height	H	164	164	164	203	224	260	300	355	-
流道孔径(mm)Flow port dimension	d	7	9	13	17.5	23	30	35	46	-
重量(Kg)Weight		1.7	1.7	1.9	3.3	5.2	6.8	10.6	13.8	-

螺栓连接阀盖, 缩径和全径, 明杆支架 (OS&Y), 末端连接可按螺纹或承插焊, 设计按BS5352
Bolted bonnet, full port reducing port outside screw and yoke(OS&Y)
Threaded, butt-welded or socket welded ends; design to BS5352

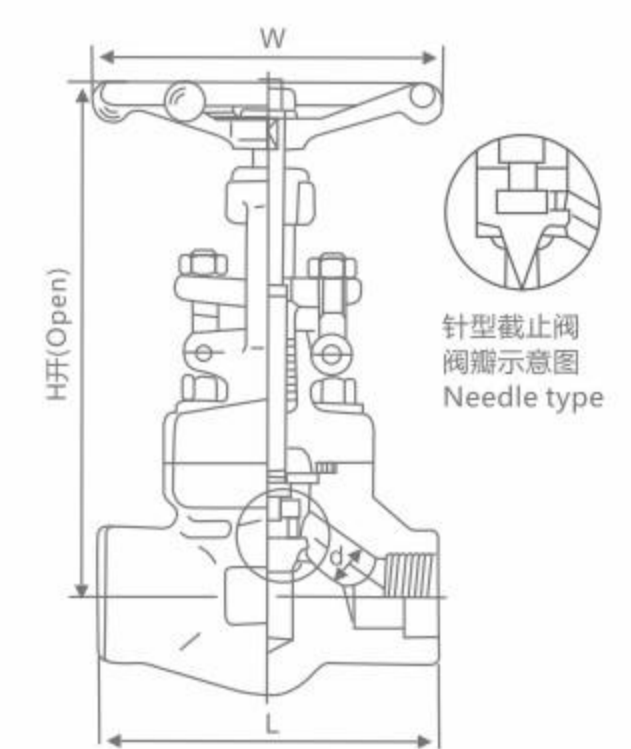

针型截止阀
阀瓣示意图
Needle type

CL900-CL1500

规格(NPS)Specification	R. P	1/2	3/4	1	1 1/4	1 1/2	2	2 1/2	3
	F. P	1/4	3/8	1/2	3/4	1	1 1/4	1 1/2	2
结构长度(mm)Face to face	L	92	111	111	120	152	172	200	220
手轮直径(mm)Handwheel diameter	W	100	125	125	160	160	180	200	240
中心高度(开)(mm)Height	H	171	207	207	240	258	330	355	370
流道孔径(mm)Flow port dimension	d	7	12	15	20	28	32	40	45
重量(Kg)Weight		2.3	3.6	3.7	6.8	7.6	11.6	15	21.9

螺栓连接阀盖, 缩径和全径, 明杆支架 (OS&Y), 末端连接可按螺纹或承插焊, 设计按BS5352
Bolted bonnet, full port reducing port outside screw and yoke(OS&Y)
Threaded, butt-welded or socket welded ends; design to BS5352

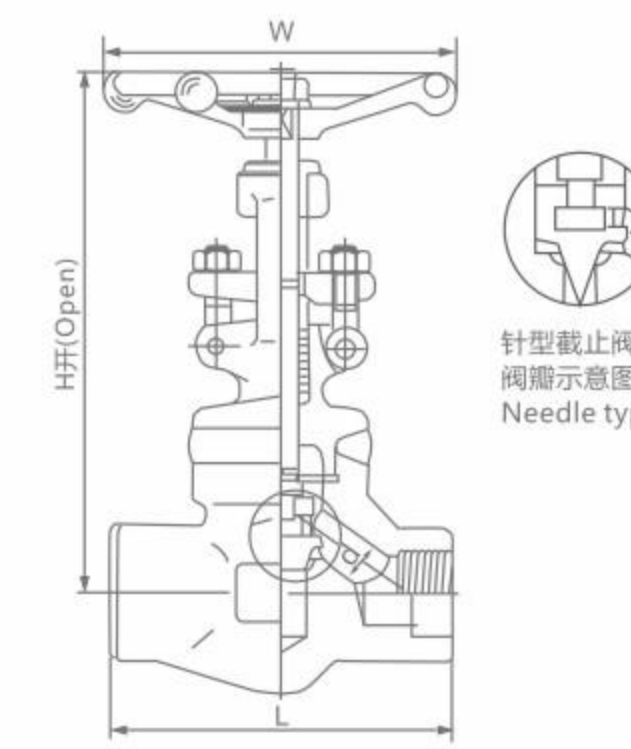

针型截止阀
阀瓣示意图
Needle type

CL900-CL1500

规格(NPS)Specification	R. P	1/2	3/4	1	1 1/4	1 1/2	2	2 1/2	3
	F. P	1/4	3/8	1/2	3/4	1	1 1/4	1 1/2	2
结构长度(mm)Face to face	L	92	111	111	120	152	172	200	220
手轮直径(mm)Handwheel diameter	W	100	125	125	160	160	180	200	240
中心高度(开)(mm)Height	H	171	207	207	240	258	330	355	370
流道孔径(mm)Flow port dimension	d		12	15	20	28	32	40	45
重量(Kg)Weight		2.2	3.3	3.4	5.6	6.0	10.3	14.2	18.0

螺栓连接阀盖, 缩径和全径, 明杆支架 (OS&Y), 末端连接可按螺纹或承插焊, 设计按BS5352
Bolted bonnet, full port reducing port outside screw and yoke(OS&Y)
Threaded, butt-welded or socket welded ends; design to BS5352

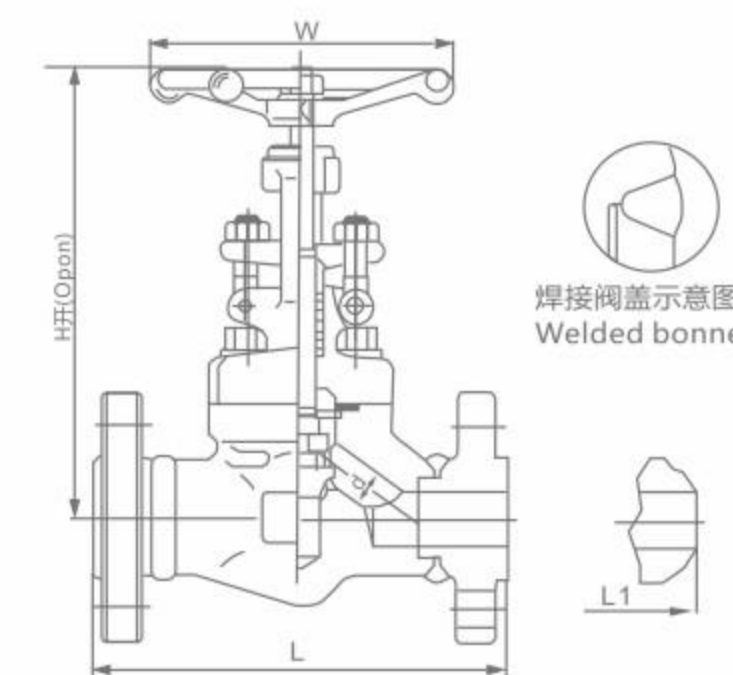

焊接阀盖示意图
Welded bonnet

CL150-300-600

规格(NPS) Specification	F. P	1/4	3/8	1/2	3/4	1	1 1/4	1 1/2	2	
结构长度(mm) Face to face	CL150	-	-	108	117	127	140	165	203	
	CL300	-	-	152	178	203	216	229	267	
	CL600	-	-	165	190	216	229	241	292	
手轮直径(mm) Handwheel diameter	W	-	-	100	100	125	160	160	180	
中心高度(开) (mm)Height	CL150/CL300	-	-	180	184	217	224	260	300	
	CL600	-	-	164	164	203	224	260	300	
流道孔径(mm)Flow port dimension	d	-	-	9	13	17.5	23	30	35	
重量(Kg) Weight	CL150	RF	-	-	3.45	4.0	6.19	9.6	10.5	17
		BW	-	-	2.3	3.6	7.8	8.2	12.0	15.0
	CL300	RF	-	-	3.8	5.1	7.2	12	13.5	19.7
		BW	-	-	2.8	4.0	8.5	9.2	12.6	16.8
	CL600	RF	-	-	5.6	7.8	12.5	17	23.5	38.8
		BW	-	-	3.4	4.7	9.2	10.5	13.3	18.9

注: 如需法兰和阀体一体式锻造的请与TIANBANG销售人员联系。

Flange integrity Forged Steel Valve Enquiry Please Contact Sales Department.

螺栓连接阀盖, 全径, 明杆支架 (OS&Y), 末端连接为焊接法兰或对焊连接, 设计按Bs5352

Welded bonnet, full port outside screw and yoke(OS&Y), Flange-welded or but-welded ends; design to BS5352

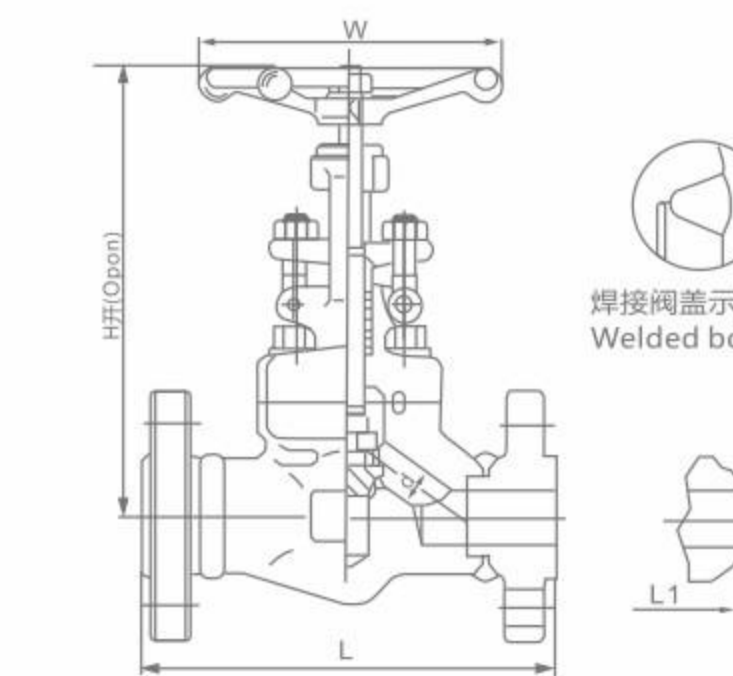

焊接阀盖示意图
Welded bonnet

CL900-CL1500

规格(NPS) Specification	F. P	1/4	3/8	1/2	3/4	1	1 1/4	1 1/2	2
结构长度(mm) Face to face	L(RF)L1(BW)	-	-	216	229	254	279	305	368
	L(RTJ)	-	-	216	229	254	279	305	371
手轮直径(mm) Handwheel diameter	W	-	-	125	125	160	160	180	200
中心高度(开)(mm)Height	H	-	-	207	207	230	160	300	355
流道孔径(mm)Flow port dimension	d	-	-	12	15	20	28	32	40
重量(Kg) Weight		-	-	11	13.2	17.4	19	24.5	31

注: 如需法兰和阀体一体式锻造的请与TIANBANG销售人员联系。

Flange integrity Forged Steel Valve Enquiry Please Contact Sales Department.

螺栓连接阀盖, 全径, 明杆支架 (OS&Y), 末端连接为焊接法兰或对焊连接, 设计按Bs5352

Welded bonnet, full port outside screw and yoke(OS&Y), Flange-welded or but-welded ends; design to BS5352

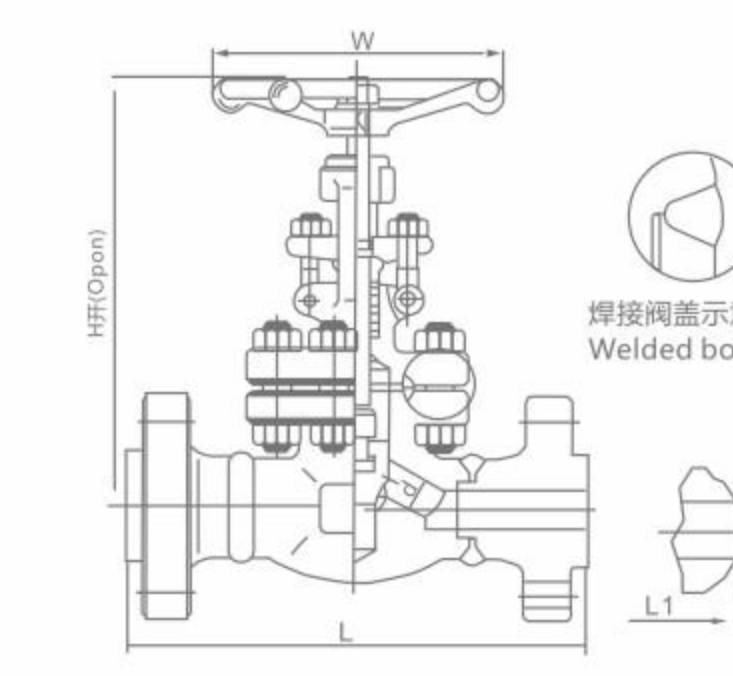

焊接阀盖示意图
Welded bonnet

CL2500

规格(NPS) Specification	F. P	1/4	3/8	1/2	3/4	1	1 1/4	1 1/2	2
结构长度(mm) Face to face	L(RF)L1(BW)	-	-	264	273	308	-	384	451
	L(RTJ)	-	-	264	273	308	-	387	454
手轮直径(mm) Handwheel diameter	W	-	-	125	160	200	-	250	240
中心高度(开)(mm)Height	H	-	-	207	240	258	-	355	300
流道孔径(mm)Flow port dimension	d	-	-	11	14	19	-	28	35
重量(Kg) Weight		-	-	19.5	21.5	42	-	65	95

螺栓连接阀盖 (RJ), 全径, 明杆支架 (OS&Y), 末端连接为焊接法兰或对焊连接, 设计按ASME B16.34

Welded bonnet, full port outside screw and yoke(OS&Y), Flange-welded or but-welded ends; design to ASME B16.34

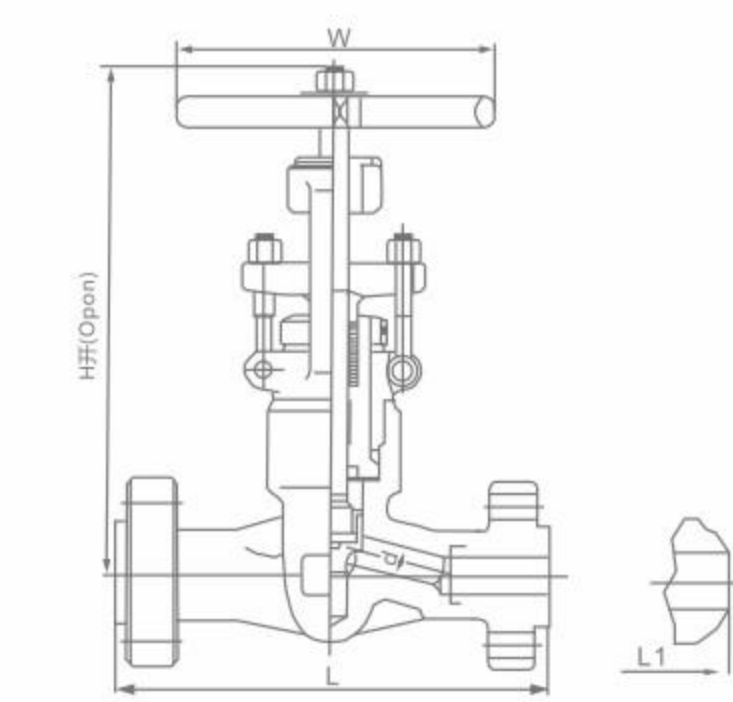

焊接阀盖示意图
Welded bonnet

CL2500

规格(NPS) Specification	F. P	1/4	3/8	1/2	3/4	1	1 1/4	1 1/2	2
结构长度(mm) Face to face	L(RF)L1(BW)	-	-	264	273	308	394	384	451
	L(RTJ)	-	-	264	273	308	394	387	454
手轮直径(mm) Handwheel diameter	W	-	-	200	200	280	280	280	300
中心高度(开)(mm)Height	H	-	-	320	320	320	440	440	490
流道孔径(mm)Flow port dimension	d	-	-	11	14	19	25	28	35
重量(Kg) Weight		-	-	21.5	24.7	30.4	48.1	58.1	130

压力自紧式密封闸阀, 全径, 明杆支架 (OS&Y), 末端连接为焊接法兰或对焊连接, 设计按ASME B16.34

Pressure seal gate valves, full port outside screw and yoke(OS&Y)

Flange-welded or but-welded ends; design to ASME B16.34

内螺纹与承插焊止回阀

Internal thread and socket weld check valve

CL800

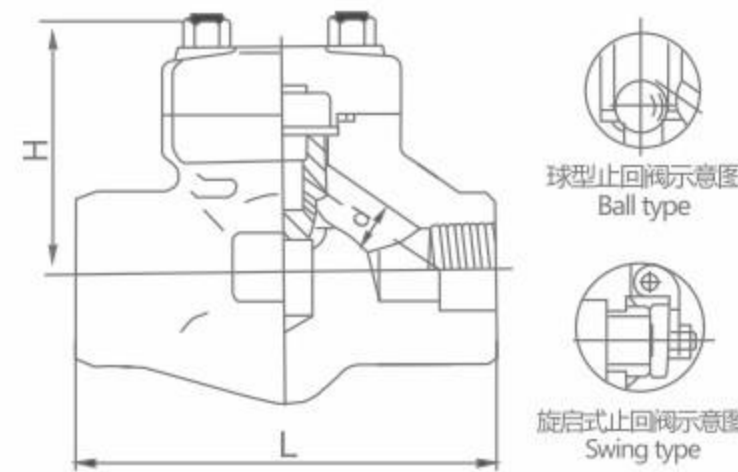

规格(NPS) Specification	F.P										
	R.P	1/4	3/8	1/2	3/4	1	1 1/4	1 1/2	2	2	
结构长度(mm) Face to face	L	升降式Lift	79	79	92	111	120	152	172	178	
		旋启式Swing	79	79	92	111	120	120	140	132	
中心高度(开)(mm)Height	H	升降式Lift	61	61	61	78	84	84	118	133	
		旋启式Swing	61	61	61	78	84	84	120	46	
流道孔径(mm)Flow port dimension	d	升降式Lift	7	9	13	17.5	23	30	35	45	
		旋启式Swing	8	10.5	13.5	18	24	29	36.5	12.5	
重量(Kg)Weight		升降式Lift	1.2	1.5	1.7	3.3	4.2	4.2	10.5	10.9	
		旋启式Swing	1.4	1.5	1.7	3.3	4.2	4.2	8.5		

螺栓连接阀盖, 缩径和全径, 末端连接为螺纹或承插焊或对焊, 设计按BS5352
Bolted bonnet, full port & reducing port, Threaded, but-welded or socket welded ends; design to BS5352

CL800

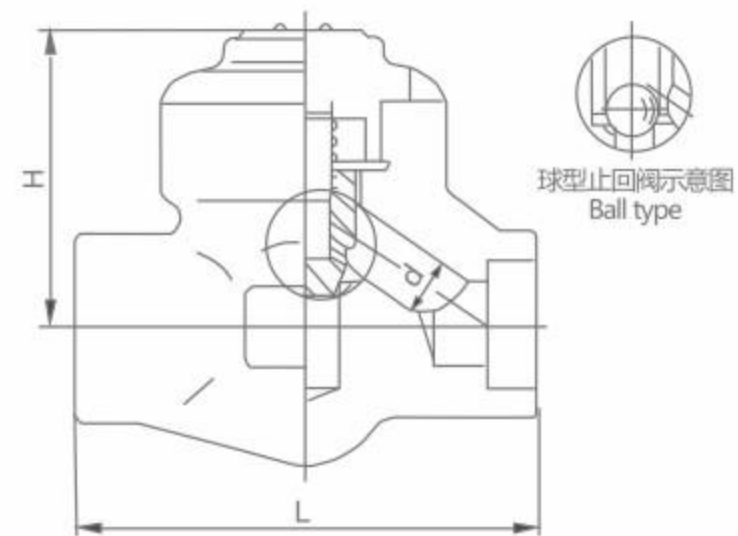

规格(NPS) Specification	F.P										
	R.P	1/4	3/8	1/2	3/4	1	1 1/4	1 1/2	2	2 1/2	
结构长度(mm) Face to face	L	79	79	92	111	120	152	172	200		
中心高度(开)(mm)Height	H	61	61	61	78	84	103	118	132		
流道孔径(mm)Flow port dimension	d	7	9	13	17.5	23	30	35	46		
重量(Kg)Weight		1.2	1.3	1.5	3.0	3.9	6.0	10	12		

螺栓连接阀盖, 缩径和全径, 末端连接为螺纹或承插焊或对焊, 设计按BS5352
Bolted bonnet, full port & reducing port, Threaded, but-welded or socket welded ends; design to BS5352

CL900-CL1500

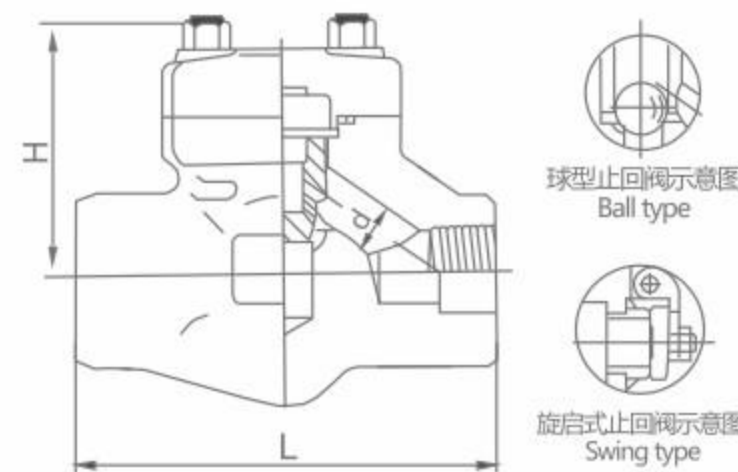

规格(NPS) Specification	F.P										
	R.P	1/4	3/8	1/2	3/4	1	1 1/4	1 1/2	2	2	
结构长度(mm) Face to face	L	升降式Lift	92	111	111	120	152	172	200		
		旋启式Swing	92	111	111	120	120	140	178		
中心高度(开)(mm)Height	H	升降式Lift	61	78	78	84	103	118	132		
		旋启式Swing	61	78	78	84	101	120	133		
流道孔径(mm)Flow port dimension	d	升降式Lift	7	12	15	20	28	32	40		
		旋启式Swing	8	10.5	13.5	18	24	29	45		
重量(Kg)Weight		升降式Lift	1.5	3.4	3.3	4.2	6.3	10.5	12.5		
		旋启式Swing	1.5	3.3	3.4	4.2	5.0	8.5	10.9		

螺栓阀盖, 缩径和全径, 末端连接为螺纹或承插焊, 设计按BS5352
Bolted bonnet, full port & reducing port, Threaded, but-welded or socket welded ends; design to BS5352

CL900-CL1500

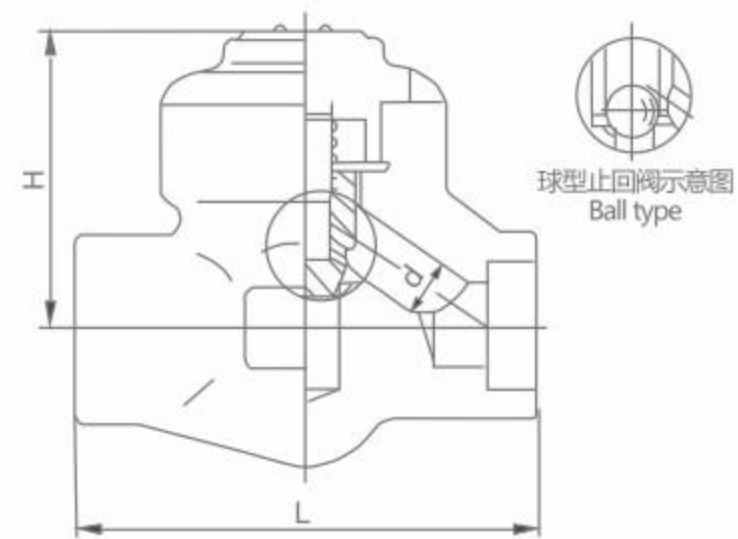

规格(NPS) Specification	F.P										
	R.P	1/4	3/8	1/2	3/4	1	1 1/4	1 1/2	2	2 1/2	
结构长度(mm) Face to face	L	92	111	111	120	152	172	200			
中心高度(开)(mm)Height	H	61	78	78	84	103	118	132			
流道孔径(mm)Flow port dimension	d	7	12	15	20	28	32	40			
重量(Kg)Weight		1.3	3.1	3.1	3.9	5.8	10.0	11.5			

螺栓阀盖, 缩径和全径, 末端连接为螺纹或承插焊, 设计按BS5352
Bolted bonnet, full port & reducing port, Threaded, but-welded or socket welded ends; design to BS5352

法兰与对焊止回阀

Flange and butt weld check valve

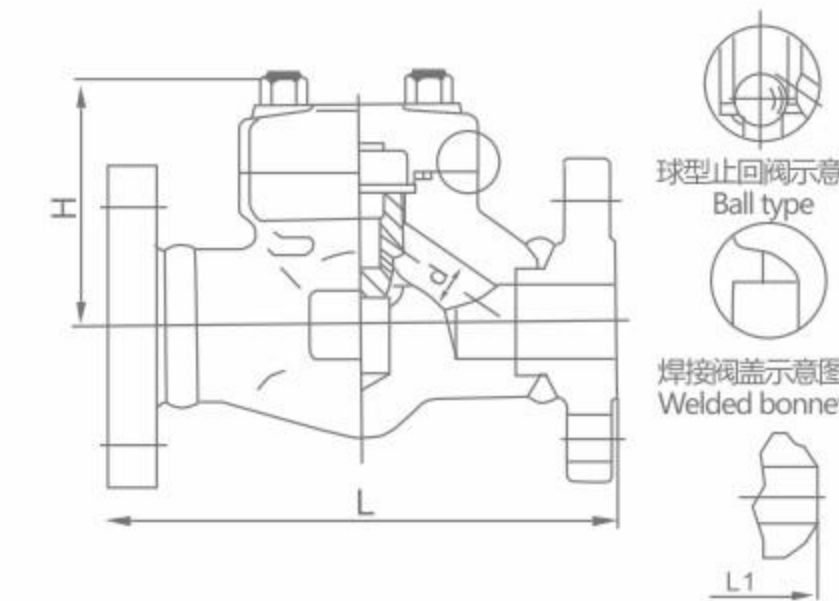

CL150-300-600

规格(NPS) Specification		R.P	1/4	3/8	1/2	3/4	1	1 1/4	1 1/2	2
结构长度(mm) Face to face	CL150	L(RF)	-	-	108	118	127	140	165	203
	CL300	L1(BW)	-	-	153	178	203	216	229	267
	CL600		-	-	165	191	216	229	241	292
中心高度(开)(mm)Height	CL150	H	-	-	77	81	93	95	103	118
	CL300/CL600		-	-	61	78	84	101	120	133
流道孔径(mm)Flow port dimension	d		-	-	10	13	17.5	23	30	35
重量(Kg)Weight	CL150	RF	-	-	3.6	4.6	8.5	9.2	12.5	14.8
		BW	-	-	3.0	3.6	7.6	8.5	11.3	13.6
	CL300	RF	-	-	3.7	4.8	8.8	9.6	13.7	17.8
		BW	-	-	3.2	4.3	8.0	8.6	12.7	16.2
	CL600	RF	-	-	4.0	5.8	9.5	10.4	15.6	24.5
		BW	-	-	3.4	5.1	8.8	9.2	14.8	22.5

螺栓阀盖, 缩径, 末端连接为法兰或对焊, 设计按 BS5352
Bolted bonnet reducing port, Flange-welded or but-welded ends; design to BS5352

CL150-300-600

规格(NPS) Specification		R.P	1/4	3/8	1/2	3/4	1	1 1/4	1 1/2	2
结构长度(mm) Face to face	CL150	L(RF)	-	-	108	118	127	140	165	203
	CL300	L1(BW)	-	-	153	178	203	216	229	267
	CL600		-	-	165	191	216	229	241	292
中心高度(开)(mm)Height	CL150	H	-	-	77	81	93	95	103	118
	CL300/CL600		-	-	61	78	84	101	120	133
流道孔径(mm)Flow port dimension	d		-	-	10.5	13.5	18	24	29	36.5
重量(Kg)Weight	CL150	RF	-	-	3.6	4.6	8.5	9.2	12.5	14.8
		BW	-	-	3.0	3.6	7.6	8.5	11.3	13.6
	CL300	RF	-	-	3.7	4.8	8.8	9.6	13.7	17.8
		BW	-	-	3.2	4.3	8.0	8.6	12.7	16.2
	CL600	RF	-	-	4.0	5.8	9.5	10.4	15.6	24.5
		BW	-	-	3.4	5.1	8.8	9.2	14.8	22.5

螺栓阀盖, 缩径, 末端连接为法兰或对焊, 设计按 BS5352
Bolted bonnet reducing port, Flange-welded or but-welded ends; design to BS5352

CL150-300-600

规格(NPS) Specification		R.P	1/4	3/8	1/2	3/4	1	1 1/4	1 1/2	2
结构长度(mm) Face to face	CL150	L(RF)	-	-	108	118	127	140	165	203
	CL300	L1(BW)	-	-	153	178	203	216	229	267
	CL600		-	-	165	191	216	229	241	292
中心高度(开)(mm)Height	CL150	H	-	-	77	81	93	95	103	118
	CL300/CL600		-	-	61	78	84	101	120	133
流道孔径(mm)Flow port dimension	d		-	-	10	13	17.5	23	30	35
重量(Kg)Weight	CL150	RF	-	-	3.2	3.5	4.6	5.2	7.0	16
		BW	-	-	2.8	3.0	4.0	4.6	6.3	15
	CL300	RF	-	-	4.6	6.1	9.1	12	16	21
		BW	-	-	4.1	5.7	8.4	11.2	14.5	19.5
	CL600	RF	-	-	4.8	6.3	9.3	13	16.5	22
		BW	-	-	4.4	5.9	8.7	12.1	15.8	20.8

螺栓阀盖, 缩径, 末端连接为法兰或对焊, 设计按 BS5352
Bolted bonnet reducing port, Flange-welded or but-welded ends; design to BS5352

CL150-300-600

规格(NPS) Specification		R.P	1/4	3/8	1/2	3/4	1	1 1/4	1 1/2	2
结构长度(mm) Face to face	CL150	L(RF)	-	-	108	118	127	140	165	203
	CL300	L1(BW)	-	-	153	178	203	216	229	267
	CL600		-	-	165	191	216	229	241	292
中心高度(开)(mm)Height	CL150	H	-	-	77	81	93	95	103	118
	CL300/CL600		-	-	61	78	84	101	120	133
流道孔径(mm)Flow port dimension	d		-	-	10.5	13.5	18	24	29	36.5
重量(Kg)Weight	CL150	RF	-	-	3.6	4.6	8.5	9.2	12.5	14.8
		BW	-	-	3.0	3.6	7.6	8.5	11.3	13.6
	CL300	RF	-	-	3.7	4.8	8.8	9.6	13.7	17.8
		BW	-	-	3.2	4.3	8.0	8.6	12.7	16.2
	CL600	RF	-	-	4.0	5.8	9.5	10.4	15.6	24.5
		BW	-	-	3.4	5.1	8.8	9.2	14.8	22.5

螺栓阀盖, 缩径, 末端连接为法兰或对焊, 设计按 BS5352
Bolted bonnet reducing port, Flange-welded or but-welded ends; design to BS5352

不锈钢法兰三通球阀

Stainless steel flange three way ball valve

Q44/644/944/45/645/945F-16C/P

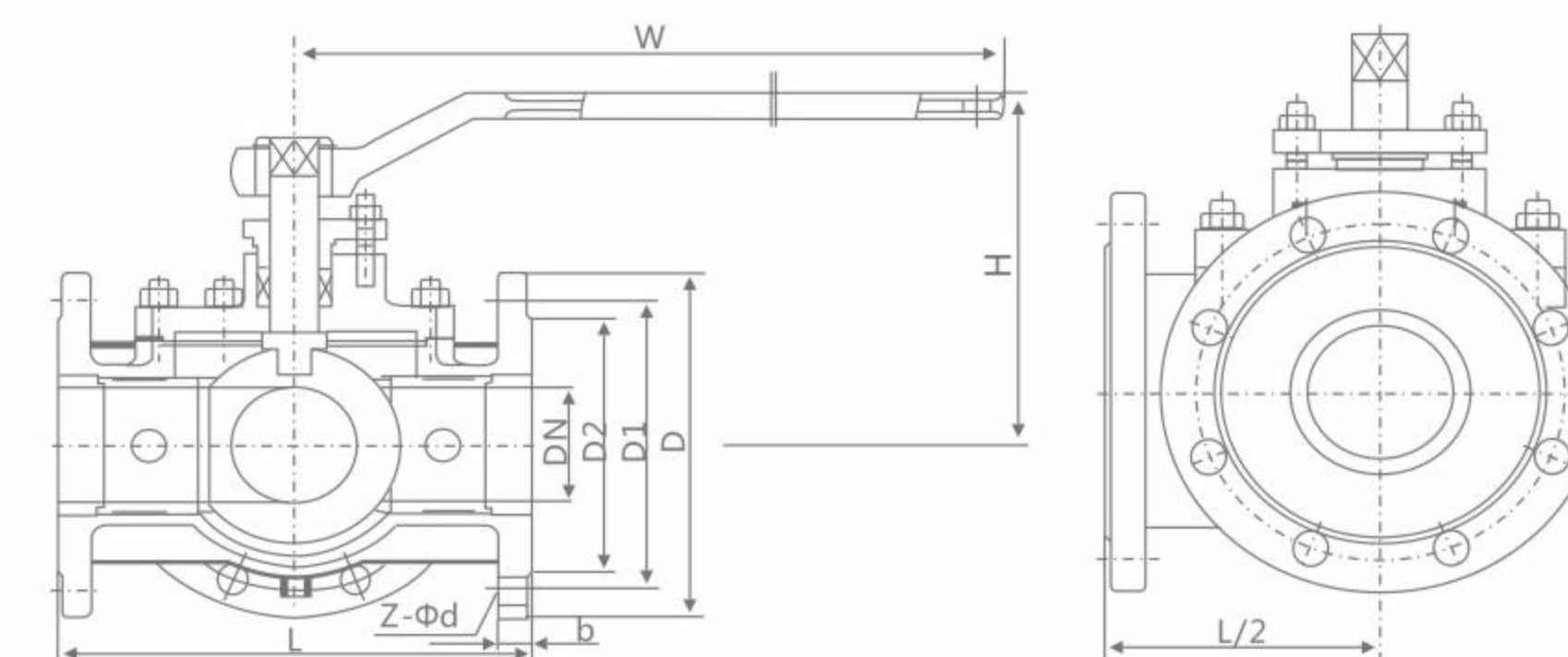

"L"型 L-type



"T"型 T-type

主要外形和连接尺寸 Main external and connection dimension

HG/T 20592

公称通径 DN	主要外形尺寸和连接尺寸(mm) Main external and connection dimensions								WT(kg)
	L	D	D1	D2	b	Z-φd	H	W	
	Q44F-16C Q44F-16P Q644F-16C Q644F-16P Q944F-16C Q944F-16P Q45F-16C Q45F-16P Q645F-16C Q645F-16P Q945F-16C Q945F-16P								
15	150	95	65	45	14	4-φ14	95	140	4
20	160	105	75	55	14	4-φ14	105	160	8
25	180	115	85	65	14	4-φ14	113	180	7
32	200	135	100	78	16	4-φ18	135	250	12
40	220	145	110	85	16	4-φ18	142	300	15
50	240	160	125	100	16	4-φ18	165	350	20
65	260	180	145	120	18	4-φ18	175	350	25
80	280	195	160	135	20	8-φ18	190	400	36
100	320	215	180	155	20	8-φ18	225	500	51
125	380	245	210	185	22	8-φ18	245	600	77
150	440	280	240	210	24	8-φ23	265	800	108
200	550	335	295	265	26	12-φ23	305	800	126
250	670	405	355	320	30	12-φ25	370	1300	185



06

RUITONG VALVE

其他阀门系列

OTHER VALVE SERIES

不锈钢法兰三通球阀

Stainless steel flange three way ball valve

主要外形和连接尺寸 Main external and connection dimension

HG/T 20592

公称通径 DN	主要外形尺寸和连接尺寸(mm) Main external and connection dimensions								WT(kg)
	L	D	D1	D2	D6	b	Z-Φd	H	
	Q44F-40 Q45F-40P Q644F-40 Q644F-40P Q944F-40 Q944F-40P Q45F-40 Q45F-40P Q644F-40 Q644F-40P Q944F-40 Q944F-40P								
15	150	95	65	45	16	4-Φ14	95	100	4
20	160	105	75	55	16	4-Φ14	105	160	5
25	180	115	85	65	16	4-Φ14	113	160	8
32	200	135	100	78	18	4-Φ18	135	250	13
40	220	145	110	85	18	4-Φ18	142	250	19
50	240	160	125	100	20	4-Φ18	154	350	27
65	260	180	145	120	22	8-Φ18	175	350	33
80	280	195	160	135	22	8-Φ18	190	450	40
100	320	230	190	160	24	8-Φ23	225	450	53
125	380	270	220	188	28	8-Φ25	245	600	86
150	440	300	250	218	30	8-Φ25	265	800	113
200	550	360	310	278	34	12-Φ25	305	1200	133
250	670	425	370	332	36	12-Φ30	370	1400	219

主要外形和连接尺寸 Main external and connection dimension

HG/T 20592

公称通径 DN	主要外形尺寸和连接尺寸(mm) Main external and connection dimensions								WT(kg)
	L	D	D1	D2	D6	b	Z-Φd	H	
	Q44F-40 Q45F-40P Q644F-40 Q644F-40P Q944F-40 Q944F-40P Q45F-40 Q45F-40P Q644F-40 Q644F-40P Q944F-40 Q944F-40P								
15	180	95	65	45	40	16	4-Φ14	100	4
20	190	105	75	55	51	16	4-Φ14	160	5
25	200	115	85	65	58	16	4-Φ14	160	8
32	210	135	100	78	66	18	4-Φ18	250	13
40	230	145	110	85	76	18	4-Φ18	250	19
50	250	160	125	100	88	20	4-Φ18	350	27
80	310	195	160	135	121	22	8-Φ18	450	40
100	350	230	190	160	150	24	8-Φ23	450	53
125	381	270	220	188	176	28	8-Φ25	600	86
150	403	300	250	218	204	30	8-Φ25	800	113
200	502	375	320	282	260	38	12-Φ30	1200	133
250	568	445	385	345	313	42	12-Φ34	1400	219

全焊接球阀

All welded ball valve

结构

阀门是由全焊的阀体和碳增强特氟隆密封垫组成，可以在频繁操作，有杂质及化学物质的情况下长寿命运行。研磨精细的不锈钢球体可以保证多年开闭自如，运行可靠。

采用浮球结构，斜面弹性垫圈保证密封圈紧压在球体之上，即使在压力不稳定的情况下，阀门可以保证严密。

阀杆的防泄漏结构适用两个“O”型圈，使阀杆转动自如且密封严密。

Structure

The valve is composed of a valve body welded and carbon reinforced Teflon gasket, in frequent operation, impurities and chemical substances under the condition of long service life. Grinding fine stainless steel ball can guarantee for many years to open and close, reliable operation.

Adopt floating ball structure, inclined plane elastic washer to ensure that the sealing ring is pressed on the ball, even in the case of unstable pressure, the valve can ensure tight.

The valve stem leakage structure using two "O"-shaped ring, so that the valve stem rotation and sealing.

特性

不需要维护，调整及润滑，易于安装，在低运行费用下长期可靠运行。阀杆可以加长、易于保温。

操作手柄可以拆下，换向安装。

阀体不含沉重且不可靠的铸件。

安装调节机构，非常简便。

Characteristic

Do not need to maintain, adjust and lubrication, easy to install, in the low operating cost of long-term reliable operation.

Valve stem can be lengthened, easy to heat insulation.

The operating handle can be removed and the reverse is installed.

The body does not contain heavy and unreliable castings.

Install regulator, very simple.

主要零件材料 Main components material

序号 No.	零件名称 Part name	材料 Material Science	
1	阀体 Body	碳钢 Carbon steel	ST37.8
2	阀杆室 Stem chamber	碳钢 Carbon steel	Fe52DP
3	球体 Ball	不锈钢 Stainless steel	AISI304
4	阀杆 Stem	不锈钢 Stainless steel	AISI303
5	密封圈 Seal ring	特氟隆 Teflon	PTFE
6	斜面垫圈 Bevel washer	弹簧钢 Spring steel	
7	支撑 Support	不锈钢 Stainless steel	
8	螺丝 Screw	钢 Steel	
9	O形密封圈 O-sealing ring	合成橡胶 Synthetic rubber	FPM
10	垫圈 Gasket	特氟隆 Teflon	PTFE
11	止退垫圈 Floor clip	铸钢 Cast steel	AISI304
12	手柄 Handle	镀锌钢 Galvanized steel	

结构图 Structure diagram

QW(3)4(6)1(7)F-16-40C

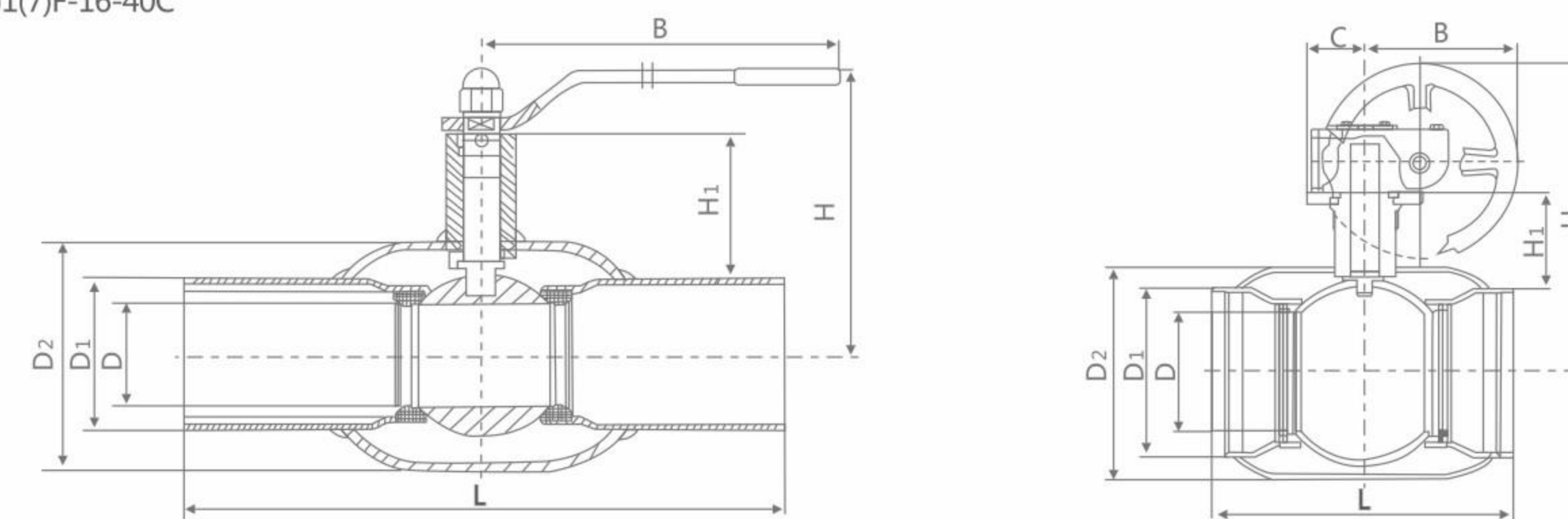

全焊接球阀 All welded ball valve

主要外形尺寸及连接尺寸 Main external and connection dimension

DN	PN	L	D	D1	D2	H	B	C	H1	
10	16	230	10	17.2	33.7	98	145	-	22	
15		230	10	21.3	33.7	98	145	-	22	
20		230	15	26.9	42.4	103	145	-	23	
25		230	20	33.7	48.3	118	145	-	34	
32		25	260	25	42.4	60.3	121	145	-	33
40		40	260	32	48.3	76.1	120	190	-	43
50		300	40	60.3	88.9	127	190	-	44	
65		300	50	76.1	114.3	170	280	-	71	
80	300	65	88.9	139.7	185	280	-	77		
100	16	325	80	114.3	168.3	210	280	-	102	
125		325	100	139.7	177.8	253	400	-	101	
150		350	125	168.3	219.1	273	600	-	107	
200		400	150	219.1	273	315	900	-	123	
250		530	200	273	355.6	398	1200	-	122	
300		550	250	323.9	457	465	280	193	155	
350		650	300	355.6	508	530	325	150	187	
400		760	350	406.4	610	530	466	175	221	
500		914	400	508	680	630	466	175	211	
600		1067	500	610	830	762	466	175	259	
700		1346	590	711	982	830	507	-	-	
800		1524	690	813	1086	910	624	-	-	
900	1727	790	914	1245	1025	844	-	-		
1000	1750	890	1016	1394	1165	881	-	-		
1200	2050	1190	1219	1576	1289	1092	-	-		

全焊接球阀 All welded ball valve

结构图 Structure diagram

QW(3)4(6)1(7)F-16-40C

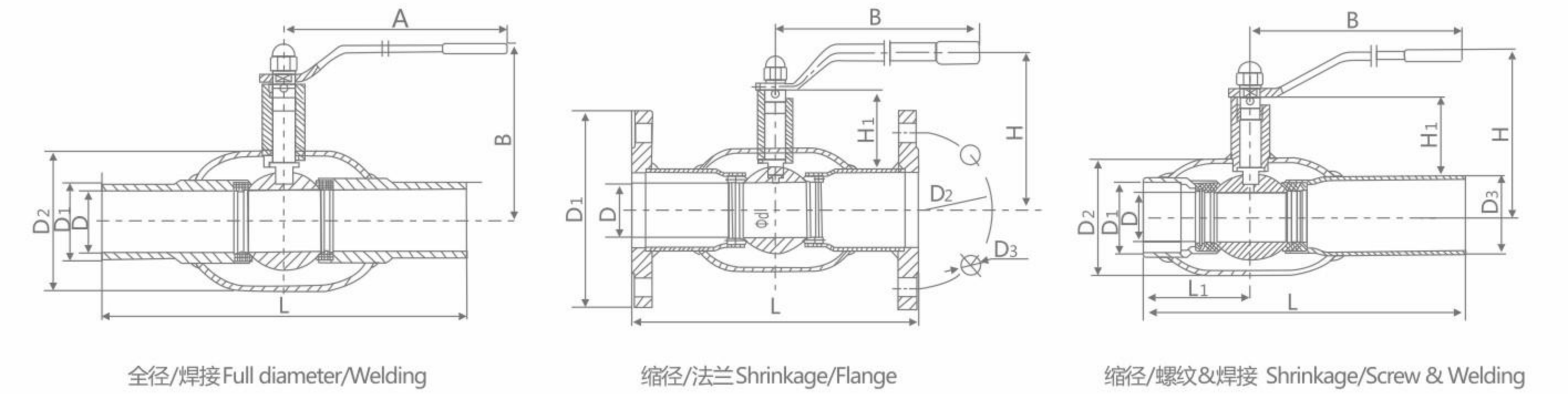

全径/焊接 Full diameter /Welding

DN	PN	L	D	D1	D2	A	H	B	H1
10	16	210	15	21.7	42.7	129	103	64	22
15		230	20	27.2	48	159	118	76	23
20		260	25	34.0	60	159	121	85	34
25		260	32	42.7	76	230	120	95	33
32		300	40	48.6	89	230	127	100	43
40		300	50	60.5	114	300	170	159	44
50		300	65	76.3	140	300	185	170	71
65		300	80	89.1	165	400	210	192	77
80	325	100	114.3	216	400	253	208	102	
100	350	125	139.8	219	450	273	241	101	
125	490	150	165.2	355	450	300	280	107	
150	580	200	216.3	356	252	325	500	123	
200	550	250	267.4	457	236	345	500	122	
250	630	300	318.5	508	331	465	600	155	
300	762	337	355.6	559	331	530	600	187	
400	840	387	406.4	660	360	550	700	221	
500	990	490	508.0	830	413	630	800	211	
600	1140	590	610	982	506	830	-	-	
700	1346	690	711	1086	605	910	-	-	
800	1524	790	813	1245	659	1025	-	-	
900	1727	890	914	1433	881	1165	-	-	
1000	1950	980	1016	1576	1092	1170	-	-	
1200	2250	1180	1219	1939	1092	1180	-	-	

DZ41Y低温闸阀

Low temperature gate valve

DZ41Y -16P

产品特点 Product features

- 1、为防止中腔异常升压，在闸板的进口侧设置了泄压孔
- 2、根据阀门的工作温度确定阀盖的顶部长度，确保阀杆填料的可靠密封
- 3、根据工作温度合理选用填料，垫片等零件的材料
- 4、严格控制填料的化学成分及低温冲击韧性等力学性能指标
- 5、采用多种配管法兰标准及密封面型式，适用于各种工程需要6低温闸阀适用于甲烷、液态天然气、乙烯、二氧化碳、液氨、液氧、液氮、液氢等低温介质

产品优点 Product advantages

- 1、流体阻力小，密封面受介质的冲刷和侵蚀小。
- 2、开闭较省力。
- 3、介质流向不受限制，不扰流、不降低压力。
- 4、形体简单，结构长度短，制造工艺性好，适用范围广。

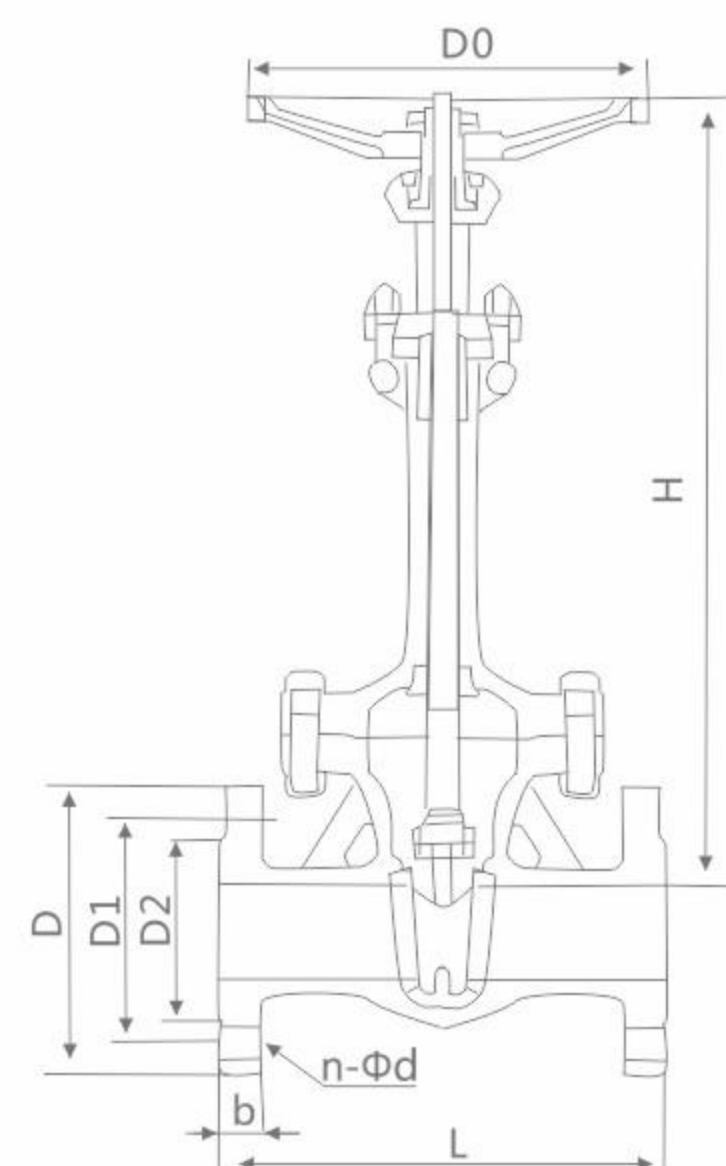

执行标准 Execution standard

设计与制造 Design and Manufacture	结构长度 Structure Length	法兰尺寸 Connection flange	压力-温度 Pressure-temperature rating	试验-检验 Test and Inspection
JB/T7749	GB12221	JB79	GB9131	JB/T9092

压力试验 Pressure test

公称压力PN	1.6	2.5	4.0	6.4	10.0
强度试验 Strength test	2.4	3.8	6.0	9.6	15.0
水密封试验 Water sealing test	1.8	2.8	4.4	7.0	11.0
上密封试验 Back Seal test	1.8	2.8	4.4	7.0	11.0
气密封试验 Air tightness test	0.4-0.7				

主要零件材料及性能 Major parts material and the performance

体盖板 Body cover plate	阀杆 Valve stem	密封面 Sealing surface	垫片 Shim	填料 Filler	工作温度 Operation temperature	适用介质 Applicable Medium
ZGoCrMnVA(低温高压铸钢)	1Cr7Ni12	STL/STL	PTFE/柔性石墨	PTFE	-46	丙烷/炳烯 甲醇/乙烷 煤气/液氨 Propane/Bingene Methanol/Ethane Gas/liquid ammonia
LCB					-60	
ZGoCrMnVA(低温高压铸钢)					-73	
LC1					-101	
ZGoCrMnVA(低温高压铸钢)	1Cr18Ni9Ti	STL/STL	PTFE/金属缠绕垫 PTFE/flexible graphite PTFE/metal wound gasket	PTFE	-115	丙烷/炳烯 甲醇/乙烷 煤气/液氨 Propane/Bingene Methanol/Ethane Gas/liquid ammonia
LC2					-196	
ZGoCrMnVA(低温高压铸钢)					-115	
LC3					-196	
ZGoCrMnVA(低温高压铸钢)	1Cr18Ni9Ti	STL/STL	PTFE/金属缠绕垫 PTFE/flexible graphite PTFE/metal wound gasket	PTFE	-115	丙烷/炳烯 甲醇/乙烷 煤气/液氨 Propane/Bingene Methanol/Ethane Gas/liquid ammonia
LC4					-196	
ZGoCrMnVA(低温高压铸钢)	1Cr18Ni9Ti	STL/STL	PTFE/金属缠绕垫 PTFE/flexible graphite PTFE/metal wound gasket	PTFE	-115	丙烷/炳烯 甲醇/乙烷 煤气/液氨 Propane/Bingene Methanol/Ethane Gas/liquid ammonia
CF8					-196	

DZ41H/Y/F低温闸阀

Low temperature gate valve

主要外形尺寸及连接尺寸 Main external and connection dimension

PN16(MPa)

DN	L	D	D1	D2	b	n-φd	H	DO
20	150	105	75	55	14	4-φ14	320	140
25	160	115	85	65	14	4-φ14	350	160
32	180	135	100	78	16	4-φ18	385	180
40	200	145	110	85	16	4-φ18	420	220
50	250	160	125	100	16	4-φ18	540	240
65	265	180	145	120	18	4-φ18	610	240
80	280	195	160	135	20	8-φ18	690	280
100	300	215	180	155	20	8-φ18	780	300
125	325	245	210	185	22	8-φ18	930	320
150	350	280	240	210	24	8-φ23	980	350
200	400	335	295	265	26	12-φ26	1180	400
250	450	405	355	320	30	12-φ30	1390	450
300	500	460	410	375	30	12-φ30	1620	500
350	550	520	470	435	34	16-φ34	1810	500
400	600	580	525	485	36	16-φ36	1970	550

PN25(MPa)

DN	L	D1	D1	D2	b	N-φd	H	DO
20	150	105	75	55	16	4-φ16	320	140
25	160	115	85	65	16	4-φ16	350	160
32	180	135	100	78	18	4-φ18	385	180
40	200	145	110	85	18	4-φ18	420	200
50	250	160	125	100	20	4-φ20	540	240
65	265	180	145	125	22	8-φ22	510	240
80	280	195	160	135	22	8-φ22	690	280
100	300	230	190	160	24	8-φ24	780	300
125	325	270	220	188	28	8-φ28	930	300
150	350	300	250	218	30	8-φ30	980	320
200	400	360	310	278	34	12-φ34	1180	360
250	450	425	370	332	36	12-φ36	1390	400
300	500	485	430	390	40	16-φ40	1620	450
350	550	550	490	448	44	16-φ44	1810	500
400	600	610	550	505	48	16-φ48	1990	560

DZ41H/Y/F低温闸阀

Low temperature gate valve

主要外形尺寸及连接尺寸 Main external and connection dimension

PN40(MPa)

DN	L	D	D1	D2	D6	b	N-Φd	H	Do
20	150	105	75	55	51	16	4-Φ14	330	140
25	160	115	85	65	58	16	4-Φ14	360	160
32	180	135	100	78	66	18	4-Φ18	440	180
40	200	145	110	85	76	18	4-Φ18	455	200
50	250	160	125	100	88	20	4-Φ18	575	240
65	380	180	145	120	110	22	4-Φ20	635	240
80	3103	195	160	135	121	22	8-Φ22	715	280
100	50	230	190	160	150	24	8-Φ22	815	300
125	400	270	220	188	176	28	8-Φ24	965	360
150	450	300	250	218	204	30	8-Φ28	1025	400
200	550	375	320	282	160	38	8-Φ30	1225	450
250	650	445	385	345	313	42	12-Φ34	1440	560
300	750	510	450	408	364	46	16-Φ34	1665	5470
350	850	570	510	465	422	52	16-Φ41	1880	720
400	950	655	585	535	474	58	16-Φ18	2050	800

PN64(MPa)

DN	L	D	D1	D2	D6	b	N-Φd	H	Do
20	190	125	90	68	51	20	4-Φ18	330	180
25	210	135	100	78	58	22	4-Φ23	360	180
32	230	150	110	82	66	24	4-Φ23	410	180
40	240	165	125	95	76	24	4-Φ23	480	220
50	250	175	135	105	88	26	4-Φ23	585	240
65	280	200	160	130	110	28	8-Φ23	690	240
80	310	210	170	140	121	30	8-Φ23	745	280
100	350	250	200	168	150	32	8-Φ25	885	300
125	400	295	240	202	176	36	8-Φ30	985	360
150	450	340	280	240	204	38	8-Φ34	1050	400
200	550	405	345	300	260	44	12-Φ34	1240	450
250	650	470	400	352	313	48	12-Φ41	1460	560
300	750	530	160	412	364	54	16-Φ41	1670	5640

DJ41F-16/40P低温截止阀

Low temperature globe valve

DJ41F-16/40P

产品规范

公称压力：1.6MPa
公称通径：10mm~200mm
适用介质：L02、LN2、LAr、LNG、LC2H4等
适用温度：-196~+80℃
连接方式：法兰
介质流向：由阀瓣下面向上流

Product specification

Nominal pressure: 1.6 MPa
Nominal size: 10 mm to 200 mm
Applicable medium: L02, LN2, LAr, LNG, LC2H4, etc
Applicable temperature: 196 ~ + 80 °C
Connection mode: flange
Under the medium flow direction: the disc for high

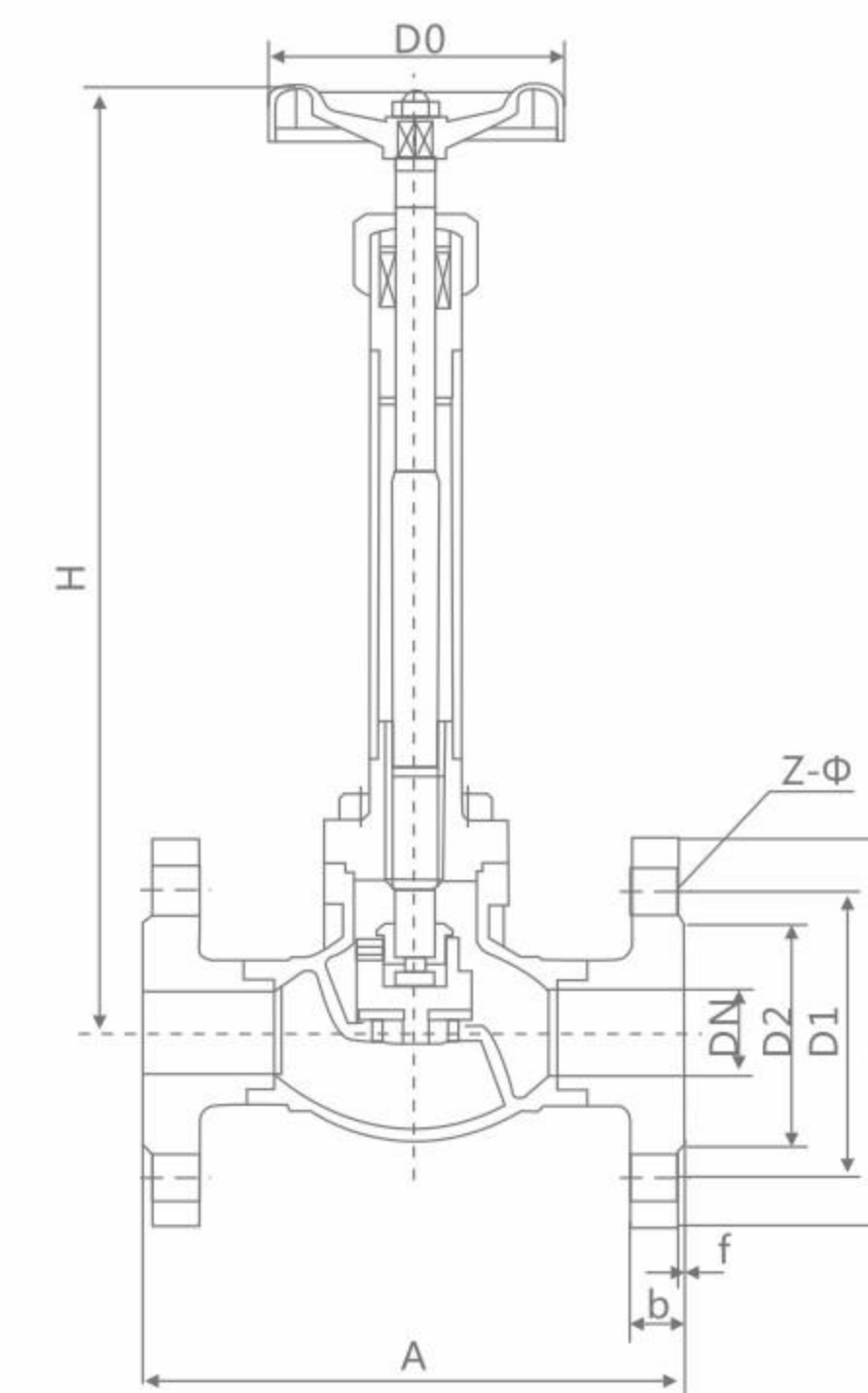

主要外形和连接尺寸 Main external and connection dimension

产品代号	通径 DN (mm)	主要连接尺寸 Main connecting dimensions										重量 (kg)
		A	H1	H2	D	D1	D2	Z-Φd	b	f	Do	
222J10AB2A3	10	130	253	247	90	60	40	4-14	16	2	75	3.2
222J15AB2A3	15	130	268	260	95	65	45	4-14	16	2	75	3.8
222J20AB2A3	20	150	307	297	105	75	55	4-14	16	2	100	5.5
222J25AB2A3	25	160	323	310	115	85	65	4-14	16	2	100	5.9
222J32AB2A3	32	180	362	346	135	100	78	4-18	18	2	120	7.1
222J40AB2A3	40	200	380	360	145	110	85	4-18	18	2	120	11.2
222J50AB2A3	50	230	445	420	160	125	100	4-18	20	3	160	17.5
222J65AB2A3	65	290	473	440	180	145	120	8-18	20	3	200	18.4
222J80AB2A3	80	310	510	470	195	160	135	8-18	22	3	240	30.1
222J100AB2A3	100	350	589	539	215	180	155	8-18	22	3	280	40.2
222J125AB2A3	125	400	665	602	245	210	185	8-18	24	3	300	53.9
222J150AB2A3	150	480	713	638	280	240	210	8-23	26	3	350	68.3
222J200AB2A3	200	600	805	705	375	295	265	12-23	30	3	400	134.2
222J250AB2A3	250	650	985	860	405	355	320	12-25	32	3	550	248.7
222J300AB2A3	300	750	1080	930	460	410	370	12-25	34	4	650	334.5

DH41F-40P低温止回阀

Low temperature check valve

DH41F-40P

产品规范

公称压力: 4.0Mpa
设计温度: -196°C ~ +80°C
适用介质: LNG、LO₂、LN₂、LAr、CO₂
连接方式: 承插焊

Product specification

Nominal pressure: 4.0 Mpa
Design temperature: -196 °C ~ + 80 °C
Applicable medium: LNG, LO₂, LN₂, LAr, CO₂
Connection mode: socket welding

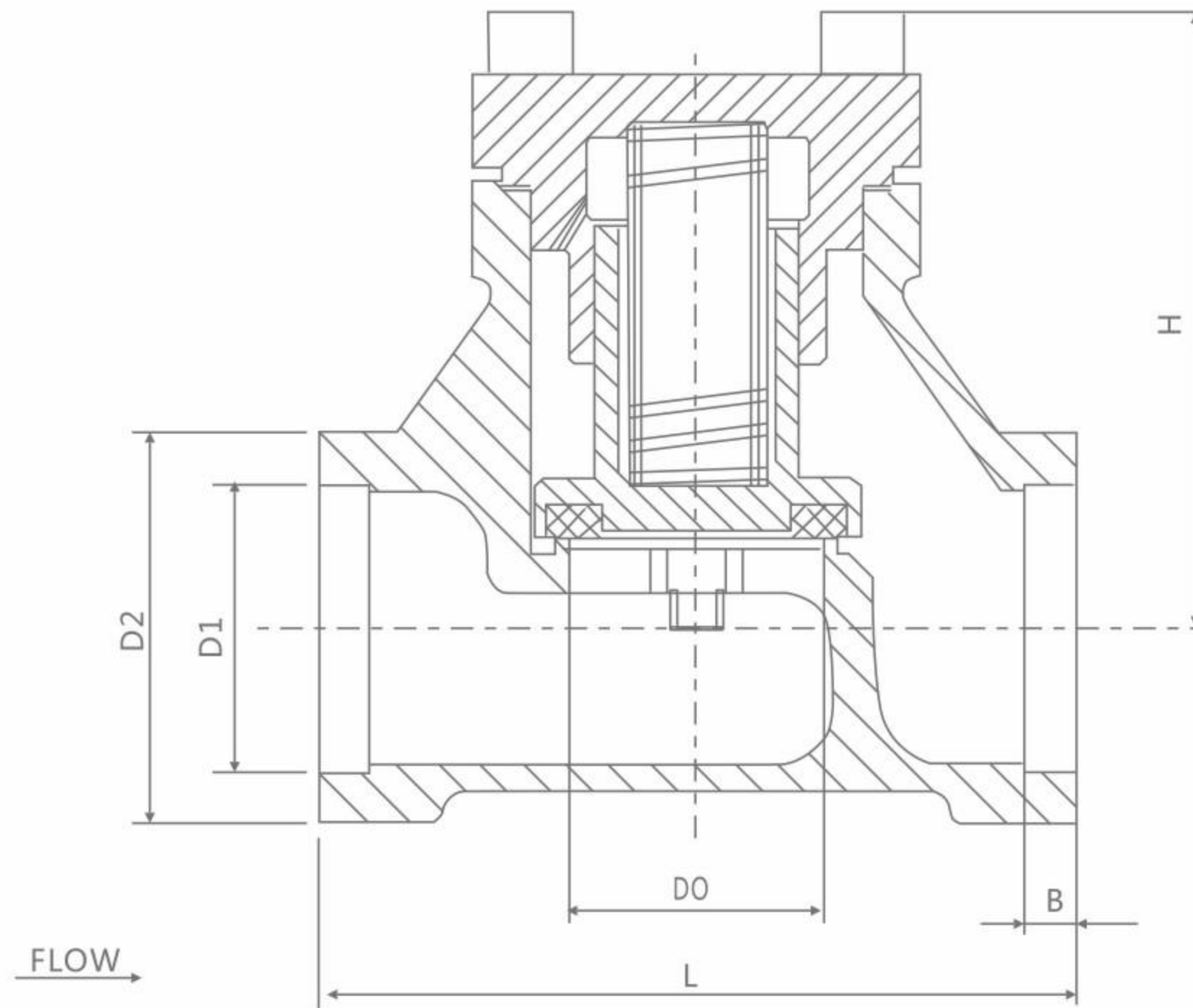

型号 Type	主要外形连接尺寸(mm) Major Overall & Connection Dimensions					
	H	L	D0	D1	D2	B
DH-10	55	60	Φ13	Φ14.5	Φ24	6
DH-15	62	65	Φ15	Φ18.5	Φ29.5	6
DH-20	70	80	Φ20	Φ25.5	Φ36	8
DH-25	77	90	Φ25	Φ32.5	Φ43.5	8
DH-32	89	105	Φ32	Φ38.5	Φ53	8
DH-40	98	120	Φ40	Φ45.5	Φ62	8
DH-50	111	140	Φ50	Φ57.5	Φ72	10



07

RUITONG
VALVE

过滤器系列

FILTER
SERIES

美标Y型过滤器 API Y-type strainer

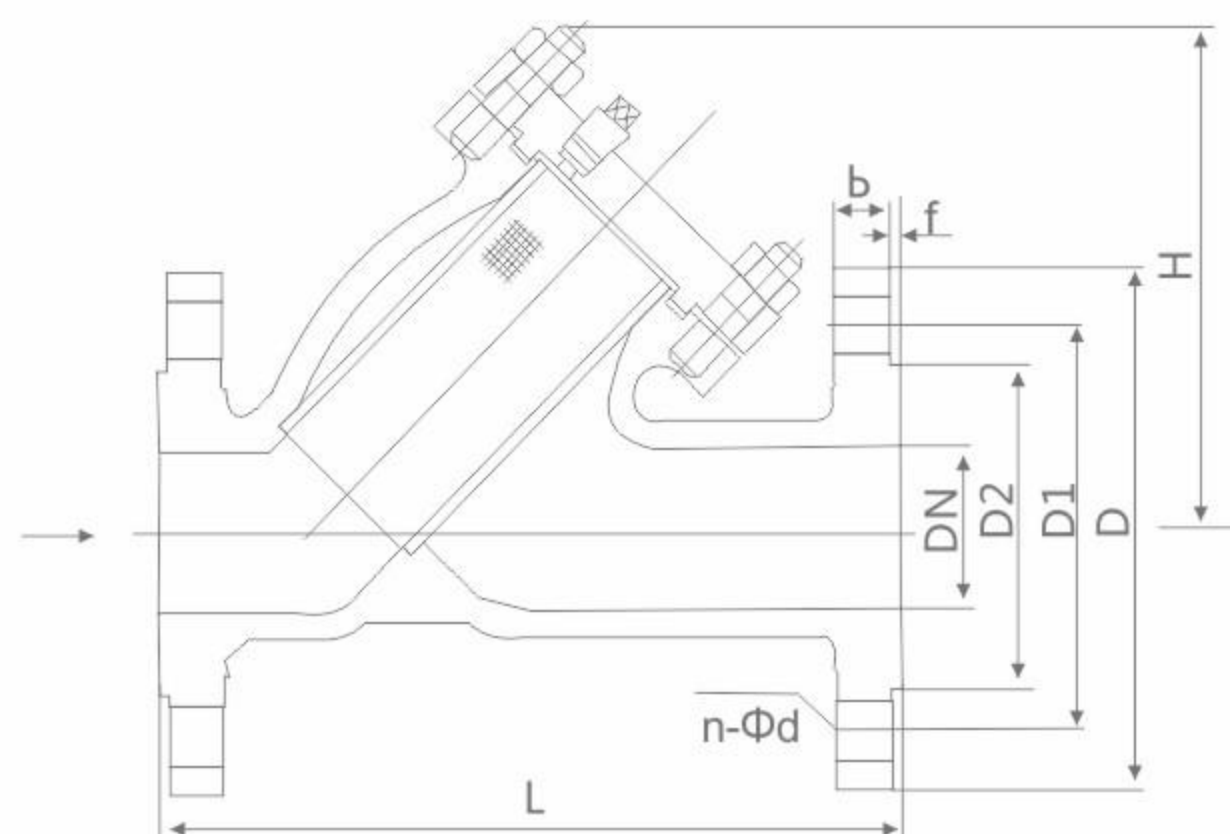

CLASS 300Lb/300LbP/300LbR 美标Y型过滤器

DN		L	D	D1	D2	b	f	n-Φd	H
mm	in								
15	1/2"	130	95	66.7	34.9	14.7	2	4-16	102
20	3/4"	145	115	82.6	42.9	16.3	2	4-19	113
25	1"	150	125	88.9	50.8	17.9	2	4-19	143
32	1-1/4"	180	135	98.4	63.5	19.5	2	4-19	166
40	1-1/2"	200	155	114.3	73	21.1	2	4-22	184
50	2"	220	165	127	92.1	22.7	2	8-19	213
65	2-1/2"	250	190	149.2	104.8	25.9	2	8-22	303
80	3"	280	210	168.3	127	29	2	8-22	328
100	4"	300	255	200	157.2	32.2	2	8-22	385
125	5"	350	280	235	185.7	35.4	2	8-22	465
150	6"	380	320	269.9	215.9	37	2	12-22	530
200	8"	480	380	330.2	269.9	41.7	2	12-26	665
250	10"	550	445	387.4	323.8	48.1	2	16-29	720
300	12"	610	520	450.8	381	51.3	2	16-32	805
350	14"	680	585	514.4	412.8	54.4	2	20-32	862
400	16"	780	650	571.5	469.9	57.6	2	20-35	908
450	18"	850	710	628.6	533.4	60.8	2	24-35	929
500	20"	900	775	685.8	584.2	64	2	24-35	1000
600	24"	1125	915	812.8	692.2	70.3	2	24-41	1200

CLASS 600Lb/600LbP/600LbR 美标Y型过滤器

DN		L	D	D1	D2	b	f	n-Φd	H
mm	in								
15	1/2"	130	95	66.7	34.9	21.3	7	4-16	102
20	3/4"	145	115	82.6	42.9	22.9	7	4-19	113
25	1"	150	125	88.9	50.8	24.5	7	4-19	143
32	1-1/4"	180	135	98.4	63.5	27.7	7	4-19	166
40	1-1/2"	200	155	114.3	73	29.3	7	4-22	184
50	2"	220	165	127	92.1	32.4	7	8-19	213
65	2-1/2"	250	190	149.2	104.8	35.6	7	8-22	303
80	3"	280	210	168.3	127	38.8	7	8-22	328
100	4"	300	275	215.9	157.2	45.1	7	8-26	385
125	5"	350	330	266.7	185.7	51.5	7	8-29	465
150	6"	380	355	292.1	215.9	54.7	7	12-29	530
200	8"	480	420	349.2	269.9	62.6	7	12-32	665
250	10"	550	510	431.8	323.8	70.5	7	16-35	720
300	12"	610	560	489	381	73.7	7	20-35	805
350	14"	680	605	527	412.8	76.9	7	20-38	862
400	16"	780	685	603.2	469.9	83.2	7	20-41	908
450	18"	850	745	654	533.4	89.6	7	20-45	929
500	20"	900	815	723.9	584.2	95.9	7	24-45	1000
600	24"	1125	940	838.2	692.2	108.6	7	24-51	1200

日标Y型过滤器 JIS Y-Type Strainer

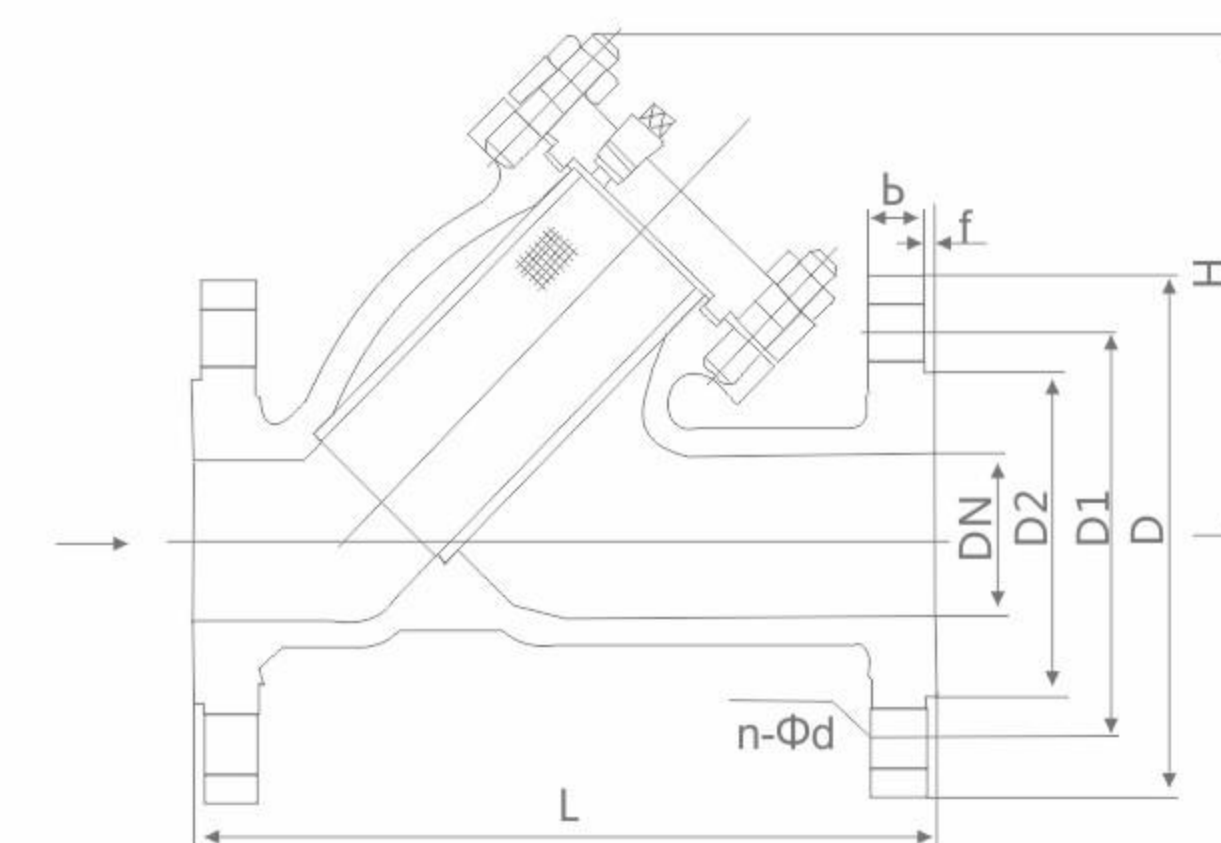

GL41W-10K, GL41H-10K 日标Y型过滤器

DN		L	D	D1	D2	b	n-Φd
mm	in						
15	1/2"	130	95	70	52	12	4-15
20	3/4"	145	100	75	58	14	4-15
25	1"	150	125	90	70	14	4-19
32	1-1/4"	180	135	100	80	16	4-19
40	1-1/2"	200	140	105	85	16	4-19
50	2"	220	155	120	100	16	4-19
65	2-1/2"	250	175	140	120	18	4-19
80	3"	280	185	150	130	18	8-19
100	4"	300	210	175	155	18	8-19
125	5"	350	250	210	185	20	8-23
150	6"	380	280	240	215	22	8-23
200	8"	480	330	290	265	22	12-23
250	10"	500	400	355	325	24	12-25
300	12"	610	445	400	390	24	12-25

GL41W-20K, GL41H-20K 日标Y型过滤器

DN		L	D	D1	D2	b	n-Φd
mm	in						
15	1/2"	130	95	70	52	12	4-15
20	3/4"	145	100	75	58	14	4-15
25	1"	150	125	90	70	14	4-19
40	1-1/2"	200	140	105	85	16	4-19
50	2"	220	155	120	100	18	8-19
65	2-1/2"	250	175	140	120	20	8-19
80	3"	280	200	160	135	22	8-23
100	4"	300	225	185	160	24	8-23
125	5"	350	270	225	195	26	8-25
150	6"	380	305	260	230	28	12-25
200	8"	480	350	305	275	30	12-25
250	10"	500	430	380	345	34	12-27
300	12"	610	480	430	395	35	16-27

国标Y型过滤器 GB Y type filter

GL41W-16C/P/R

基本参数

介质温度：300(°C)
工作压差：2KG
材质：不锈钢
产品别名：Y型过滤器
适用范围：液体过滤
连接形式：法兰
类型：直角式
流动方向：单向
适用介质：水
压力环境：常压

Basic parameters

Medium temperature: 300 °C
Working pressure difference: 2 kg
Material: stainless steel
Product alias: Y type filter
Scope of application: liquid filtration
Connection: flange
Type: the right Angle
Flow direction: one way
Applicable medium: water
Pressure: the atmospheric pressure

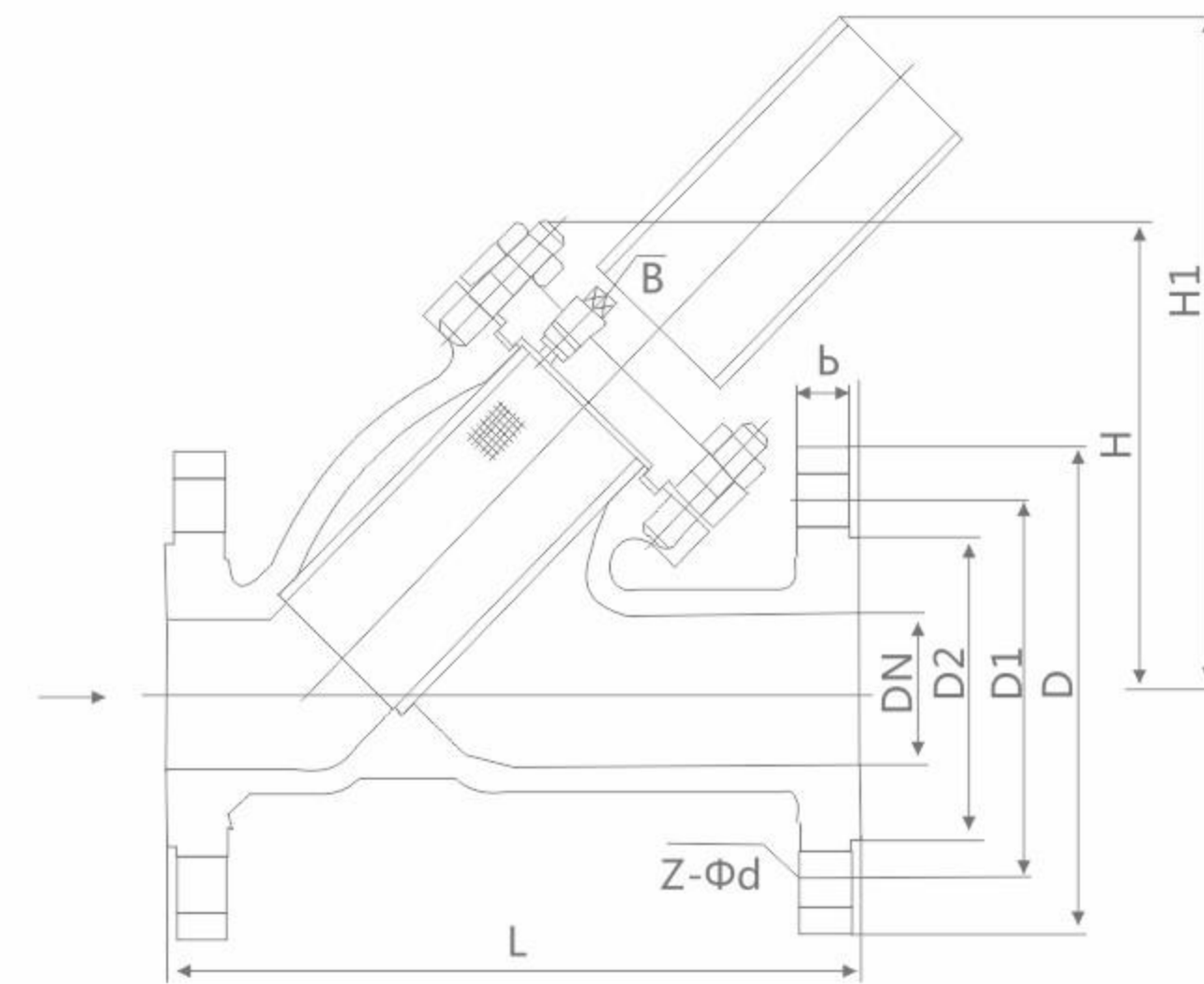

主要外形和连接尺寸 Main external and connection dimension

公称压力 PN(MPa)	公称口径 DN(mm)	尺寸(mm)						
		L	D	D1	D2	b	Z-φd	H
1.6MPa	15	130	95	65	45	14-2	4-φ14	60
	20	145	105	75	55	14-2	4-φ14	70
	25	150	115	85	65	14-2	4-φ14	70
	32	180	135	100	78	16-2	4-φ18	75
	40	200	145	110	85	16-3	4-φ18	90
	50	220	160	125	100	16-3	4-φ18	105
	65	250	180	145	120	18-3	4-φ18	150
	80	280	195	160	135	20-3	8-φ18	175
	100	300	215	180	155	20-3	8-φ18	200
	125	350	245	210	185	22-3	8-φ18	205
	150	380	280	240	210	24-3	8-φ23	260
	200	480	335	295	265	26-3	12-φ23	300
250	550	405	355	320	30-3	12-φ25	380	
300	610	460	410	375	30-4	12-φ25	410	

T型过滤器 T type filter

ST 16C/ST34C-J16~J50

产品概述 Products overview :

T型过滤器是除去液体中少量固体颗粒的小型设备，可保护设备的正常工作，当流体进入置有一定规格滤网的滤筒后，其杂质被阻挡，而清洁的滤液则由过滤器出口排出，当需要清洗时，只要将可拆卸的滤筒取出，处理后重新装入即可，因此，使用维护极为方便。

技术参数 Technical parameters :

- 1、工作温度：≤90°C
- 2、公称口径：DN25—DN600mm
- 3、公称压力：PN≤1.6Mpa（其它工作压力可按用户要求设计）
- 4、法兰标准：GB81-59（也可按用户要求制造）
- 5、壳体材质：A3、304、304L、316、316L
- 6、密封材料：聚四氟乙烯、丁腈橡胶、耐油石棉胶

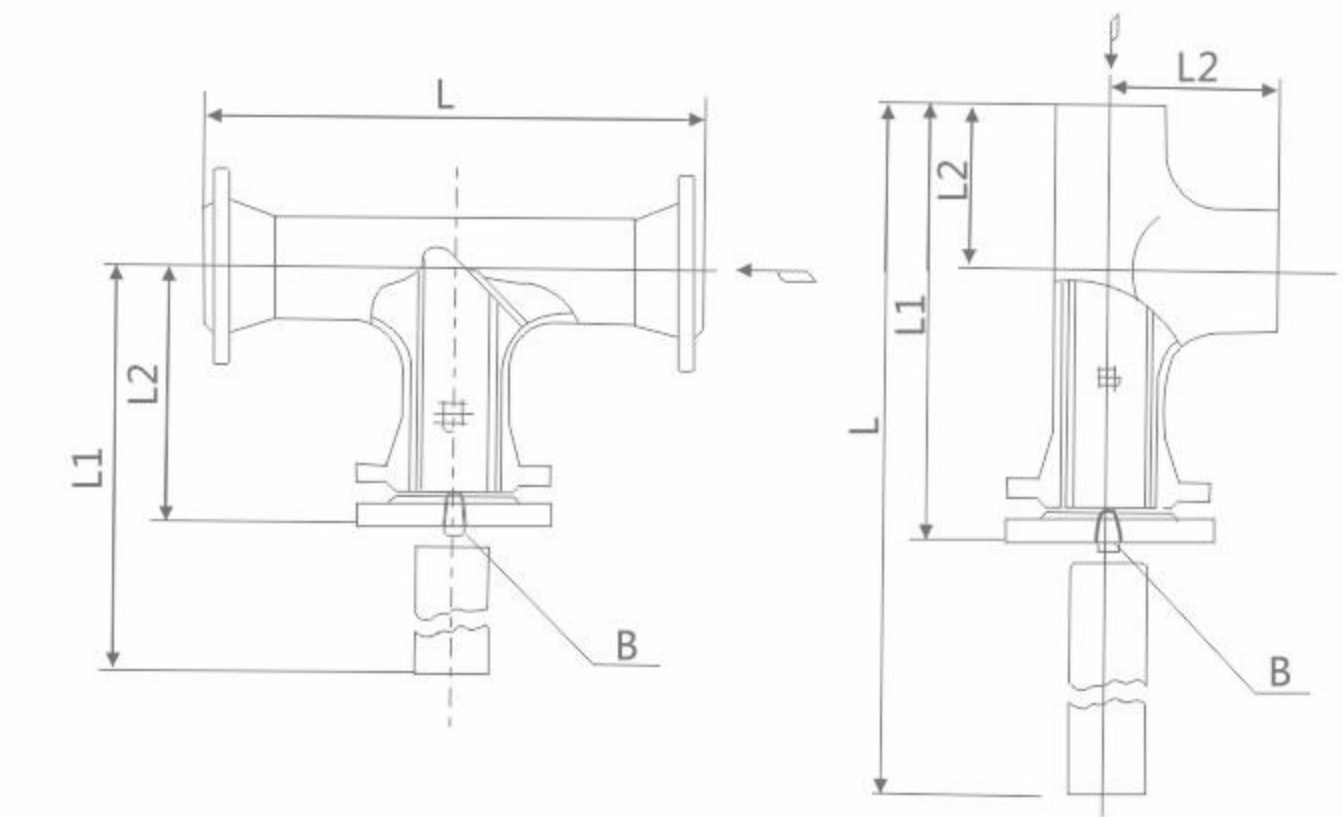

主要外形和连接尺寸 Main external and connection dimension

单位Unit:mm

公称口径 DN	L	L1	L2	B1排放口Blowdown Tap			有效过滤面积 Strainer Area (m2)	WT (Kg)
				I	II	III		
ST34C-J16 ST-34C-J25 ST34C-J34C ST34C-J20 ST34C-J50								
50	268	298	158	R3/8 "	DN20 平面 RF	DN20 凸面 M	0.00277	13.6
65	304	337	179				0.00421	18.9
80	330	370	195.5				0.00552	24
100	382	432	225				0.0088	36
150	482	557	280				0.01696	68
200	578	678	332.5				0.0355	140
250	66	791	383				0.0529	216
300	768	918	437				0.0686	315

主要外形和连接尺寸 Main external and connection dimension

单位Unit:mm

公称口径 DN	L	L1	L2	B1排放口Blowdown Tap			有效过滤面积 Strainer Area (m2)	WT (Kg)
				I	II	III		
ST16C-J16 ST-16C-J25 ST16C-J40 ST16C-J20 ST16C-J50								
50	402	222	64	R1/2 "	DN20 平面 RF	DN20 凸面 M	0.00387	8
65	469	255	76				0.00592	12
80	512	282	89				0.00811	15
100	590	330	105				0.013	23
150	773	423	143				0.026	47
200	951	510	178	R3/4 "			0.0459	98
250	1099	599	216				0.0706	154
300	1291	691	254				0.0942	232

法兰参数对照表

Flange parameters comparison table

表1 PN0.6MPa (6压力) 板式平焊钢制管法兰 mm

公称 口径 DN	管子外径 A1		连接尺寸					密封面尺寸		法兰 厚度 C	法兰内径 B1		坡口 宽度 b	法兰理论 重量系列 Z kg
	国际 A管	国内 B管	法兰外径 系列1/系列2 D	螺栓孔 中心圆 直径K	螺栓孔直径 系列1/系列2 L	螺栓、螺柱					A	B		
						数量n	螺纹Th. 系列1/系列2	d	f					
10	17.2	14	75	50	12	4	M10	32	2	12	18	15	3	0.32
15	21.3	18	80	55	12	4	M10	40	2	12	22	19	3	0.34
20	26.9	25	90	65	12	4	M10	50	2	14	27.5	26	3	0.54
25	33.7	32	100	75	12	4	M10	60	2	14	34.5	33	4	0.64
32	42.4	38	120	90	14	4	M12	70	2	16	43.5	39	4	1.10
40	48.3	45	130	100	14	4	M12	80	3	16	49.5	46	4	1.22
50	60.3	57	140	110	14	4	M12	90	3	16	61.5	59	4	1.35
65	76.1	76	160	130	14	4	M12	110	3	16	77.5	78	5	1.67
80	88.9	89	190/185	150	18	4	M16	125	3	18	90.5	91	5	2.48
100	114.3	108	210/205	170	18	4	M16	145	3	18	116	110	5	2.89
125	139.7	133	240/235	200	18	8	M16	175	3	20	141.5	135	5	3.94
150	168.3	159	265/260	225	18	8	M16	200	3	20	170.5	161	5	4.47
175		194	290	255	18	8	M16	230	3	22		196	6	5.54
200	219.1	219	320/315	280	18	8	M16	255	3	22	221.5	222	7	6.07
225		245	340	305	18	8	M16	280	3	22		248	8	6.60
250	273	273	375/370	335	18	12	M16	310	3	24	276.5	276	9	8.03
300	323.9	325	440/435	395	23	12	M20	362	4	24	327.5	328	9	10.30
350	355.6	377	490/485	445	23	12	M20	415	4	26	359.5	380	10	12.59
400	406.4	426	540/535	495	23	16	M20	462	4	28	411	430	10	15.20
450	457	480	595/590	550	23	16	M20	518	4	28	462	484	10	17.59
500	508	530	645/640	600	23	20/16	M20	568	4	30	513.5	534	10	20.67注意
600	610	630	755	705	26/25	20	M24/M22	670	5	30	616.5	634	10	26.57
700	711	720	860	810	26/25	24	M24/M22	755	5	32	715	724	10	37.10
800	813	820	975	920	30	24	M27	880	5	32	817	824	10	46.20
900	914	920	1075	1020	30	24	M27	980	5	34	918	924	10	55.10
1000	1016	1020	1175	1120	30	28	M27	1080	5	36	1020	1024	10	64.36
1200	1219	1220	1405/1400	1340	34	32	M30	1295	5	30	1223	1224	12	73参考
1300		1320	1520	1450	34	32	M30	1405	5	30		1324	12	80参考
1400	1422	1420	1630/1620	1560	36/34	36	M33/M30	1510	5	34	1426	1424	14	105参考
1500		1520	1720	1660	34	36	M30	1610	5	34		1524	14	115参考
1600	1626	1620	1830/1820	1760	36/34	40	M33/M30	1710	5	36	1630	1624	16	125参考
1750			1995	1920	41	44	M36	1860	5	36			16	155参考
1800	1829	1820	2045	1970	41	44	M36	1910	5	38	1833	1824	17	170参考
2000	2032	2020	2265	2180	42/48	48	M39/M42	2110	5	38	2036	2024	19	210参考
2200			2475	2390	48	52	M42	2330	6	40			20	240参考
2400			2685	2600	48	56	M42	2540	6	42			22	300参考

法兰参数对照表

Flange parameters comparison table

表2 PN1.0MPa (10压力) 板式平焊钢制管法兰 mm

公称 口径 DN	管子外径 A1		连接尺寸					密封面尺寸		法兰 厚度 C	法兰内径 B1		坡口 宽度 b	法兰理论 重量系列 Z kg
	国际 A管	国内 B管	法兰外径 系列1/系列2 D	螺栓孔 中心圆 直径K	螺栓孔直径 系列1/系列2 L	螺栓、螺柱					A	B		
						数量n	螺纹Th. 系列1/系列2	d	f					
10	17.2	14	90	60	14	4	M12	40	2	12	18	15	3	0.46
15	21.3	18	95	65	14	4	M12	45	2	12	22	19	3	0.51
20	26.9	25	105	75	14	4	M12	55	2	14	27.5	26	3	0.75
25	33.7	32	115	85	14	4	M12	65	2	14	34.5	33	4	0.89
32	42.4	38	140/135	100	18	4	M16	78	2	16	43.5	39	4	1.40
40	48.3	45	150/145	110	18	4	M16	85	3	18	49.5	46	4	1.71
50	60.3	57	165/160	125	18	4	M16	100	3	18	61.5	59	4	2.09
65	76.1	76	185/180	145	18	4	M16	120	3	20	77.5	78	5	2.84
80	88.9	89	200/195	160	18	3/4	M16	135	3	20	90.5	91	5	3.24注意
100	114.3	108	220/215	180	18	8	M16	155	3	22	116	110	5	4.01
125	139.7	133	250/245	210	18	8	M16	185	3	24	141.5	135	5	5.46
150	168.3	159	285/280	240	23	8	M20	210	3	24	170.5	161	5	6.67
175		194	310	270	23	8	M20	240	3	24		196	6	7.44
200	219.1	219	340/335	295	23	8	M20	265	3	24	221.5	222	7	8.24
225		245	365	325	23	8	M20	295	3	24		248	8	9.30
250	273	273	395/390	350	23	12	M20	320	3	26	276.5	276	9	10.7
300	323.9	325	445/440	400	23	12	M20	363	4	28	327.5	328	9	12.9
350	355.6	377	505/500	460	23	16	M20	423	4	28	359.5	380	10	15.9
400	406.4	426	565	515	26/25	16	M24/M22	482	4	30	411	430	10	21.8
450	457	480	615	565	26/25	20	M24/M22	532	4	30	462	484	10	24.4
500	508	530	670	620	26/25	20	M24/M22	585	4	32	513.5	534	10	27.7
600	610	630	780	725	30	20	M27	685	5	36	616.5	634	10	39.4
700	711	720	895	840	30	24	M27	800	5	36	715	724	10	53
800	813	820	1015/1010	950	34	24	M30	905	5	38	817	824	10	67
900	914	920	1115/1110	1050	34	28	M30	1005	5	38	918	924	10	76参考
1000	1016	1020	1230/1220	1160	36/34	28	M33/M30	1115	5	38	1020	1024	10	90参考
1200	1219	1220	1340	1270	36	28	M33	1222	5	40		1124	10	125参考
1300		1320	1455/1450	1380	39/41	32	M36	1325	5	44	1223	1224	12	143参考
1400	1422	1420	1575	1490	41	32	M36	1420	5	46		1324	12	180参考
1500		1520	1575	1590	42/48	36	M39/M42	1525	5	48	1426	1424	14	195参考
1600	1626	1620	1785	1700	48	36	M42	1640	5	50		1524	14	225参考
1750			1915	1820	48/54	40	M45/M48	1750	5	52	1630	1624	16	275参考
1800	1829	1820	2065	1970	54	44	M48	1900	5	54			16	310参考
2000	2032	2020	2115	2020	48/54	44	M45/M48	1950	5	56	1833	1824	17	340参考
2200			2325	2230	48/54	48	M45/M48	2160	5	60	2036	2024	18	420参考
2400			2550	2440	56	52	M52	2370	6	80			20	660参考

法兰参数对照表

Flange parameters comparison table

表3 PN1.6MPa (16压力) 板式平焊钢制管法兰 mm

公称 口径 DN	管子外径 A1		连接尺寸					密封面尺寸		法兰 厚度 C	法兰内径 B1		坡口 宽度 b	法兰理论 重量系列 Z kg
	国际 A管	国内 B管	法兰外径 系列1/系列2 D	螺栓孔 中心圆 直径K	螺栓孔直径 系列1/系列2 L	螺栓、螺柱					A	B		
						数量n	螺纹Th. 系列1/系列2	d	f					
10	17.2	14	90	60	14	4	M12	40	2	14	18	15	3	0.55
15	21.3	18	95	65	14	4	M12	45	2	14	22	19	3	0.71
20	26.9	25	105	75	14	4	M12	55	2	16	27.5	26	3	0.87
25	33.7	32	115	85	14	4	M12	65	2	18	34.5	33	4	1.18
32	42.4	38	140/135	100	18	4	M16	78	2	18	43.5	39	4	1.60
40	48.3	45	150/145	110	18	4	M16	85	3	20	49.5	46	4	2.00
50	60.3	57	165/160	125	18	4	M16	100	3	22	61.5	59	4	2.61
65	76.1	76	185/180	145	18	4	M16	120	3	24	77.5	78	5	3.45
80	88.9	89	200/195	160	18	8	M16	135	3	24	90.5	91	5	3.71
100	114.3	108	220/215	180	18	8	M16	155	3	24	116	110	5	4.80
125	139.7	133	250/245	210	18	8	M16	185	3	28	141.5	135	5	6.47
150	168.3	159	285/280	240	23	8	M20	210	3	28	170.5	161	5	7.92
175		194	310	270	23	8	M20	240	3	28		196	6	8.81
200	219.1	219	340/335	295	23	12	M20	265	3	30	221.5	222	7	10.10
225		245	365	325	23	12	M20	295	3	30		248	8	11.20
250	273	273	405	355	26/25	12	M24/M22	320	3	32	276.5	276	9	15.70
300	323.9	325	460	410	26/25	12	M24/M22	375	4	32	327.5	328	9	18.10
350	355.6	377	520	470	26/25	16	M24/M22	436	4	34	359.5	380	10	23.30
400	406.4	426	580	525	30	16	M27	485	4	38	411	430	10	31.00
450	457	480	640	585	30	20	M27	515	4	42	462	484	10	40.20
500	508	530	715/705	650	34	20	M30	608	4	48	513.5	534	10	55.20
600	610	630	840	770	36/41	20	M33/M36	718	5	50	616.5	634	10	80.80
700	711	720	910	840	36/41	24	M33/M36	788	5	50	715	724	10	106.0
800	813	820	1025/1020	950	39/41	24	M36	898	5	52	817	824	10	130.5
900	914	920	1125/1120	1050	39/41	28	M36	998	5	44	918	924	10	91参考
1000	1016	1020	1255	1170	42/48	28	M39/M42	1110	5	46	1020	1024	10	127参考
1100		1120	1370	1280	42	28	M39	1222	5	50		1124	10	160参考
1200	1219	1220	1485	1390	48/54	32	M45/M48	1325	5	52	1223	1224	12	186参考
1300		1320	1585	1490	54	32	M48	1425	5	54		1324	12	215参考
1400	1422	1420	1685	1590	48/54	36	M48/M45	1525	5	58	1426	1424	14	245参考
1500		1520	1820	1710	54	36	M48	1640	5	60		1524	14	320参考
1600	1626	1620	1930	1820	55/58	40	M52	1750	5	64	1630	1624	16	360参考
1750			2080	1970	58	44	M52	1900	5	66			16	400参考
1800	1829	1820	2130	2020	55/58	44	M52	1950	5	68	1833	1824	17	430参考
2000	2032	2020	2345	2230	60	48	M56	2150	5	70	2036	2024	18	515参考

※系列1国家标准GB/T9119-2000/系列2机械行业标准JB/T81-94

法兰参数对照表

Flange parameters comparison table

表4 PN2.5MPa (25压力) 板式平焊钢制管法兰 mm

公称 口径 DN	管子外径 A1		连接尺寸					密封面尺寸		法兰 厚度 C	法兰内径 B1		坡口 宽度 b	法兰理论 重量系列 Z kg
	国际 A管	国内 B管	法兰外径 系列1/系列2 D	螺栓孔 中心圆 直径K	螺栓孔直径 系列1/系列2 L	螺栓、螺柱					A	B		
						数量n	螺纹Th. 系列1/系列2	d	f					
10	17.2	14	90	60	14	4	M12	40	2	16	18	15	3	0.64
15	21.3	18	95	65	14	4	M12	45	2	16	22	19	3	0.80
20	26.9	25	105	75	14	4	M12	55	2	18	27.5	26	3	0.99
25	33.7	32	115	85	14	4	M12	65	2	18	34.5	33	4	1.18
32	42.4	38	140/135	100	18	4	M16	78	2	20	43.5	39	4	1.96
40	48.3	45	150/145	110	18	4	M16	85	3	22	49.5	46	4	2.60
50	60.3	57	165/160	125	18	4	M16	100	3	24	61.5	59	4	2.71
65	76.1	76	185/180	145	18	8	M16	120	3	24	77.5	78	5	3.22
80	88.9	89	200/195	160	18	8	M16	135	3	26	90.5	91	5	4.06
100	114.3	108	235/230	190	23	8	M20	160	3	28	116	110	5	6.00
125	139.7	133	270	220	26/25	8	M24/M22	188	3	30	141.5	135	5	8.26
150	168.3	159	300	250	26/25	8	M24/M22	218	3	30	170.5	161	5	10.40
175		194	330	280	26/25	12	M24/M22	248	3	32		196	6	11.90
200	219.1	219	360	310	26/25	12	M24/M22	278	3	32	221.5	222	7	14.50
225		245	395	340	30	12	M27	302	3	34		248	8	17.00
250	273	273	425	370	30	12	M27	332	3	34	276.5	276	9	18.90
300	323.9	325	485	430	30	16	M27	390	4	36	327.5	328	9	26.80
350	355.6	377	555/550	490	34	16	M30	448	4	42	359.5	380	10	34.35
400	406.4	426	620/610	550	36/34	16	M33/M30	505	4	44	411	430	10	44.90
450	457	480	670/660	600	36/34	20	M33/M30	555	4	48	462	484	10	51.92
500	508	530	730	660	36/41	20	M33/M36	610	4	52	513.5	534	10	67.30
600	610	630	845/840	770	41	20	M36	718	5	56	616.5	634	10	95.20
700	711	720	960/955	875	42/48	24	M39/M42	815	5	60	715	724	10	116
800	813	820	1085/1070	990	48	24	M45/M42	930	5	64	817	824	10	150.2
900	914	920	1185/1180	1090	48/54	28	M45/M48	1025	5	58	918	924	10	160参考
1000	1016	1020	1320/1305	1210	55/58	28	M52	1140	5	62	1020	1024	10	210参考
1100		1124	1425	1315	55	28	M52	1245	5	66		1124	10	260参考
1200	1219	1220	1530/1525	1420	55/58	32	M52	1350	5	70	1223	1224	12	300参考
1300		1320	1640	1530	65	32	M56	1450	5	74		1324	12	355参考
1400	1422	1420	1755/1750	1640	60/65	36	M56	1560	5	76	1426	1424	14	450参考
1500		1520	1865	1750	60	36	M56	1670	5	80		1524	14	530参考
1600	1626	1620	1975	1860	60	40	M56	1780	5	84	1630	1624	16	570参考
1800	1829	1820	2195	2070	68	44	M64	1985	5	90	1833	1824	17	700参考
2000	2032	2020	2425	2300	68	48	M64	2210	5	96	2036	2024	18	900参考

※系列1国家标准GB/T9119-2000/系列2机械行业标准JB/T81-94

法兰参数对照表

Flange parameters comparison table

表5 PN4.0MPa (40压力) 凹凸面对焊钢制管法兰 mm

公称 口径 DN	管子外径 A1		连接尺寸					密封面尺寸					法兰颈				法兰理论 重量系列 2 kg				
	国际 A管	国内 B管	法兰外径 系列1/ 系列2 D	螺栓 孔中 心圆 直径 K	螺栓孔 直径 系列1/ 系列2 L	螺栓、螺柱		d	X凸面 系列1/ 系列2	Y凹面 系列1/ 系列2	f	f1 f2	法兰 厚度 C	法兰 内径 B	法兰 高度 H	颈部 直径 Nmax			法兰 焊端 壁厚 S	直边 段 H1	圆角 半径 R
						数量 n	螺柱 Th. 系列1/ 系列2										A型	B型			
10	17.2	14	90	60	14	4	M12	40	34	35	2	4	16	8	35	26	2.3	6	3	0.77	0.67
15	21.3	18	95	65	14	4	M12	45	39	40	2	4	16	12	35	30	3.2	6	3	0.87	0.77
20	26.9	25	105	75	14	4	M12	55	50	51	2	4	16	18	36	38	3.2	6	4	1.09	0.97
25	33.7	32	115	85	14	4	M12	65	57	58	2	4	16	25	38	45	3.2	6	4	1.31	1.18
32	42.4	38	140/135	100	18	4	M16	78	65	66	2	4	18	31	45	56	3.6	6	5	2.17	1.98
40	48.3	45	150/145	110	18	4	M16	85	75	76	3	4	18	38	48	64	3.6	7	5	2.51	2.14
50	60.3	57	165/160	125	18	4	M16	100	87	88	3	4	20	48	48	76	4	8	5	3.34	2.92
65	76.1	76	185/180	145	18	4	M16	120	109	110	3	4	22	66	52	96	5	10	6	4.34	3.85
80	88.9	89	200/195	160	18	8	M16	135	120	121	3	4	24	78	58	112	5.6	12	6	5.52	5.03
100	114.3	108	235/230	190	23	8	M20	160	149	150	3	4.5	26	96	68	138	6.3	12	6	8.39	7.71
125	139.7	133	270	220	26/25	8	M24/M22	188	175	176	3	4.5	28	120	68	160	6.3	12	6	11.06	10.27
150	168.3	159	300	250	26/25	8	M24/M22	218	203	204	3	4.5	30	145	72	186	7.1	12	6	14.16	13.30
(175)		194	350	295	30	8	M27	258	233	234	3	4.5	36	177	88	226	7.1	12	6	21.80	20.97
200	219.1	219	375	320	30	12	M27	282	259	260	3	4.5	38	200	88	250	8	16	8	25.56	24.72
(225)		245	415	355	34	12	M30	315	286	287	3	4.5	40	226	98	280	8	16	8	32.48	31.60
250	273	273	450/445	385	34	12	M30	345	312	313	3	4.5	42	252	102	310	10	18	10	39.87	39.00
300	323.9	325	515/510	450	34	12	M30	408	363	364	4	4.5	46	301	116	368	10	18	10	55.97	53.21
350	355.6	377	580/570	510	36/34	16	M33/M30	465	421	422	4	5	52	351	120	418	11	20	10	75.30	72.29
400	406.4	426	660/655	585	41	16	M36	535	473	474	4	5	58	398	142	480	12.5	20	10	112.02	108.44
450	457	480	685/680	610	41	20	M36	560	523	524	4	5	60	448	146	530	14.2	20	12	112.82	109.70
500	508	530	755	670	42/48	20	M39/M42	612	575	576	4	5	62	495	156	580	16	20	12	142.70	138.60
600	610	630	890	795	48/54	20	M45/M48	730	675/677	676/678	5	6	62	595	176	700	17.5	20	20	167	160参考
700	711	720	995	900	48/54	24	M45/M48	835	777/767	778/768	5	6	68	680	200	780	19	20	20	275	265参考
800	813	820	1140/1135	1030	58	24	M52	960	882/875	883/876	5	6	76	780	220	910	20	20	22	410	400参考

※系列1国家标准GB/T9119-2000/系列2机械行业标准JB/T81-94

法兰参数对照表

Flange parameters comparison table

表6 PN6.3MPa (64压力) 凹凸面对焊钢制管法兰 mm

公称 口径 DN	管子外径 A1		连接尺寸					密封面尺寸					法兰颈				法兰理论 重量系列 2 kg				
	国际 A管	国内 B管	法兰外径 系列1/ 系列2 D	螺栓 孔中 心圆 直径 K	螺栓孔 直径 系列1/ 系列2 L	螺栓、螺柱		d	X凸面 系列1/ 系列2	Y凹面 系列1/ 系列2	f	f1 f2	法兰 厚度 C	法兰 内径 B	法兰 高度 H	颈部 直径 Nmax			法兰 焊端 壁厚 S	直边 段 H1	圆角 半径 R
						数量 n	螺柱 Th. 系列1/ 系列2										A型	B型			
10	17.2	14	100	70	14	4	M12	50	34	35	2	4	18	8	48	34	3	6	3	1.12	1.02
15	21.3	18	105	75	14	4	M12	55	39	40	2	4	18	12	48	38	3.2	6	3	1.25	1.14
20	26.9	25	130/125	90	18	4	M16	68	50	51	2	4	20	18	56	48	3.6	6	4	2.12	1.95
25	33.7	32	140/135	100	18	4	M16	78	57	58	2	4	22	25	58	52	3.6	8	4	2.64	2.46
32	42.4	38	155/150	110	23	4	M20	82	65	66	2	4	24	31	62	64	3.6	8	5	3.50	3.28
40	48.3	45	170/165	125	23	4	M20	95	75	76	3	4	24	37	68	74	4	10	5	4.35	3.91
50	60.3	57	180/175	135	23	4	M20	105	87	88	3	4	26	47	70	86	5	10	5	5.29	4.80
65	76.1	76	205/200	150	23	8	M20	130	109	110	3	4	28	64	75	106	6	12	6	7.00	6.43
80	88.9	89	215/210	170	23	8	M20	140	120	121	3	4	30	77	75	120	6	12	6	8.07	7.50
100	114.3	108	250	200	26/25	8	M24/M22	168	149	150	3	4.5	32	94	80	140	7	12	6	11.51	10.80
125	139.7	133	295	240	30	8	M27	202	175	176	3	4.5	36	118	98	172	7.5	12	6	18.02	17.09
150	168.3	159	345/340	280	34	8	M30	240	203	204	3	4.5	38	142	108	206	8.5	12	8	26.45	25.29
(175)		194	375/370	310	34	12	M30	270	233	234	3	4.5	42	174	110	232	8.5	12	8	30.63	29.61
200	219.1	219	415/405	345	36/34	12	M33/M30	300	259	260	3	4.5	44	198	116	264	10.5	16	8	39.63	38.51
(225)		245	430	370	36/34	12	M33/M30	325	286	287	3	4.5	46	222	120	290	10.5	16	8	43.34	42.32
250	273	273	470	400	36/41	12	M33/M36	352	312	313	3	4.5	48	246	122	316	13.5	18	10	53.64	52.47
300	323.9	325	530	460	36/41	16	M33/M36	412	363	364	4	4.5	54	294	136	370	15.5	18	10	73.10	69.97
350	355.6	377	600/595	525	41	16	M36	475	421	422	4	5	60	342	154	430	17.5	20	10	103.50	100.10
400	406.4	426	670	585	42/48	16	M39/M42	525	473	474	4	5	66	386	170	484	20	20	10	143.30	138.90
450	457	480	715	630	48	20	M42	570	523	524	4	5	70	440	186	540	22.5	22	15	160	155参考
500	508	530	800	705	48/54	20	M45	640	575	576	4	5	70	485	200	595	22.5	22	18	215	210参考
600	610	630	930	820	58	20	M52	750	675/677	676/678	5	6	76	585	220	710	25	22	18	320	310参考
700	711	720	1045	935	58	24	M52	865	777/767	778/768	5	6	84	670	240	800	25	24	18	450	435参考
800	813	820	1165	1050	62	24	M56	980	882/875	883/876	5	6	90	765	260	925	25	24	18	540	525参考

※系列1国家标准GB/T9119-2000/系列2机械行业标准JB/T81-94

法兰参数对照表

Flange parameters comparison table

表7 PN10.0MPa (100压力) 凹凸面对焊钢制管法兰 mm

公称 口径 DN	管子外径 A1		连接尺寸					密封面尺寸					法兰颈				法兰理论 重量系列 2 kg				
	国际 A管	国内 B管	法兰外径 系列1/ 系列2 D	螺栓 孔中 心圆 直径 K	螺栓孔 直径 系列1/ 系列2 L	螺栓、螺柱 数量 n	螺栓 Th 系列1/ 系列2	d	X凸面 系列1/ 系列2	Y凹面 系列1/ 系列2	f	f1 f2	法兰 厚度 C	法兰 内径 B	法兰 高度 H	颈部 直径 Nmax	法兰 焊端 壁厚 S	直边 段 H1	圆角 半径 R	A型	B型
10	17.2	14	100	70	14	4	M12	50	34	35	2	4	18	8	45	34	3	6	3	1.12	1.01
15	21.3	18	105	75	14	4	M12	55	39	40	2	4	20	12	48	38	3.2	6	3	1.37	1.26
20	26.9	25	130/125	90	18	4	M16	68	50	51	2	4	22	18	56	48	3.6	6	4	2.30	2.13
25	33.7	32	140/125	100	18	4	M16	78	57	58	2	4	24	25	58	52	3.6	8	4	2.86	2.67
32	42.4	38	155/150	110	23	4	M20	82	65	66	2	4	24	31	62	64	3.6	8	5	3.50	3.28
40	48.3	45	170/165	125	23	4	M20	95	75	76	3	4	26	37	70	76	4	10	5	4.72	4.28
50	60.3	57	195	145	26/25	4	M24/M22	112	87	88	3	4	28	45	72	86	6	10	5	6.58	6.02
65	76.1	76	220	170	26/25	8	M24/M22	138	109	110	3	4	32	62	84	110	7	12	6	9.20	8.60
80	88.9	89	230	180	26/25	8	M24/M22	148	120	121	3	4	34	75	90	124	7	12	6	10.61	9.97
100	114.3	108	265	210	30	8	M27	172	149	150	3	4.5	38	92	100	146	8	12	6	15.54	14.70
125	139.7	133	315/310	250	34	8	M30	210	175	176	3	4.5	42	112	115	180	10.5	12	6	25.10	24.00
150	168.3	159	355/350	290	34	12	M30	250	203	204	3	4.5	46	136	130	214	11.5	12	8	34.43	33.26
(175)		194	385/380	320	34	12	M30	280	233	234	3	4.5	48	166	135	246	11.5	16	10	41.60	40.47
200	219.1	219	430	360	36/41	12	M33/M36	312	259	260	3	4.5	54	190	145	276	14.5	16	10	57.14	55.80
(225)		245	470	400	41	12	M36	352	286	287	3	4.5	56	212	165	312	14.5	16	10	73.30	71.90
250	273	273	505/500	430	41	12	M36	382	312	313	3	4.5	60	236	170	340	18.5	18	10	89.30	87.90
300	323.9	325	585	500	42/48	16	M39/M42	442	363	364	4	4.5	70	284	195	400	20.5	18	12	137.45	130.10
350	355.6	377	665	560	48/54	16	M45/M48	498	421	422	4	5	76	332	210	460	22.5	20	12	186.00	175.20
400	406.4	426	715	620	48/54	16	M45/M48	558	473	474	4	5	80	376	220	510	25	20	12	223.50	218.50
450	457	480	770	675	58	20	M52	615	523	524	4	5	84	430	235	570	25	20	18	280	270参考
500	508	530	870	760	58	20	M52	690	575	576	4	5	90	465	245	600	30	22	18	350	335参考
600	610	630	990	875	58	24	M52	800	675/677	676/678	5	6	95	570	265	700	30	22	18	460	445参考

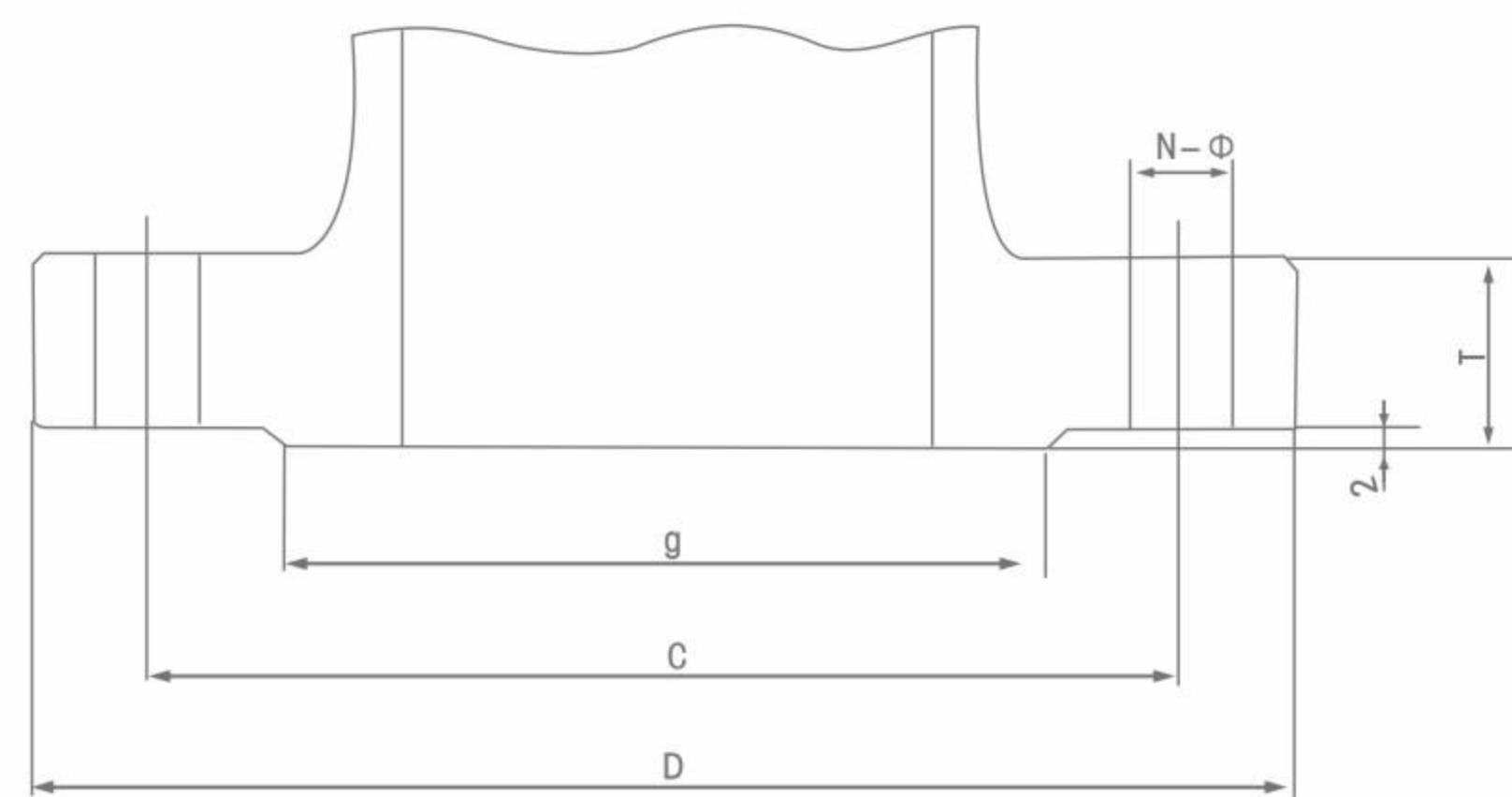

GB/T PN16 / PN40(RF)steel

※系列1国家标准GB/T9119-2000/系列2机械行业标准JB/T81-94

法兰参数对照表

Flange parameters comparison table

表8 PN2.0MPa (Class 150) 美标带颈平焊钢制管法兰 mm

公称 口径 NPS (in)	DN	钢管 外径 A	连接尺寸					密封面尺寸		法兰 厚度 C	法兰 内径 B	法兰颈 N	法兰 高度 H	理论 重量 kg
			法兰 外径 D	螺栓孔 中心圆 直径K	螺栓孔 直径 L	螺栓孔 数量n	螺纹 Th.	突面d	台高f1					
1/2	15	21.3	89	60.5	16	4	M14	35	1.6	11.5	22	30	16	0.41
3/4	20	26.9	98	70	16	4	M14	43	1.6	13	27.5	38	16	0.58
1	25	33.7	108	79.5	16	4	M14	51	1.6	14.5	34.5	49	17	0.80
1 1/4	32	42.4	117	89	16	4	M14	63.5	1.6	16	43.5	59	21	1.07
1 1/2	40	48.3	127	98.5	16	4	M14	73	1.6	17.5	49.5	65	22	1.37
2	50	60.3	152	120.5	18	4	M16	92	1.6	19.5	61.5	78	25	2.01
2 1/2	65	76.1	178	139.5	18	4	M16	105	1.6	22.5	77.5	90	29	3.32
3	80	88.9	190	152.5	18	4	M16	127	1.6	24	90.5	108	30	3.83
4	100	114.3	229	190.5	18	8	M16	157.5	1.6	24	116	135	33	5.40
5	125	139.7	254	216	22	8	M20	186	1.6	24	141.5	164	36	6.26
6	150	168.3	274	241.5	22	8	M20	216	1.6	25.5	170.5	192	40	7.50
8	200	219.1	343	298.5	22	8	M20	270	1.6	29	221.5	246	44	12.3
10	250	273	406	362	26	12	M24	324	1.6	30.5	276.5	305	49	16.2
12	300	323.9	483	432	26	12	M24	381	1.6	32	327.5	365	56	26.5
14	350	355.6	533	476	29.5	12	M27	413	1.6	35	359.5	400	57	34.5
16	400	406.4	597	540	29.5	16	M27	470	1.6	37	411	457	64	45.5
18	450	457	635	578	32.5	16	M30	533.5	1.6	40	462	505	68	48.5
20	500	508	698	635	32.5	20	M30	584	1.6	43	513.5	559	73	61.8
24	600	610	813	749.5	35.5	20	M33	692	1.6	48	616.5	664	83	87.7

表9 PN5.0MPa (Class 300) 美标带颈平焊钢制管法兰 mm

公称 口径 NPS (in)	DN	钢管 外径 A	连接尺寸					密封面尺寸		法兰 厚度 C	法兰 内径 B	法兰颈 N	法兰 高度 H	理论 重量 kg
			法兰 外径 D	螺栓孔 中心圆 直径K	螺栓孔 直径 L	螺栓孔 数量n	螺纹 Th.	突面d	台高f1					
1/2	15	21.3	89	66.5	16	4	M14	35	1.6	14.5	22	38	22	0.63
3/4	20	26.9	117	82.5	18	4	M16	43	1.6	16	27.5	48	25	1.16
1	25	33.7	124	89	18	4	M16	51	1.6	17.5	34.5	54	27	1.37
1 1/4	32	42.4	133	98.5	18	4	M16	63.5	1.6	19.5	43.5	64	27	
1 1/2	40	48.3	156	114.5	22	4	M20	73	1.6	21	49.5	70	30	
2	50	60.3	165	127	18	8	M16	92	1.6	22.5	61.5	84	33	
2 1/2	65	76.1	190	149	22	8	M20	105	1.6	25.5	77.5	100	38	
3	80	88.9	210	168.5	22	8	M20	127	1.6	29	90.5	118	43	
4	100	114.3	254	200	22	8	M20	157.5	1.6	32	116	146	48	
5	125	139.7	279	235	22	8	M20	186	1.6	35	141.5	178	51	
6	150	168.3	318	270	22	12	M20	216	1.6	37	170.5	206	52	
8	200	219.1	381	330	26	12	M24	270	1.6	41.5	221.5	260	62	
10	250	273	444	387.5	29.5	16	M27	324	1.6	48	276.5	321	67	
12	300	323.9	521	451	32.5	16	M30	381	1.6	51	327.5	375	73	
14	350	355.6	584	514.5	32.5	20	M30	413	1.6	54	359.5	426	76	
16	400	406.4	648	571.5	35.5	20	M33	470	1.6	57.5	411	483	83	
18	450	457	711	628.5	35.5	24	M33	533.5	1.6	60.5	462	533	89	
20	500	508	775	686	35.5	24	M33	584	1.6	63.5	513.5	587	95	
24	600	610	915	813	42	24	M39×3	692	1.6	70	616.5	702	104	

※系列1国家标准GB/T9119-2000/系列2机械行业标准JB/T81-94

法兰参数对照表

Flange parameters comparison table

表10 PN11.0MPa (Class 600) 美标带颈平焊制管法兰 mm

公称 口径 NPS (in)	DN	钢管 外径 A	连接尺寸					密封面尺寸		法兰 厚度 C	法兰 内径 B	法兰 颈 N	法兰 高度 H	理论 重量 kg
			法兰 外径 D	螺栓孔 中心圆 直径K	螺栓孔 直径 L	螺栓孔 数量n	螺纹 Th.	突面d	台高f1					
1/2	15	21.3	95	66.5	16	4	M14	35	6.4	14.5	14	38	52	1.35
3/4	20	26.9	118	82.5	18	4	M16	43	6.4	16	18.5	48	57	1.59
1	25	33.7	124	89	18	4	M16	51	6.4	17.5	24.5	54	62	1.82
1 1/4	32	42.4	133	98.5	18	4	M16	63.5	6.4	21	32	64	67	2.50
1 1/2	40	48.3	156	114.5	22	4	M20	73	6.4	22.5	38	70	70	3.63
2	50	60.3	165	127	18	8	M16	92	6.4	25.5	49	84	73	4.54
2 1/2	65	76.1	190	149	22	8	M20	105	6.4	29	61.5	100	79	6.36
3	80	88.9	210	168.5	22	8	M20	127	6.4	32	72.5	117	83	8.17
4	100	114.3	273	216	26	8	M24	157.5	6.4	38.5	96.5	152	102	16.8
5	125	139.7	330	267	29.5	8	M27	186	6.4	44.5	119.5	189	114	30.9
6	150	168.3	356	292	29.5	12	M27	216	6.4	48	146	222	117	33.1
8	200	219.1	419	349	32.5	12	M30	270	6.4	55.5	187	273	133	50.9
10	250	273	508	432	35.5	16	M33	324	6.4	63.5	238	343	152	85.8
12	300	323.9	560	489	35.5	20	M33	381	6.4	67	279.5	400	156	102.6
14	350	355.6	605	527	39	20	M36×3	413	6.4	70	305.5	432	165	157.5
16	400	406.4	685	603	42	20	M39×3	470	6.4	76.5	350	495	178	218.4
18	450	457	745	654	45	20	M42×3	533.5	6.4	83	397	546	184	252.0
20	500	508	815	724	45	24	M42×3	584	6.4	89	444	610	190	313.3
22	550	559	870	778	48	24	M45×3	641	6.4	95	487	665	197	376.5
24	600	610	940	838	51	24	M48×3	692	6.4	102	530	718	203	443.6

材质化学成分表

Chemical composition list of materials

材质化学成分表 Material chemical composition list

ASTM	化学成份%											抗拉屈服				硬度 布氏硬度 Hb, ≤	屈服强度 J, ≥
	C ≤	Mn ≤	P ≤	S ≤	Si ≤	Cr ≤	Mo ≤	Ni ≤	Cu ≤	V ≤	Nb ≤	收缩率 MPa, ≥	延伸率 MPa, ≥	收缩率 %, ≥	延伸率 %, ≥		
A105	0.35	0.60-1.05	0.035	0.040	0.10-0.35	0.30	0.12	0.4	0.40	0.08	0.02	485	250	30	30	187	
A182 F11	0.05-0.15	0.30-0.60	0.030	0.030	0.50-1.00	100-150	0.44-0.65					415	205	20	45	121-174	
A182 F22	0.05-0.15	0.30-0.60	0.040	0.040	0.5	200-250	0.87-1.13					415	205	20	35	170	
A182 F304	0.08	2.00	0.045	0.030	1.00	180-200		80-110				515	205	30	50		
A182 F304L	0.030	2.00	0.045	0.030	1.00	180-200		80-130				485	170	30	50		
A182 F316	0.08	2.00	0.045	0.030	1.00	160-180	200-300	100-140				515	205	30	50		
A182 F316L	0.030	2.00	0.045	0.030	1.00	160-180	200-300	100-150				485	170	30	50		
A182 F51	0.030	2.00	0.030	0.020	1.00	210-230	25-35	45-65				620	450	25	45		
A182 F6a	0.15	1.00	0.040	0.030	1.00	115-135		0.50				585	380	18	35	167-229	
A93 B7	0.37-0.49	0.65-1.10	0.035	0.040	0.15-0.35	0.75-1.20	0.15-0.25					860	720	16	50	321	
A193 B7M	0.37-0.49	0.65-1.10	0.035	0.040	0.15-0.35	0.75-1.20	0.15-0.25	80-110				680	550	18	50	235	
A193 B8	0.08	2.00	0.045	0.030	1.00	180-200		100-140		0.25-0.35		515	205	30	50	223	
193 B8M	0.08	2.00	0.045	0.030	1.00	160-180	200-300					515	205	30	50	223	
A193 B16	0.36-0.47	0.45-0.70	0.035	0.040	0.15-0.35	0.80-1.15	0.50-0.65					860	720	18	50	321	
A194 2H	≥0.40	1.00	0.040	0.050	0.04											248-352	
A194 2HM	≥0.40	1.00	0.040	0.050	0.04			80-110								159-237	
A194 8	0.08	2.00	0.045	0.030	1.00	180-200		100-140								126-300	
A194 BM	0.08	2.00	0.045	0.030	1.00	160-180	200-300									126-300	
A216 WCB	0.30	1.00	0.04	0.045	0.60	0.50	0.20	0.50	0.30	0.03		485-655	250	22	35		
A216 WCC	.025	1.20	0.04	0.045	0.60	0.50	0.2	0.50	0.30	0.03		485-655	275	22	35		
A217 C5	0.20	0.40-0.70	0.04	0.045	0.75	400-650	0.45-0.65	0.50	0.50			620-795	415	18	35		
A217 CA15	0.15	1.00	0.040	0.040	1.50	115-140	0.50	1.00				620-795	450	18	30		
A217 WC6	0.05-0.20	0.50-0.80	0.04	0.045	0.60	100-150	0.45-0.65	0.50	0.50			485-655	275	20	35		
A217 WC9	0.05-0.18	0.40-0.70	0.04	0.045	0.60	200-275	0.90-1.20		0.50			480	275	20	35		
A276 410	0.08-0.15	1.00	0.040	0.030	1.00	115-135							275	20	45		
A276 420	≥15	1.00	0.040	0.030	1.00	120-140						860				241	
A320 L7	0.38-0.048	0.75-1.00	0.035	0.040	0.15-0.35	0.80-1.10	0.15-0.25					690	725	16	50		Avg27min20
A320 L7M	0.38-0.048	0.75-1.00	0.035	0.040	0.15-0.35	0.80-1.10	0.15-0.25					515-690	550	18	50	235	Avg27min20
A336 F22	0.05-0.15	0.30-0.60	0.025	0.025	0.5	200-250	0.90-1.10					415-585	310	19	40		
A350 LF1	0.30	0.60-1.35	0.035	0.040	0.15-0.30	0.30	0.12	0.40	0.40	0.08	0.02	415-585	205	28	38		Avg18min14
A350 LF2	0.30	0.60-1.35	0.035	0.040	0.15-0.30	0.30	0.12	0.40	0.40	0.08	0.02	485-655	250	30	30		Avg20min16
A351 CF8	0.08	1.50	0.040	0.040	2.00	180-210	0.50	80-110				485	205	35.0			
A351 CF3	0.03	1.50	0.040	0.040	2.00	170-210	0.50	80-120				485	205	35.0			
A351 CF8M	0.08	1.50	0.040	0.040	1.50	180-210	200-300	90-120				485	205	30.0			
A351 CF3M	0.03	1.50	0.040	0.040	1.50	170-210	200-300	90-130				485	205	30.0			
A351 CF8C	0.08	1.50	0.040	0.040	2.00	180-210	0.50	90-120	3.0-4.0			485	205	30.0			
A351 CN7M	0.07	1.50	0.040	0.040	1.50	190-220	200-300	275-305				425	170	35			
A352 LC1	0.25	0.50-0.80	0.04	0.045	0.60		0.45-0.65					450-620	240	24	35		
A352 LC2	0.25	0.50-0.80	0.04	0.045	0.60			200-300				485-655	275	24	35		Avg18min14
A352 LC3	0.15	0.50-0.80	0.04	0.045	0.60			300-400				485-655	275	24	35		Avg20min16
A352 LCB	0.30	1.00	0.04	0.045	0.60	0.50	0.20	0.50	0.30	0.30		450-620	240	24	35		Avg20min16
A352 LCC	.025	1.20	0.04	0.045	0.60	0.50	0.20	0.50		0.30		485-655	275	22	35	139-202	Avg18min14
A439 D2	0.30	0.70-1.25	0.08		1.50-3.00	175-275		1800-2200				400	207	80			Avg20min16

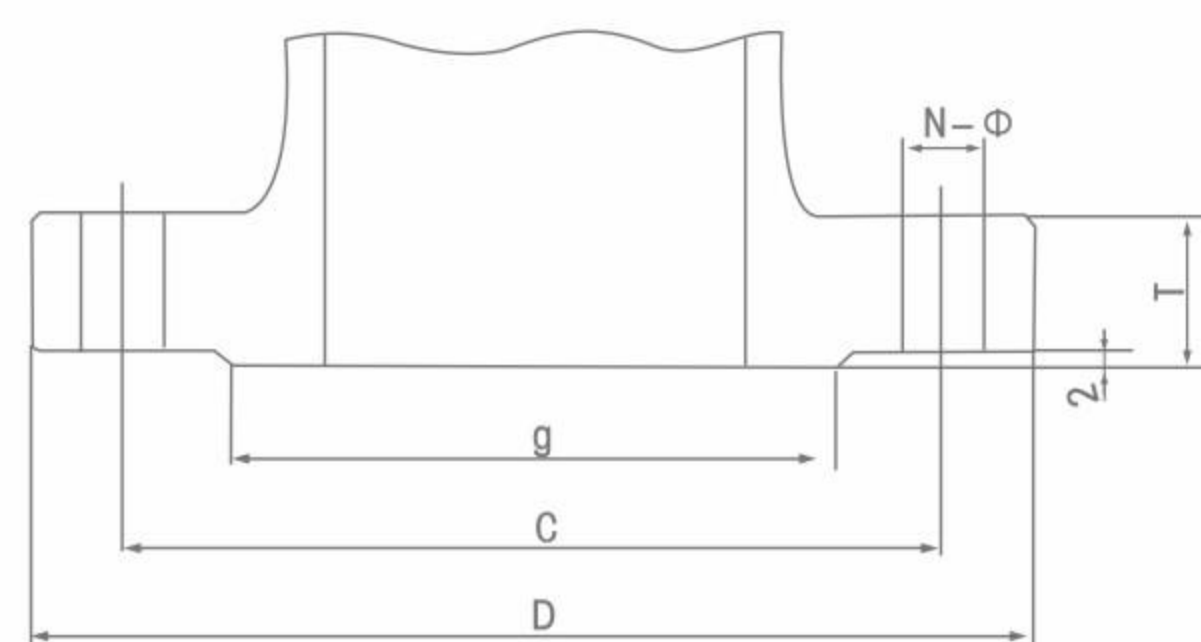

Class 150 / 300Lb (RF)Steel

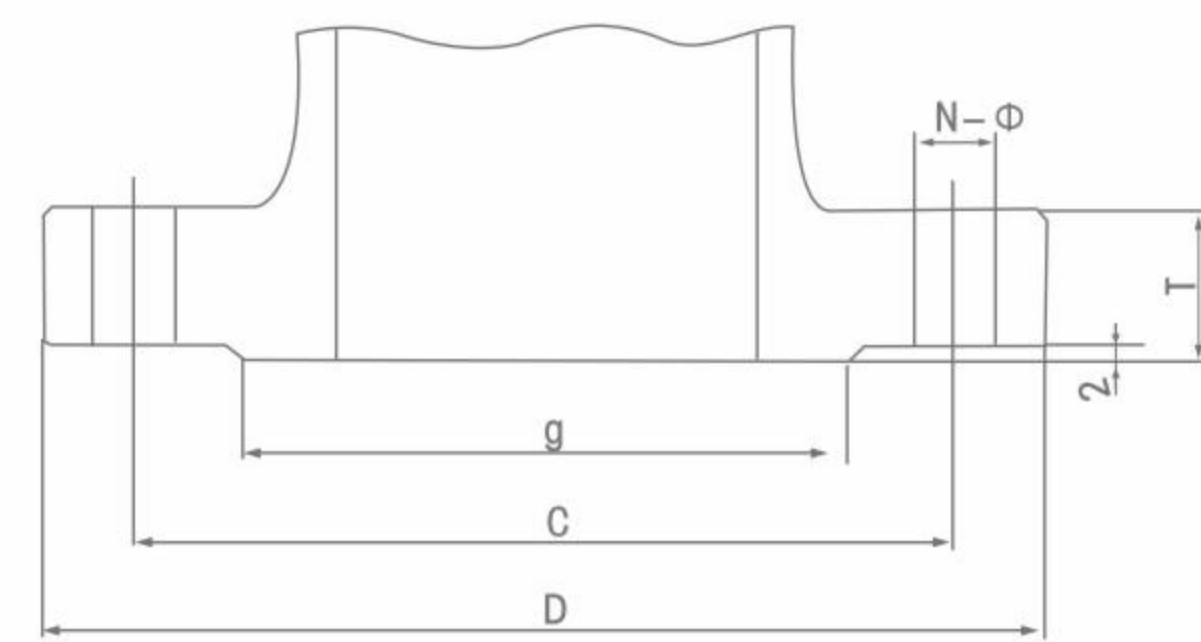

Class 600Lb (RF)Steel



浙江瑞通阀门有限公司
ZHEJIANG RUITONG VALVE CO.,LTD

售后服务和质量保证承诺

一、售前服务

做到技术与销售的无缝对接服务，让用户的每一次采购都有服务的体验。

- ① 进行采购前产品技术沟通和交流，主动给予建议。
- ② 在进行产品型号选择时考虑是否成本最低化，效率最大化。
- ③ 不能达到使用要求时，根据客户的特殊要求，安排设计师合理改善。

二、售中服务

尊重每位用户；给用户一份轻松，放心的整体价值服务。

- ① 进行性价比：比价格，比质量，比服务，反思是否有不做到位的地方。
- ② 在合作过程中，依照合同，保质保量准时交货，随时保持与用户联系。
- ③ 生产期间，相关技术人员可来我司进行产品监造和检验，同时，我司会提供该产品的结构图及详细文件资料，来做监造文件。
- ④ 使用定做的产品，可协商专业技术人员亲临现场指导。
- ⑤ 我公司在发货前以电话进行产品型号、规格、数量、件数的确认。

三、售后服务

完善的服务铸就完美的企业让客户无后顾之忧。

- ① 按合同要求提供产品的合格证、生产许可证、检验报告、安装说明书等。
- ② 顾客在验收产品过程中，如出现与合同要求不符时，我司接到顾客通知后两小时内给予处理。
- ③ 我司提供十二个月的产品质保期，时间从验收合格之日起计算。
- ④ 在正确安装和使用下，出现产品质量问题，本公司将负责到底。

四、包修包换承诺

- ① 在正常的储运、安装、保养、使用条件下，因产品的质量不能正常使用时，提供三保四包：保质、保量、保及时、包修、包换、包退、包损失。
- ② 在接到质量信息反馈时，将在48小时内提出处理意见及解决方案。
- ③ 可根据用户需求协商提供备品、备件和安装、调试、维修服务。

以上四点是我公司对售后服务的承诺。竭诚欢迎广大用户指导修正，请提出宝贵意见，参照改进。真诚希望我们之间合作愉快。



浙江瑞通阀门有限公司
ZHEJIANG RUITONG VALVE CO.,LTD

AFTER-SALES SERVICE QUALITY ASSURANCE COMMITMENT

1、Pre-sales service

Achieve the seamless connection between technology and sales, and let users have a service experience with every purchase.

- ① Conduct product technical communication and exchange before purchase, and offer suggestions actively.
- ② When selecting product models, consider whether to minimize costs and maximize efficiency.
- ③ If the use requirements cannot be met, the designer shall be arranged for reasonable improvement according to the special requirements of customers.

2、On-sale service

Respect every user; Give users a relaxed and assured overall value service.

- ① Compare performance with price: compare price, quality and service, and reflect on whether there is anything that is not done well.
- ② In the process of cooperation, according to the contract, deliver goods on time with quality and quantity guaranteed, and keep in touch with users at any time.
- ③ During production, relevant technical personnel can come to our company for product supervision and inspection. At the same time, our company will provide the structure diagram and detailed documents of the product to make supervision documents.
- ④ For the use of customized products, professional technicians can be consulted for on-site guidance.
- ⑤ Our company confirms the product model, specification, quantity and quantity by telephone before delivery.

3、After-sales service

Perfect service creates perfect enterprise, and customers have no worries.

- ① Provide product certificates, production licenses, inspection reports, installation instructions, etc. according to the contract requirements.
- ② In the process of customer acceptance, if there is any discrepancy with the contract requirements, our company will deal with it within two hours after receiving the customer's notice.
- ③ Our company provides a 12-month product warranty period from the date of acceptance.
- ④ Under the correct installation and use, the company will be responsible for the product quality problems.

4、Commitment to repair and replacement

- ① Under normal storage, transportation, installation, maintenance and use conditions, if the product cannot be used normally due to quality problems, three guarantees and four guarantees shall be provided: quality assurance, quantity assurance, timeliness assurance, repair assurance, replacement assurance, return assurance and loss assurance.
- ② When receiving the feedback of quality information, it will put forward handling suggestions and solutions within 48 hours.
- ③ Spare parts and installation, commissioning and maintenance services can be provided through negotiation according to user needs.

The above four points are our company's commitment to after-sales service. We sincerely welcome the majority of users to guide the correction. Please put forward your valuable suggestions for reference and improvement. We sincerely hope that our cooperation will be pleasant.